

NOTICE

- * Please make sure that you have all parts indicated and they are in good condition before you begin assembly of this item. Refer to part list and hardware list below for guidance.
- * This item should be assembled on a soft surface to prevent scratching the finish during assembly.
- * This item may require periodic tightening.
- * If you are having difficulty, our friendly Customer Care team is always here to help. Please email customersupport@safavieh.com





PREPARATION

- * Before beginning assembly of product, make sure all parts are present. Compare parts with part contents list and hardware contents list.
- * If any part is missing or damaged, do not attempt to assemble the product.
- * Estimated Assembly Time: 15 minutes.
- * This item may require periodic tightening.
- * Tools Required for Assembly (included): Allen Key

CARE AND MAINTENANCE

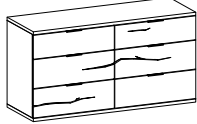
Always use felt pads under all articles to prevent discoloration or softening of the lacquer. Plastic and rubber bases on items can discolor wood. Wipe up spills immediately and avoid common hazards such as hot dishes, harsh solvents and abrasives. Cleaning should be done with a soft lint free cotton cloth dampened with water or furniture polish. On highly used surfaces we recommend applying a quality paste wax which should be used on a regular basis to provide additional protection from scratches and spills. How often you apply the wax depend on how much wear the furniture receives.

Part List and Hardware List

PIECE	DESCRIPTION	PICTURE	QUANTITY
A	6 Drawer Wood Dresser		1x
HW1	Metal Leg		4x
HW2	Allen Bolt: M6 x 1 x 20 mm		16x
HW3	Split Lock Washer: M6		16x
HW4	Allen Key		1x

SAFAVIEH

C O U T U R E

SFV5302A

DIMENSIONS: 52"L x 18"D x 34"H

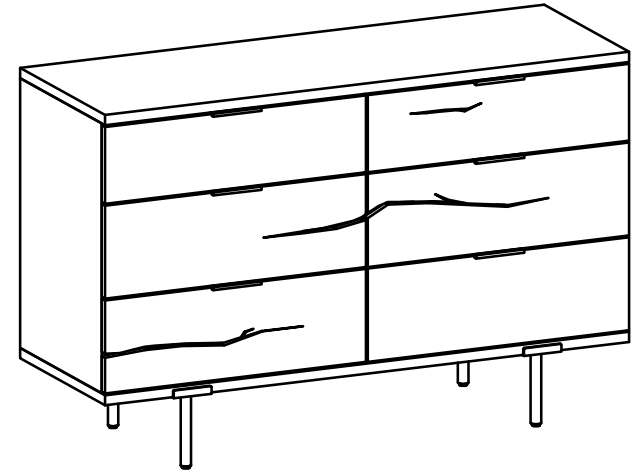

Weight Capacity - 300 LBS

Warning : Do not stand on Chest

Warning : Do not over torque bolts

PREPARATION

- * Before beginning assembly of product, make sure all parts are present. Compare parts with part contents list and hardware contents list.
- * If any part is missing or damaged, do not attempt to assemble the product.
- * Estimated Assembly Time: 15 minutes.
- * Tools Required for Assembly (included): Allen Key
- * If you are having difficulty, our friendly Customer Care team is always here to help. Please email customersupport@safavieh.com

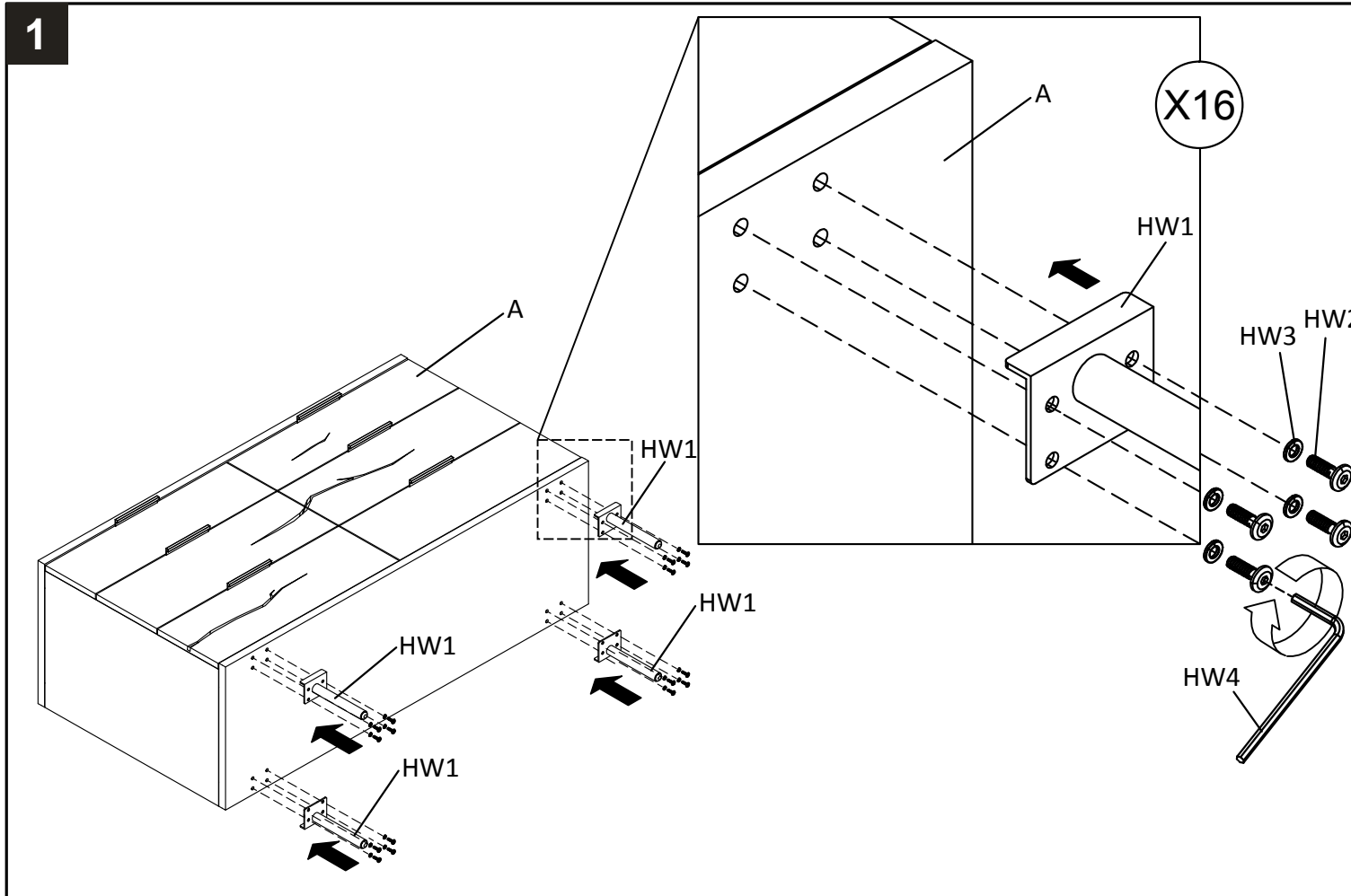

Step 1: Take all package off the dresser. Attach the Metal Legs (HW1) to underneath of the dresser, using Allen Key (HW4) to lock with Allen Bolt (HW2) and Split Lock Washer (HW3).

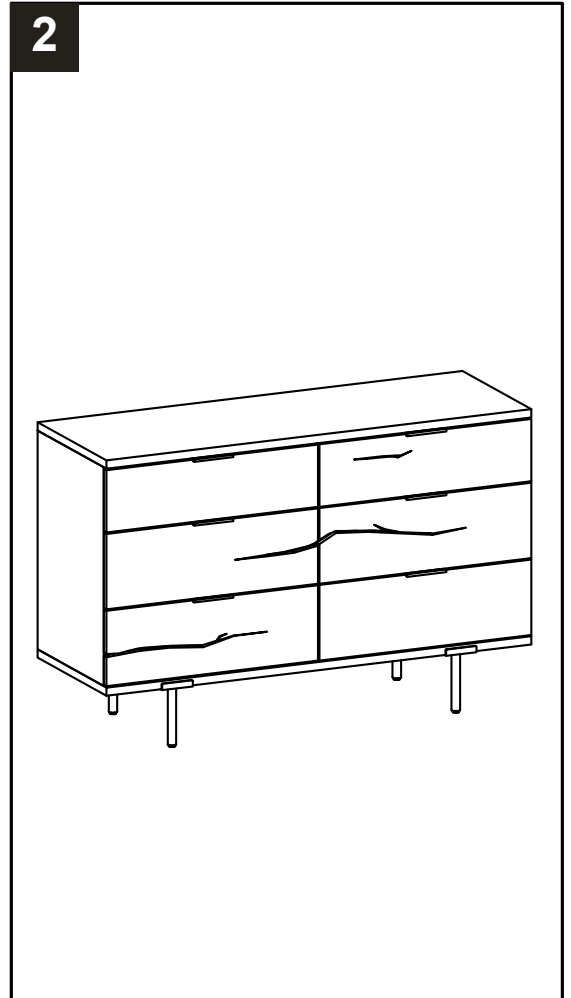

Step 2: Turn the dresser up to front side, adjust the metal legs to make it stable.