

NOTICE

- * Please make sure that you have all parts indicated and they are in good condition before you begin assembly of this item. Refer to part list and hardware list below for guidance.
- * This item should be assembled on a soft surface to prevent scratching the finish during assembly.
- * This item may require periodic tightening.
- * If you are having difficulty, our friendly Customer Care team is always here to help. Please email customersupport@safavieh.com







PREPARATION

- * Before beginning assembly of product, make sure all parts are present. Compare parts with part contents list and hardware contents list.
- * If any part is missing or damaged, do not attempt to assemble the product.
- * Estimated Assembly Time: 10 minutes.
- * Tools Required for Assembly (included): Allen Key

CARE AND MAINTENANCE

- * Spot clean using a mild water-free solvent. Only a professional cleaner should undertake a complete overall cleaning.
- * The use of steam or water-based cleaners may cause excessive shrinking or staining.

Part List and Hardware List

PIECE	DESCRIPTION	PICTURE	QUANTITY
A	CEMENT DISH		1X
B	FRAMES		3X
C	BRACKET		2X
HW1	BOLT	 Ø6x35	6X
HW2	ALLEN KEY	 Ø4x60	1X
HW3	BOLT	 Ø6x13	6X
HW4	BOLT	 Ø6x55	1X



Item ID: PAT1510

Product Dimension: 53 x 53 x 48 cm

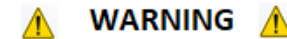
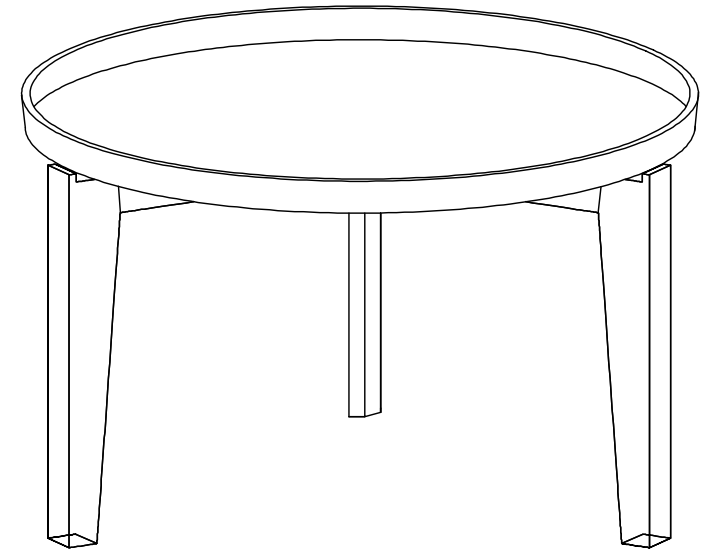

Weight Capacity - 62 LBS

Warning: Do not stand on Pot

Warning: Do not over torque bolts

PREPARATION

- * Before beginning assembly of product, make sure all parts are present. Compare parts with part contents list and hardware contents list.
- * If any part is missing or damaged, do not attempt to assemble the product.
- * Estimated Assembly Time: 10 minutes.
- * Tools Required for Assembly (included): Allen Key
- * If you are having difficulty, our friendly Customer Care team is always here to help. Please email customersupport@safavieh.com

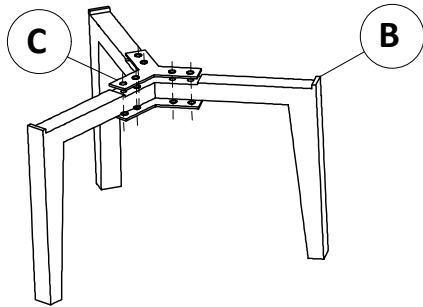

STEP 1: Use bracket (C) to fix the wooden legs: one bar above and one bar below so that 6 holes of the bracket (C) are concentric with the 6 holes available on the wooden legs.

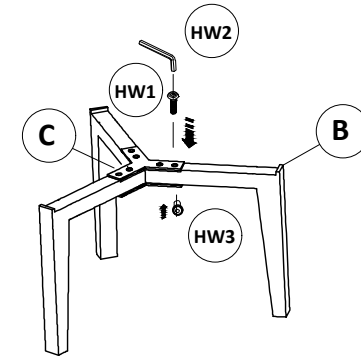

STEP 2: Insert bolt (HW3) from below, Insert bolt (HW1) from top down through the fixed hole earlier. Use allen key (HW2) to tighten slightly. Do the above manipulation for the remaining positions. After inserting all bolts at 6 positions, tighten with sufficient force.

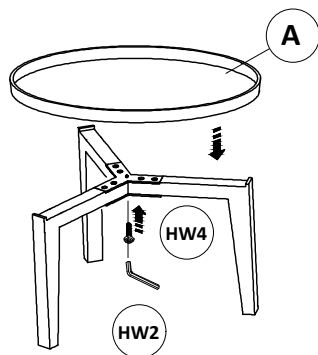

STEP 3: Put the cement dish (A) on the wooden legs and adjust the center of the dish to be concentric with the hole in the center of the bracket (C). Tighten bolt (HW4) with allen key (HW2) but do not tighten strongly to avoid cracking the dish.

