

NOTICE

- * Please make sure that you have all parts indicated and they are in good condition before you begin assembly of this item. Refer to part list and hardware list below for guidance.
- * This item should be assembled on a soft surface to prevent scratching the finish during assembly.
- * This item may require periodic tightening.
- * If you are having difficulty, our friendly Customer Care team is always here to help. Please email customersupport@safavieh.com











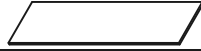

PREPARATION

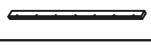
- * Before beginning assembly of product, make sure all parts are present. Compare parts with part contents list and hardware contents list.
- * If any part is missing or damaged, do not attempt to assemble the product.
- * Estimated Assembly Time: 45 minutes.
- * Needed for Assembly: 2 People
- * Tools Required for Assembly : Allen Key (included), Phillips screwdriver (not included).

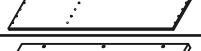
CARE AND MAINTENANCE

Adhesive felt pads should always be applied to areas of furniture which make direct contact with flooring, said application will prevent damage to the furniture and or surfaces on which the furniture lies. Objects placed on articles of furniture should rest on non abrasive material as to prevent damage to the wood finish. Wipe up spills immediately and avoid common hazards such as hot dishes, harsh solvents and abrasives. Cleaning should be done with a soft lint free cotton cloth dampened with water or furniture polish.

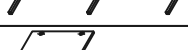
Part List and Hardware List

PIECE	DESCRIPTION	PICTURE	QUANTITY
A	TOP PANEL		1X
B	SIDE PANEL		2X
C	DIVIDER		1X
D	ADJUSTABLE SHELF 1		1X
E	ADJUSTABLE SHELF 2		1X
F	RAIL ADJUSTABLE SHELF 1		1X
G	RAIL ADJUSTABLE SHELF 2		1X
H	RAIL		1X
I	BOTTOM PANEL		1X
J	UPPER BACK PANEL		1X
K	LOWER BACK PANEL		1X
L	FRONT FRAME		3X
M	BOTTOM FRAME		1X
N	BACK FRAME		1X
O	DOOR		3X

SAFAVIEH FURNITURE

Model# MED5007

Product Dimensions: 54"W x 15"D x 35"H

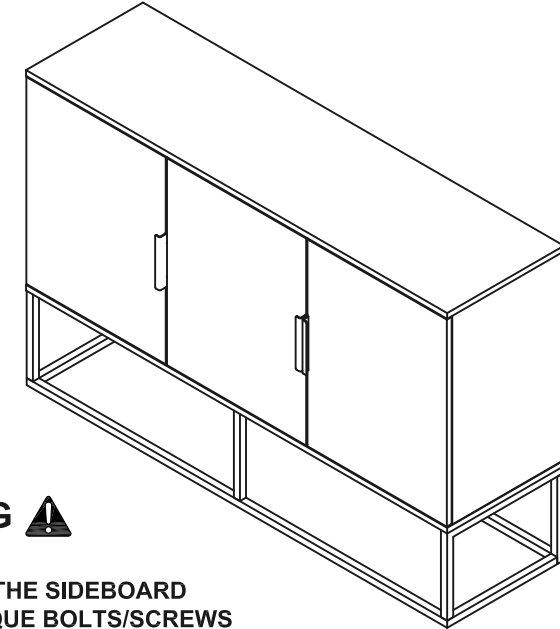









WARNING



WEIGHT CAPACITY: 50 LBS

WARNING: DO NOT STAND ON THE SIDEBOARD

WARNING: DO NOT OVER TORQUE BOLTS/SCREWS

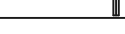
PIECE	DESCRIPTION	PICTURE	QUANTITY
HW1	BOLT 6 x 1 x 30 MM		14X
HW2	FLAT HEAD SCREW 3 x 1 x 19 MM		6X
HW3	ROUND HEAD SCREW 3 x 1 x 13 MM		24X
HW4	CAMBOLT		43X
HW5	CAMLOCK		43X
HW6	HINGE		6X
HW7	SHELF SUPPORT PIN		8X
HW8	HANDLE		3X
HW9	DOWEL		20X
HW10	ALLEN KEY		1X

PREPARATION

- * Before beginning assembly of product, make sure all parts are present. Compare parts with part contents list and hardware contents list.
- * If any part is missing or damaged, do not attempt to assemble the product.
- * Estimated Assembly Time: 45 minutes.
- * Needed for Assembly: 2 People
- * Tools Required for Assembly : Allen Key (included), Phillips screwdriver (not included).
- * If you are having difficulty, our friendly Customer Care team is always here to help. Please email customersupport@safavieh.com

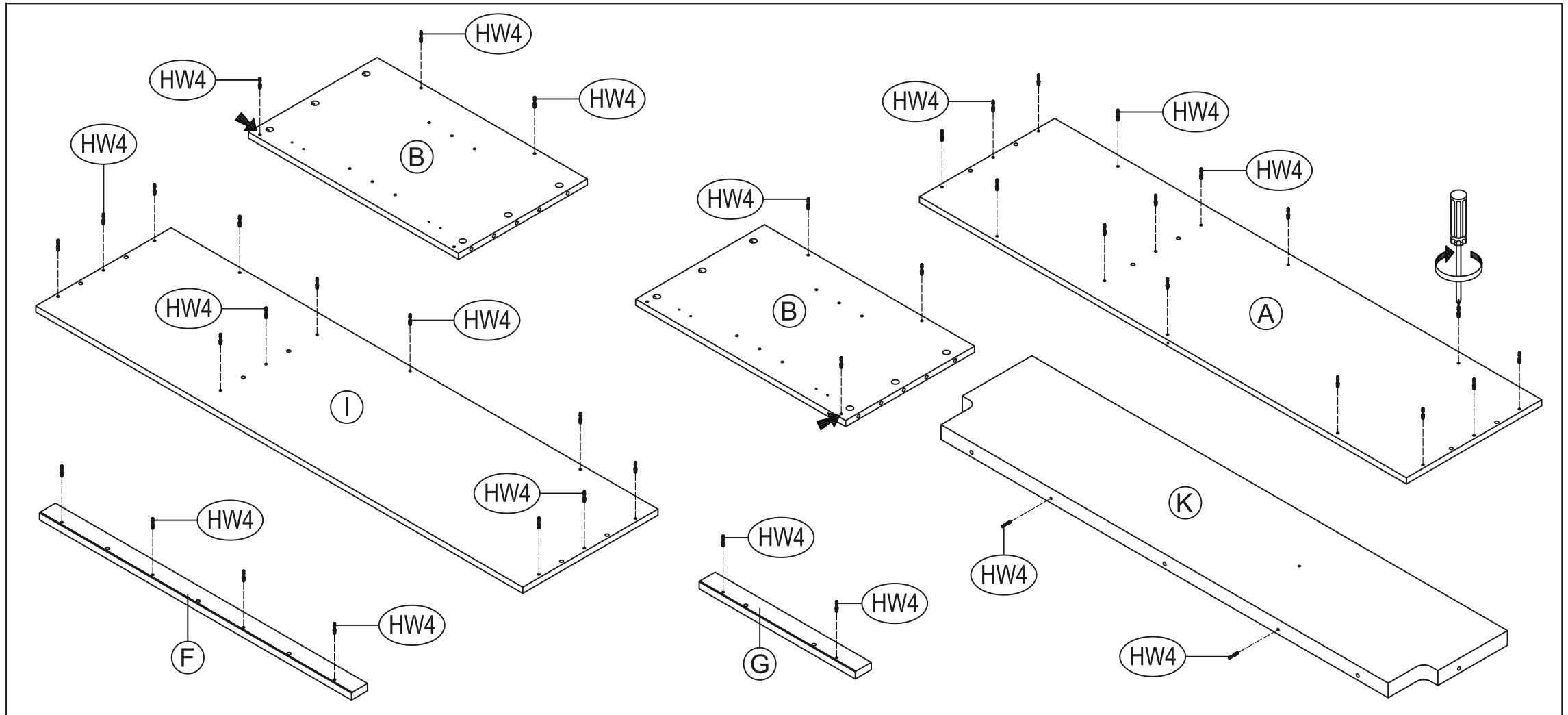

STEP 1 ATTACH CAMBOLTS (HW4) TO TOP PANEL (A), SIDE PANELS (B), BOTTOM PANEL (I), RAIL ADJUSTABLE SHELF 1 (F), RAIL ADJUSTABLE SHELF 2 (G), AND LOWER BACK PANEL (K).

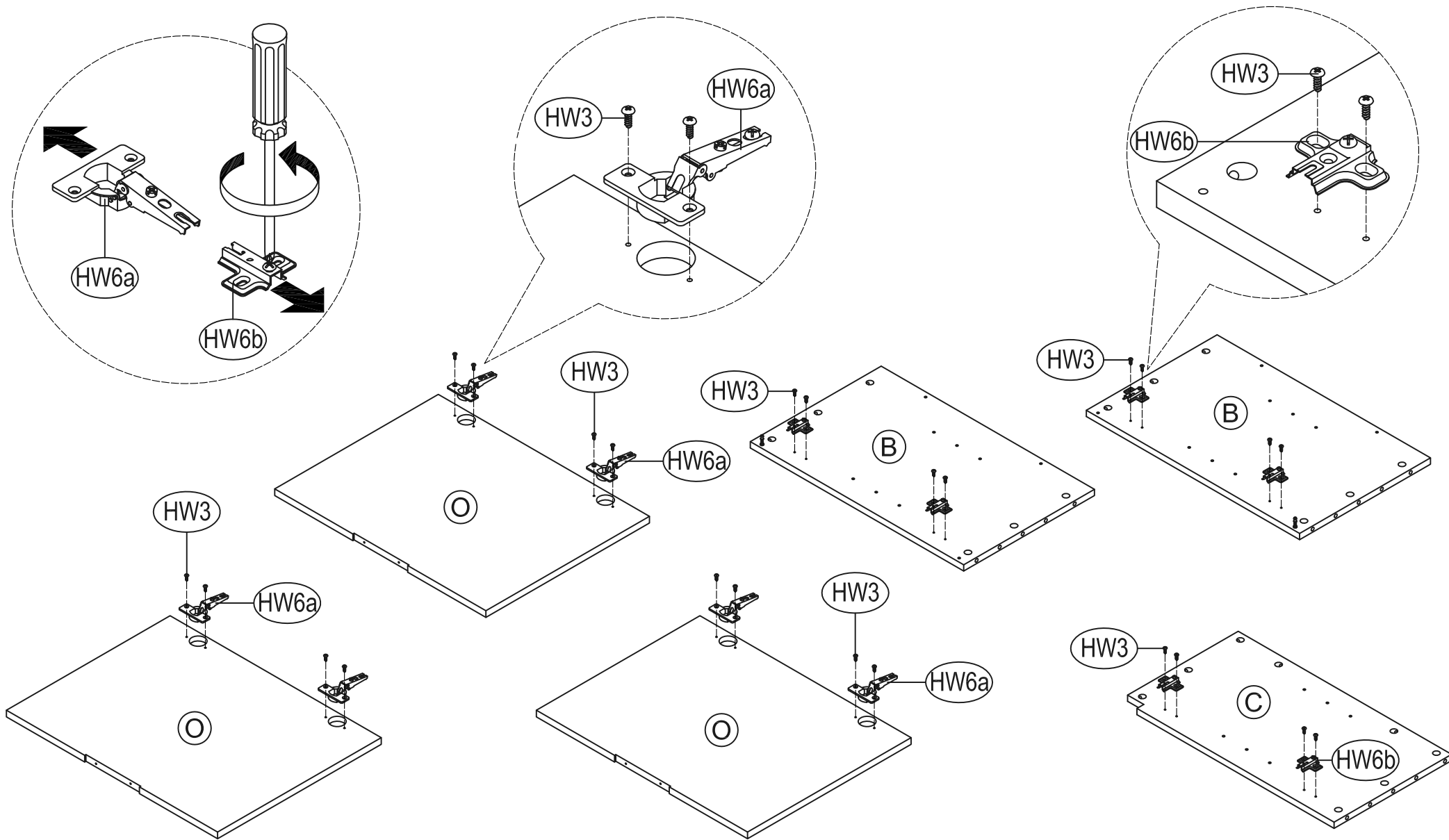

STEP 2 DETACH THE HINGE FROM THE BASE. ATTACH HINGE BASES (HW6b) TO SIDE PANELS (B) AND DIVIDER (C) USING 1/2" ROUND HEAD SCREWS (HW3). ATTACH HINGES (HW6a) TO DOORS (O) USING 1/2" ROUND HEAD SCREWS (HW3).

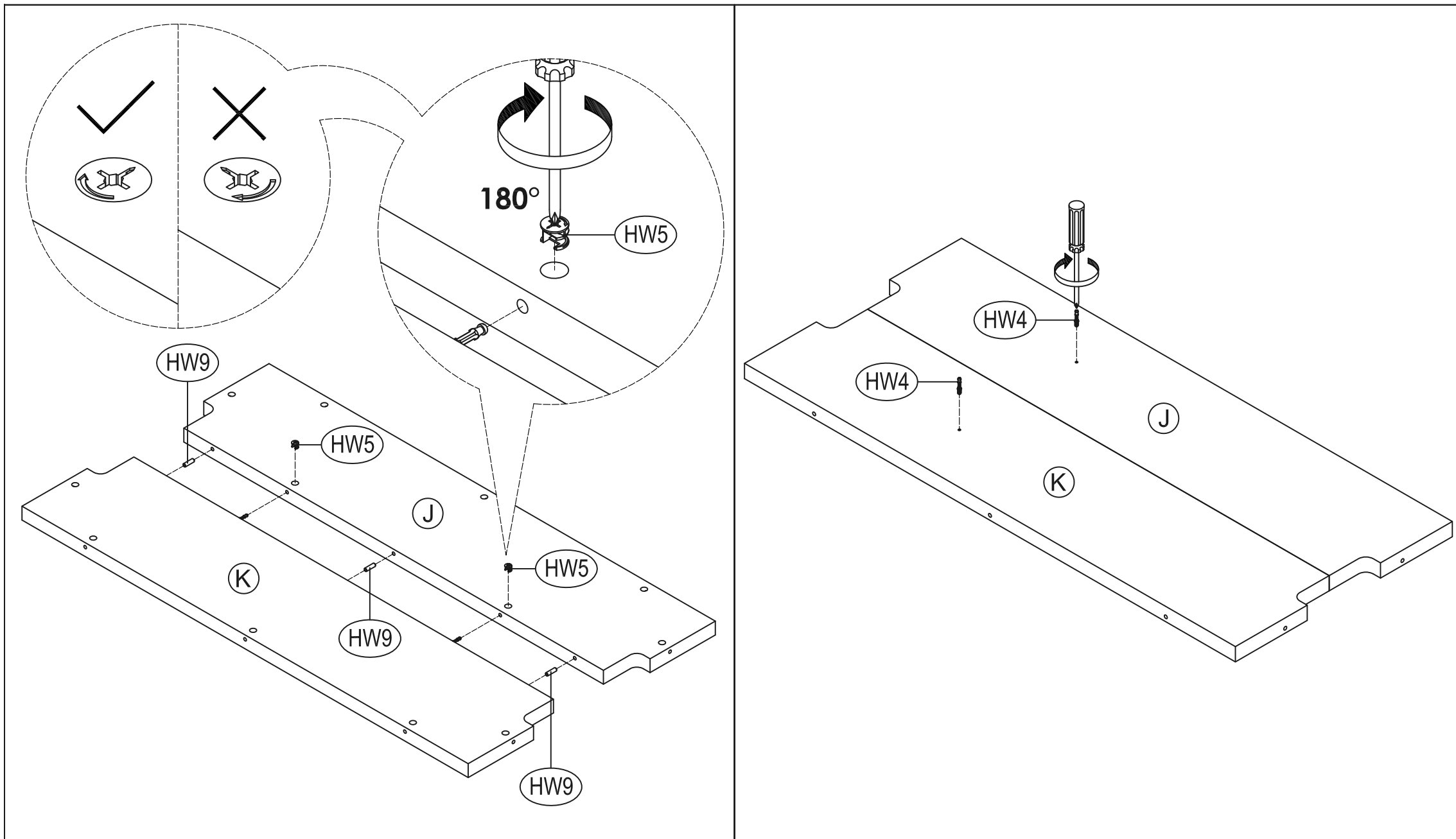

STEP 5 JOIN UPPER AND LOWER BACK PANELS (J) AND (K) USING CAMLOCKS (HW5) AND DOWELS (HW9).

STEP 6 ATTACH CAMBOLTS (HW4) TO UPPER AND LOWER BACK PANELS (J) AND (K).

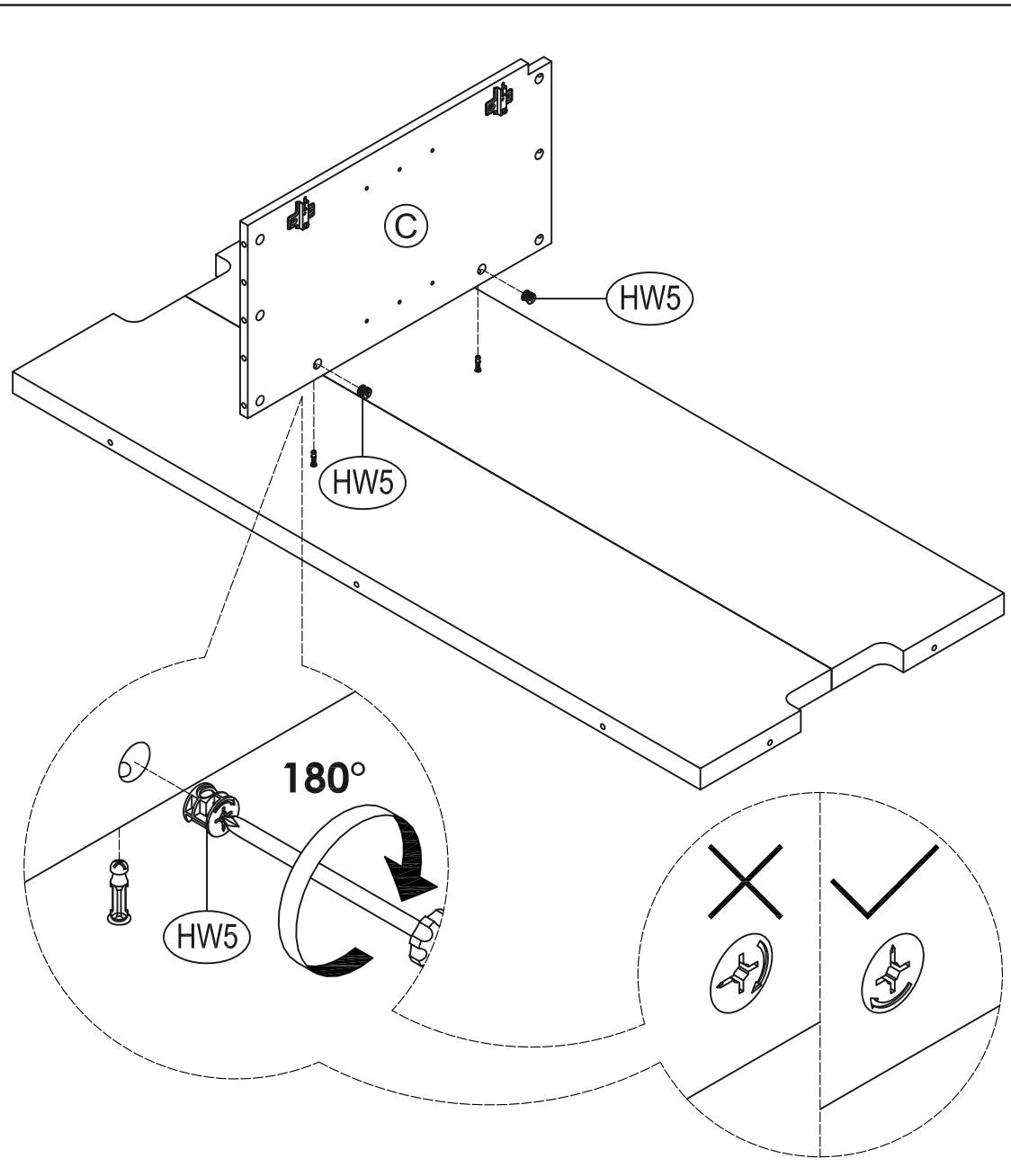

STEP 7 ATTACH DIVIDER (C) TO ASSEMBLY BACK PANEL USING CAMLOCKS (HW5).

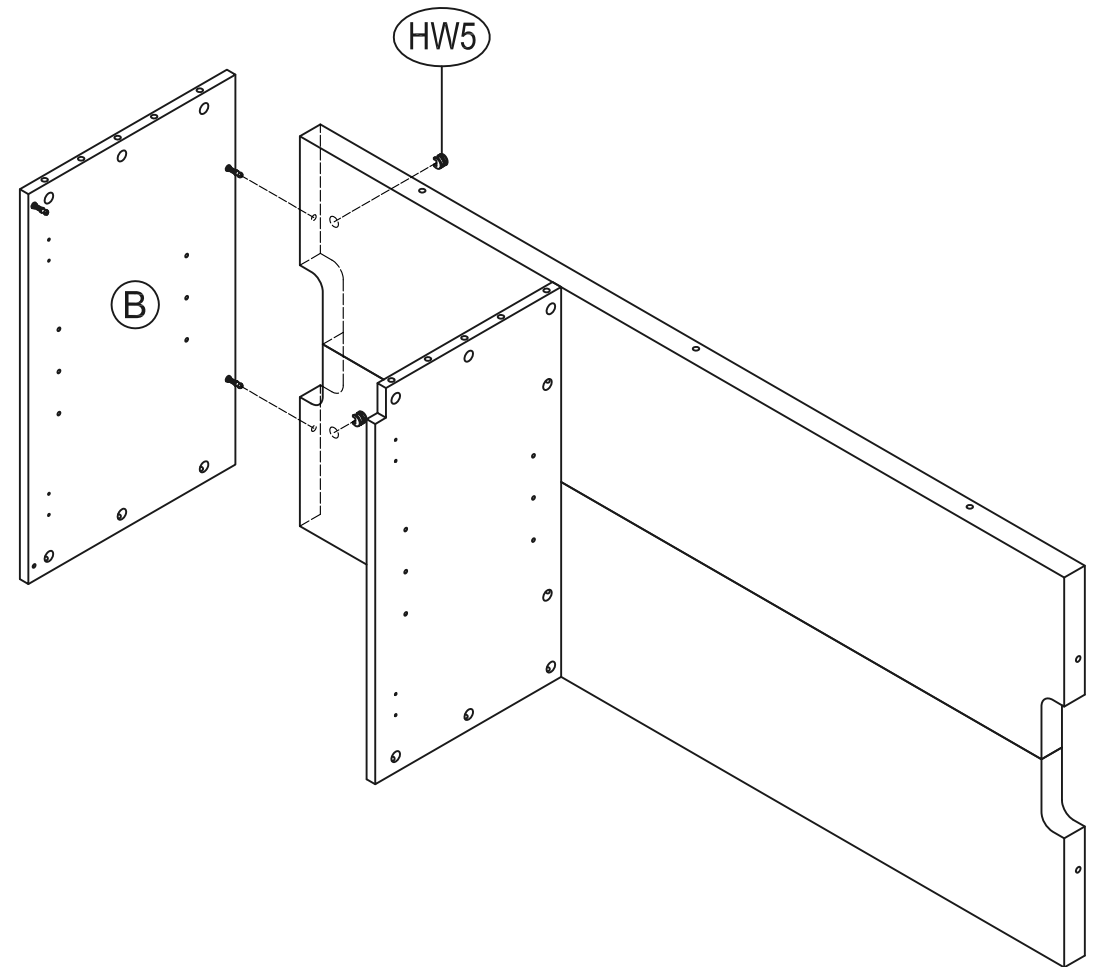

STEP 8 ATTACH SIDE PANEL (B) TO UNIT USING CAMLOCKS (HW5).

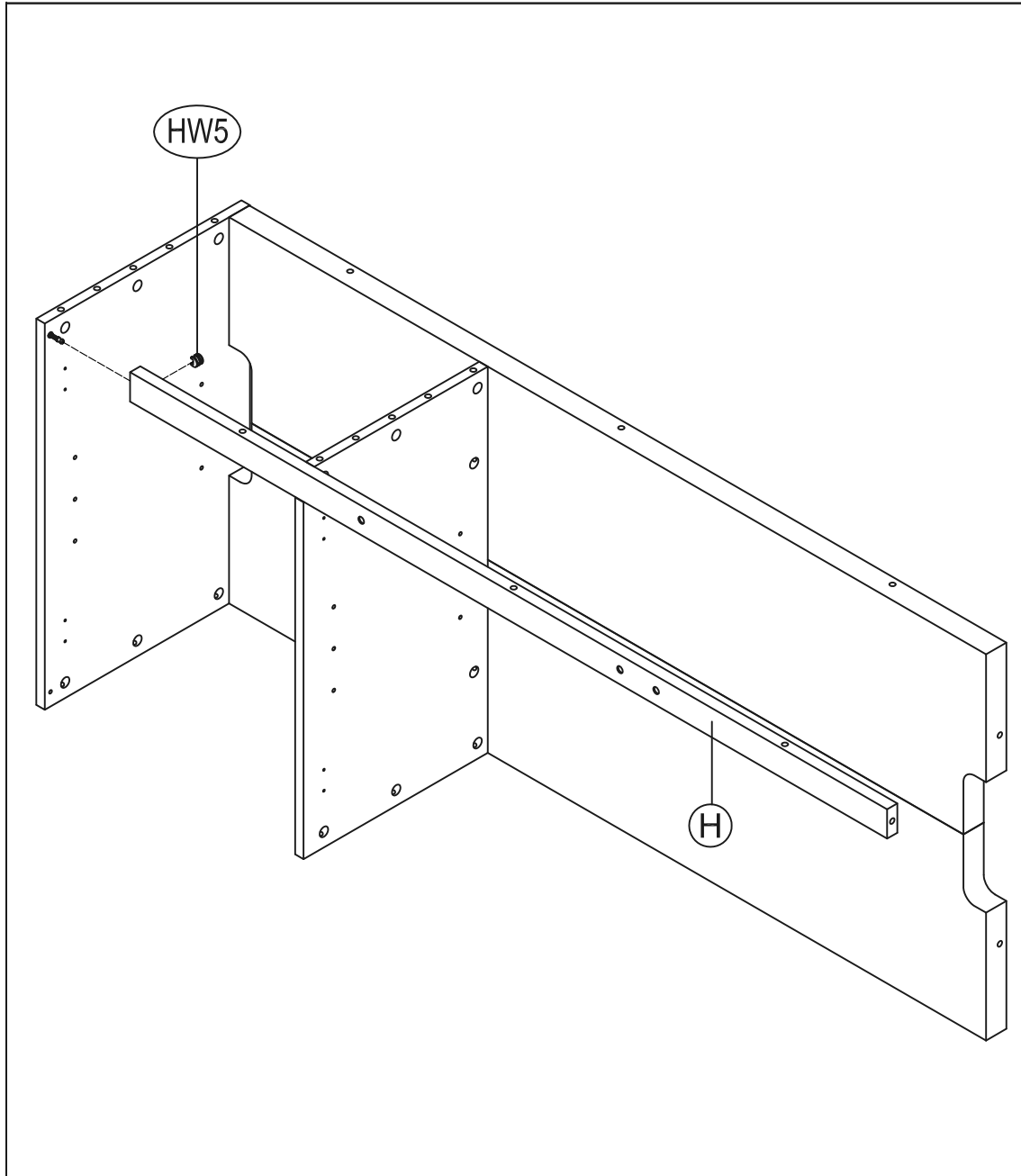

STEP 9 ATTACH RAIL (H) TO UNIT USING CAMLOCK (HW5).

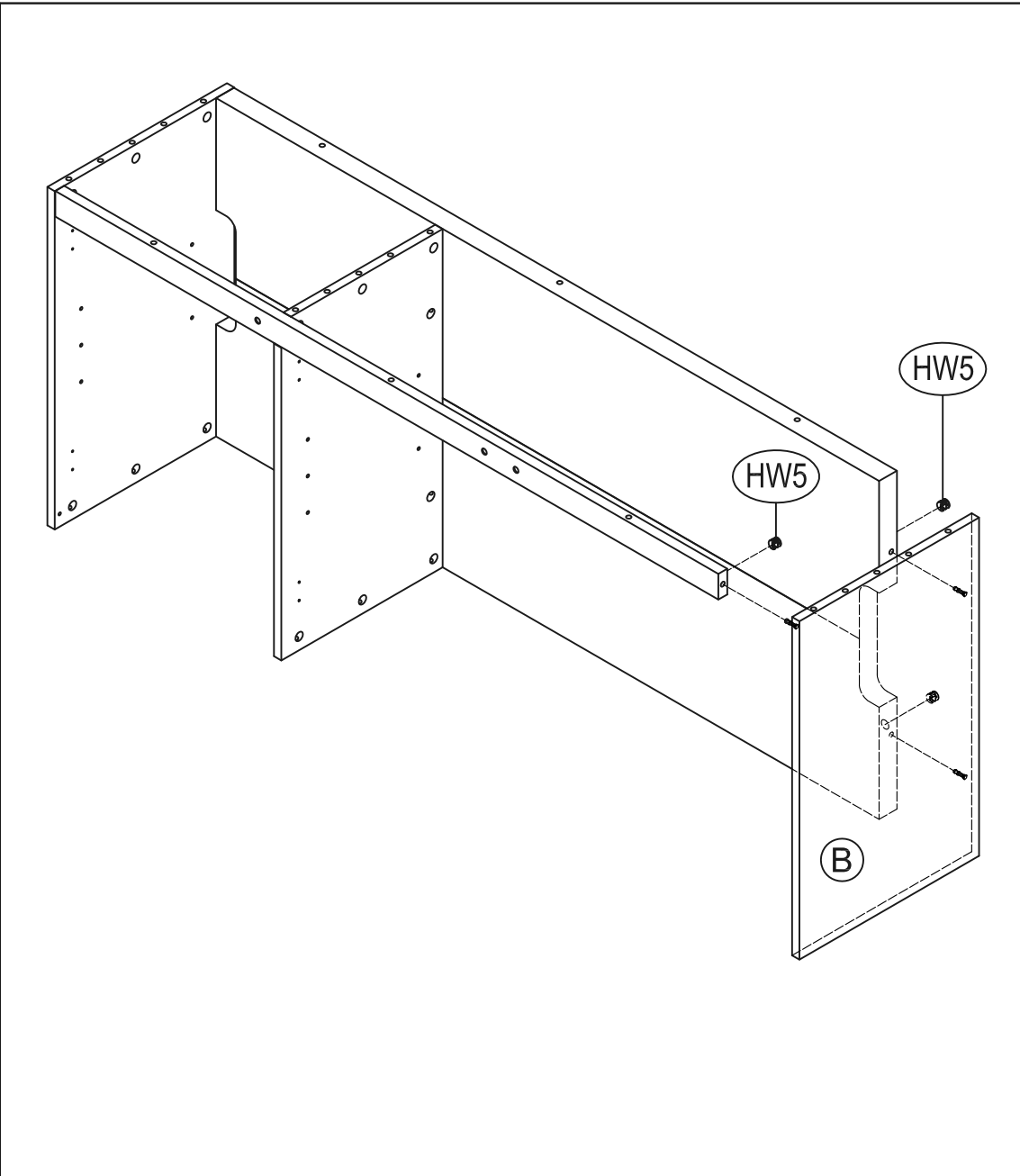

STEP 10 ATTACH SIDE PANEL (B) TO UNIT USING CAMLOCKS (HW5).

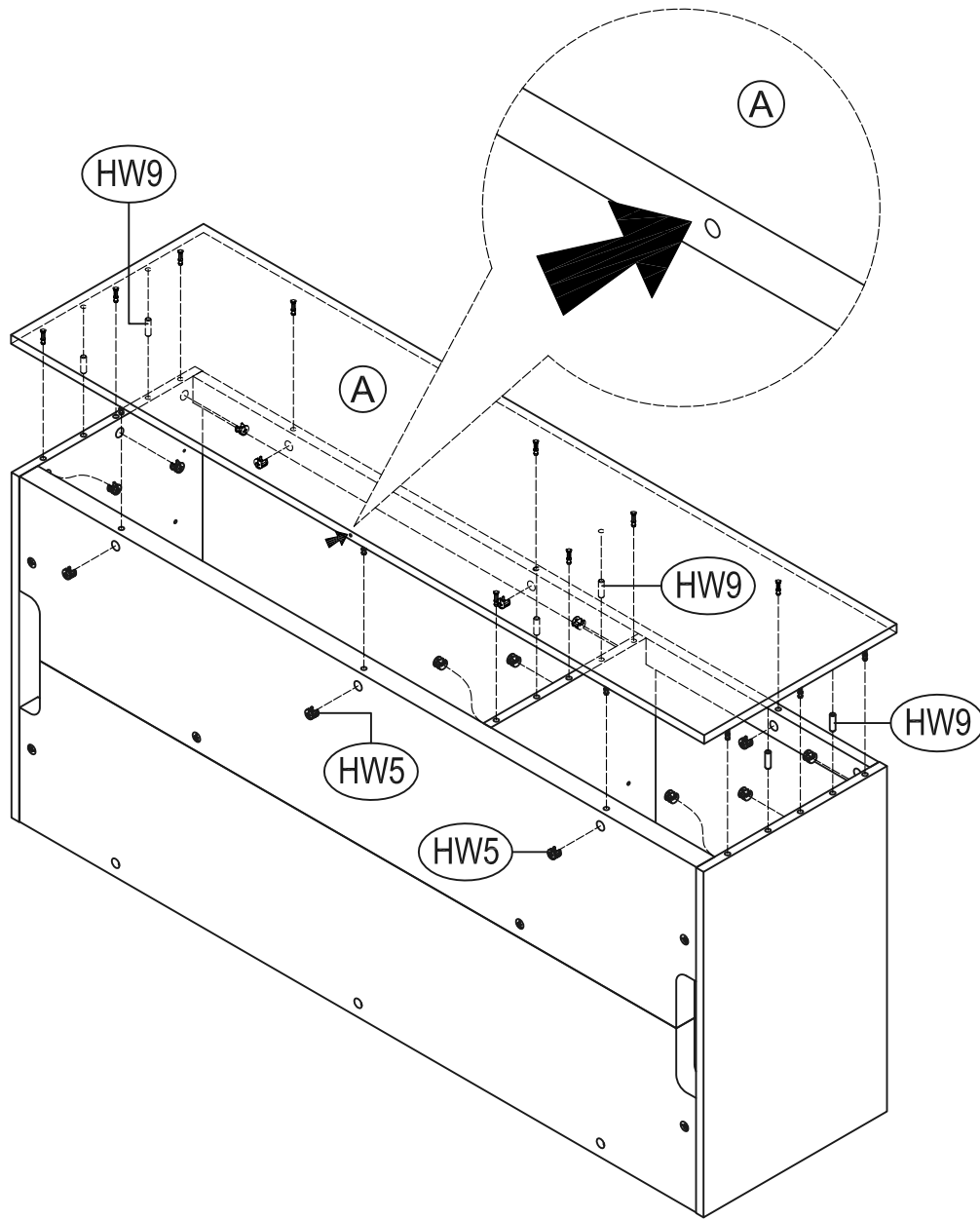

STEP 11 ATTACH TOP (A) TO UNIT USING CAMLOCK (HW5) AND DOWELS (HW9).

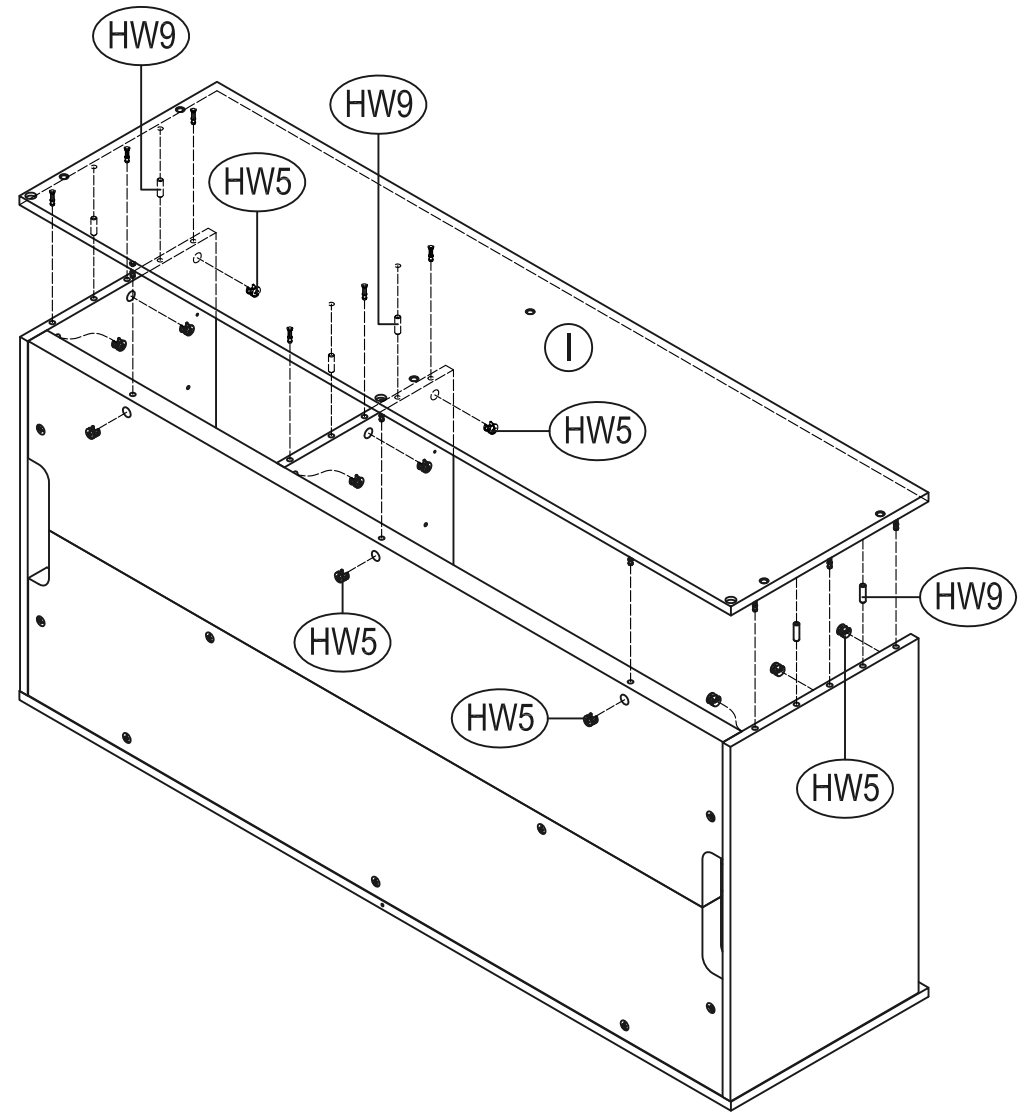

STEP 12 ATTACH BOTTOM PANEL (I) TO UNIT USING CAMLOCKS (HW5) AND DOWELS (HW9).

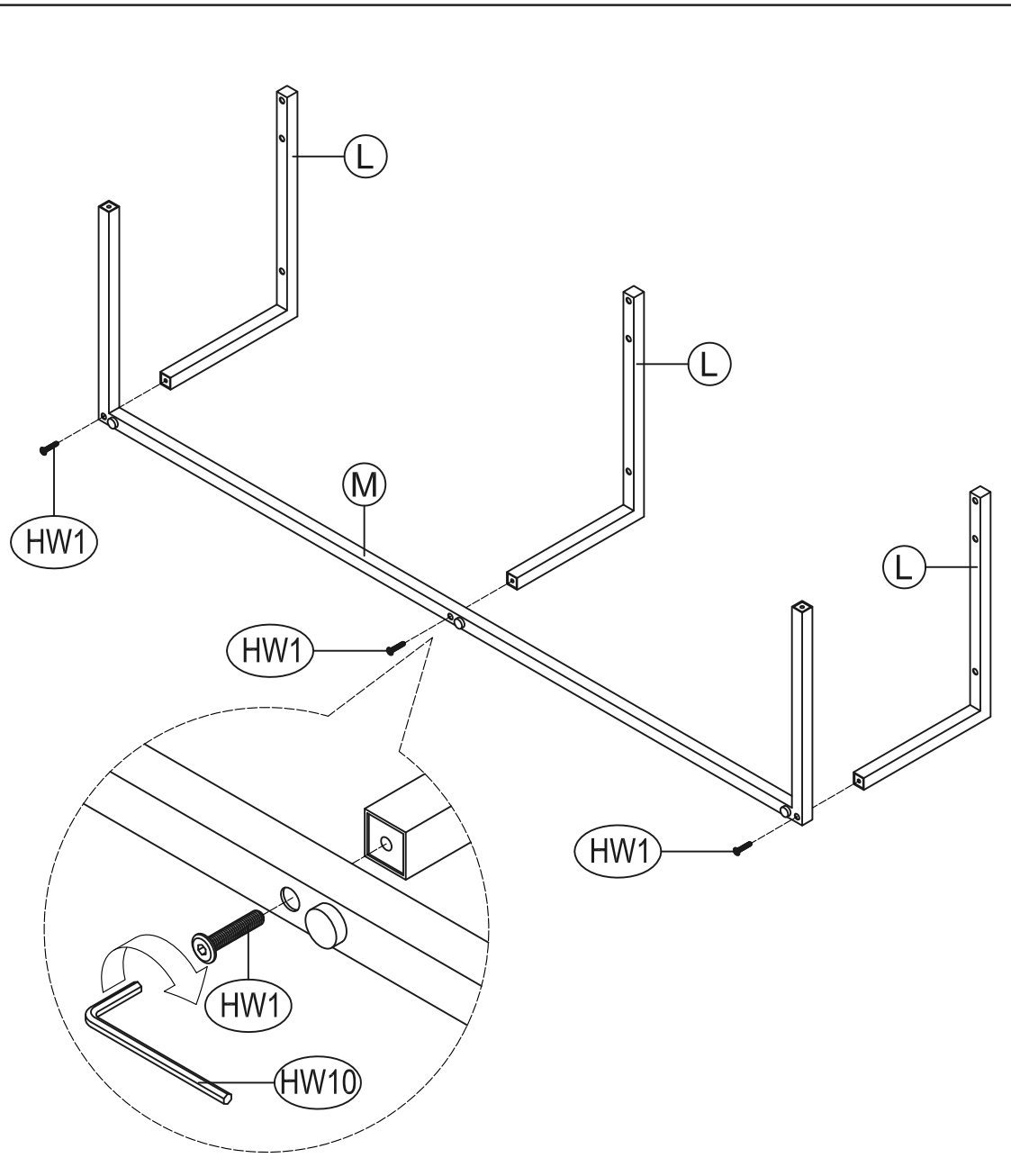

STEP 13 ATTACH FRONT FRAMES (L) TO BOTTOM FRAME (M) USING 30 MM BOLTS (HW1).
NOTE: DO NOT OVER TIGHTEN THE BOLTS.

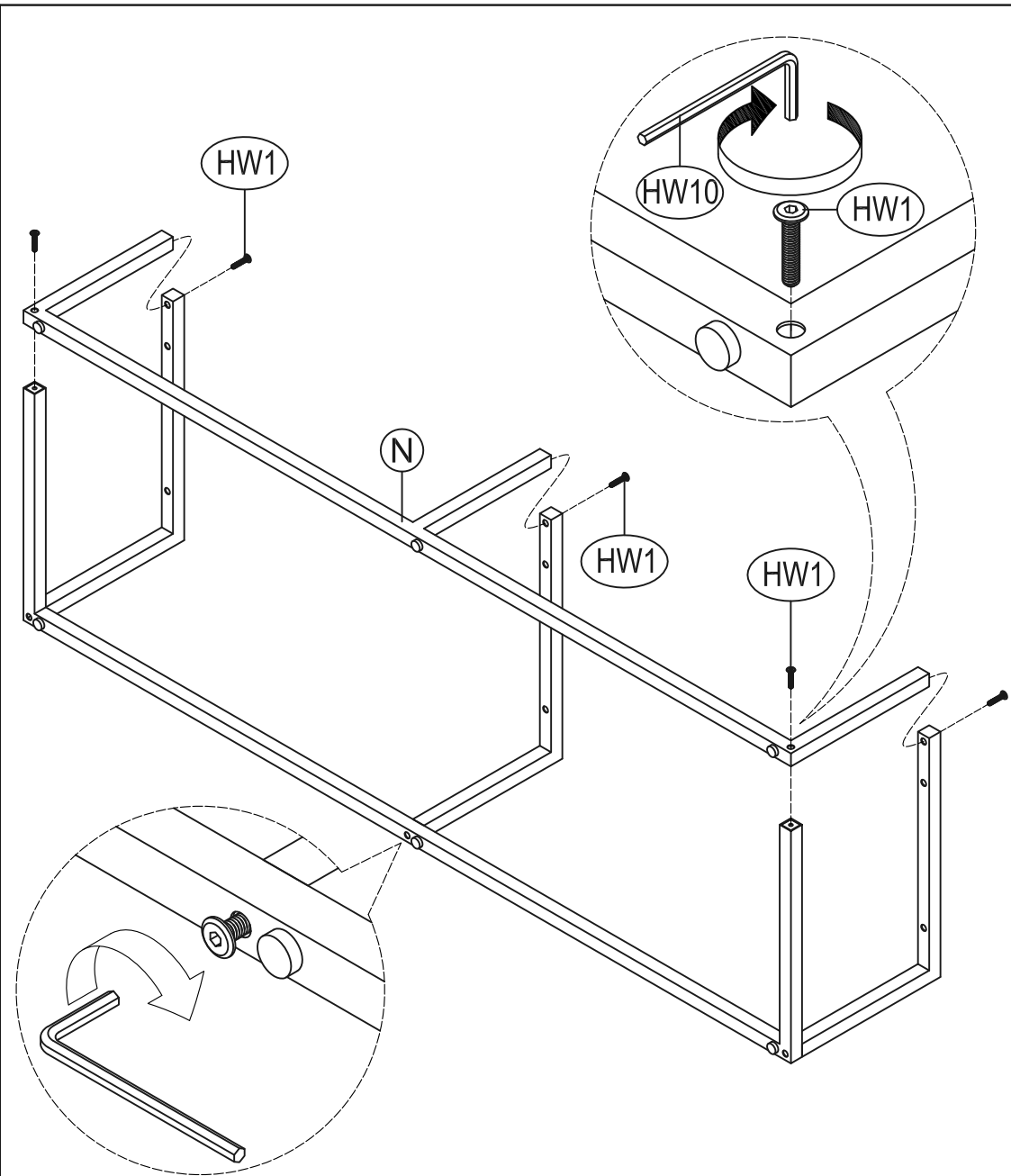

STEP 14 ATTACH BACK FRAME (N) TO FRAME ASSEMBLY USING 30 MM BOLTS (HW1).
NOTE: TIGHTEN ALL THE BOLTS USING ALLEN KEY (HW10).

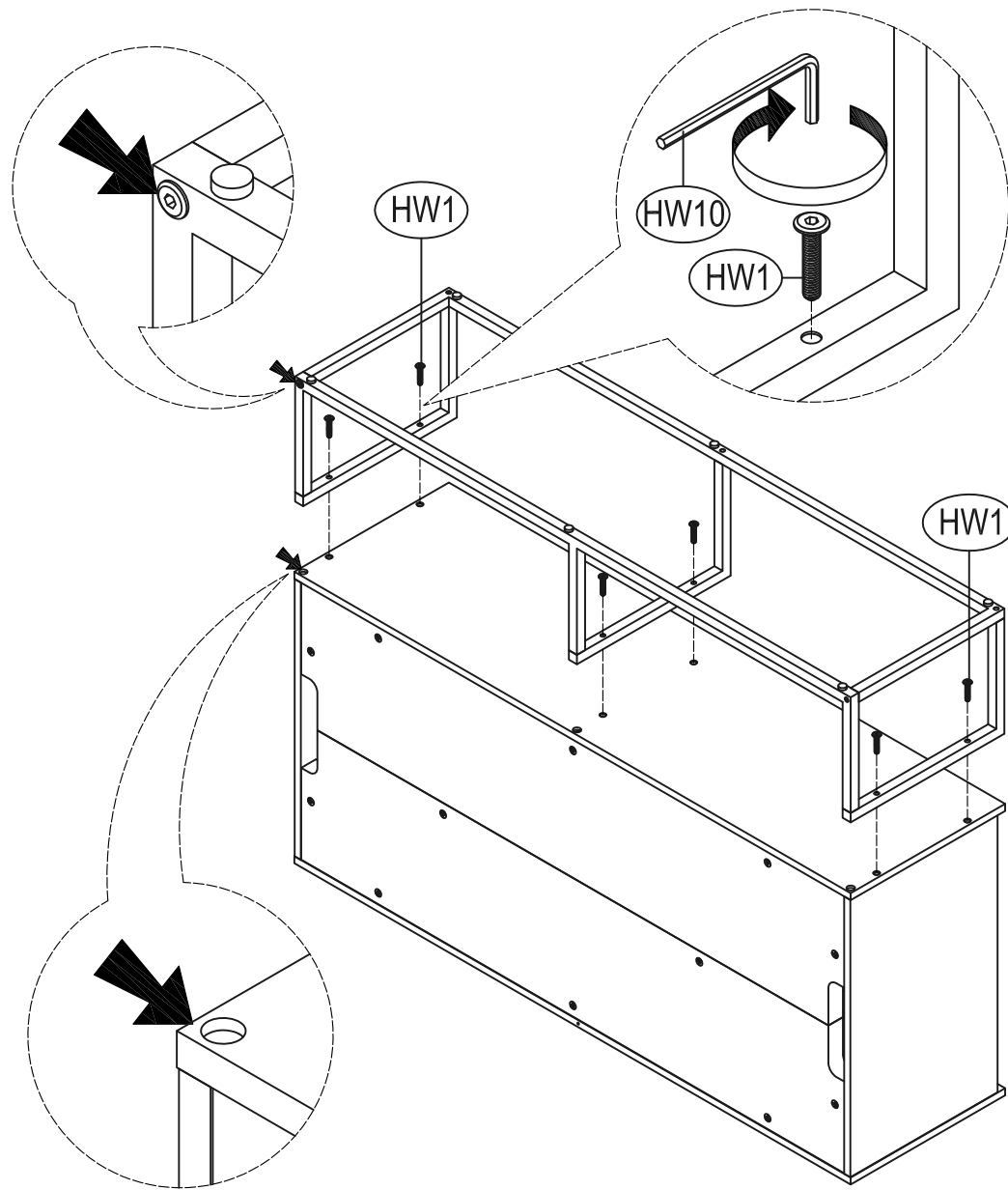

STEP 15 ATTACH FRAME ASSEMBLY TO UNIT USING 30 MM BOLTS (HW1). TIGHTEN THE BOLTS USING ALLEN KEY (HW10).

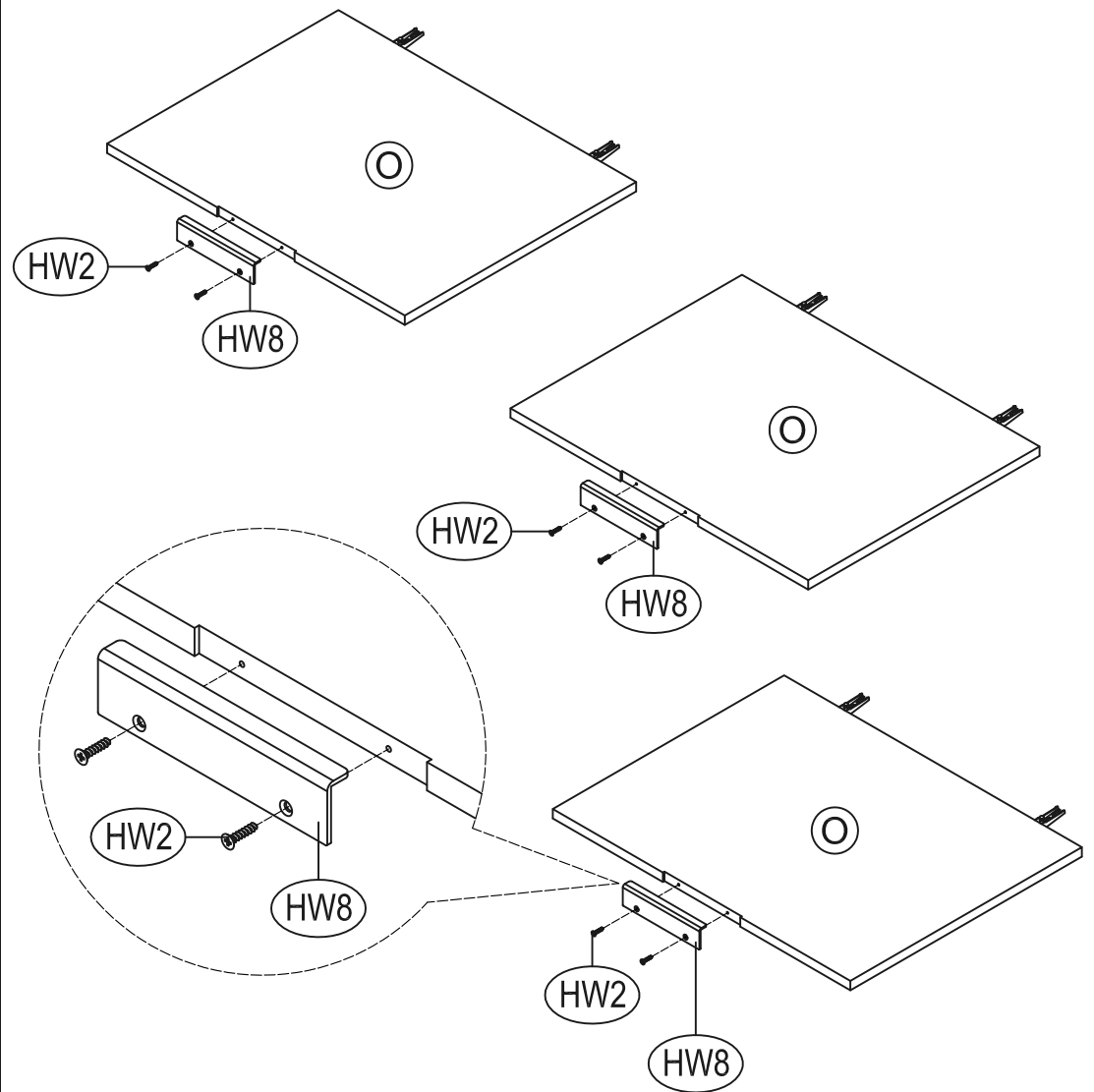

STEP 16 ATTACH HANDLES (HW8) TO DOORS (O) USING 3/4" FLAT HEAD SCREWS (HW2).

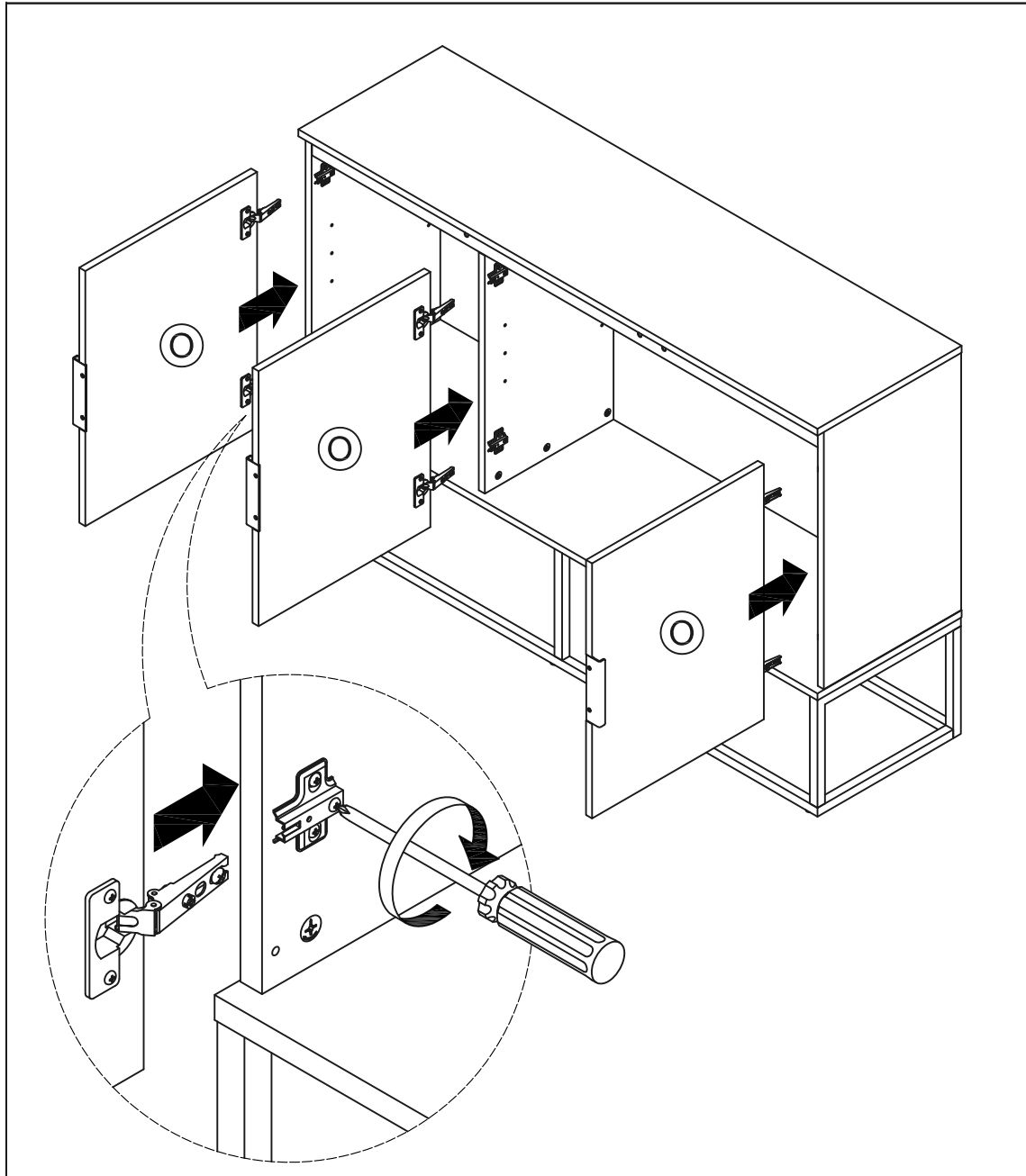

STEP 17 ATTACH DOORS (O) TO UNIT.

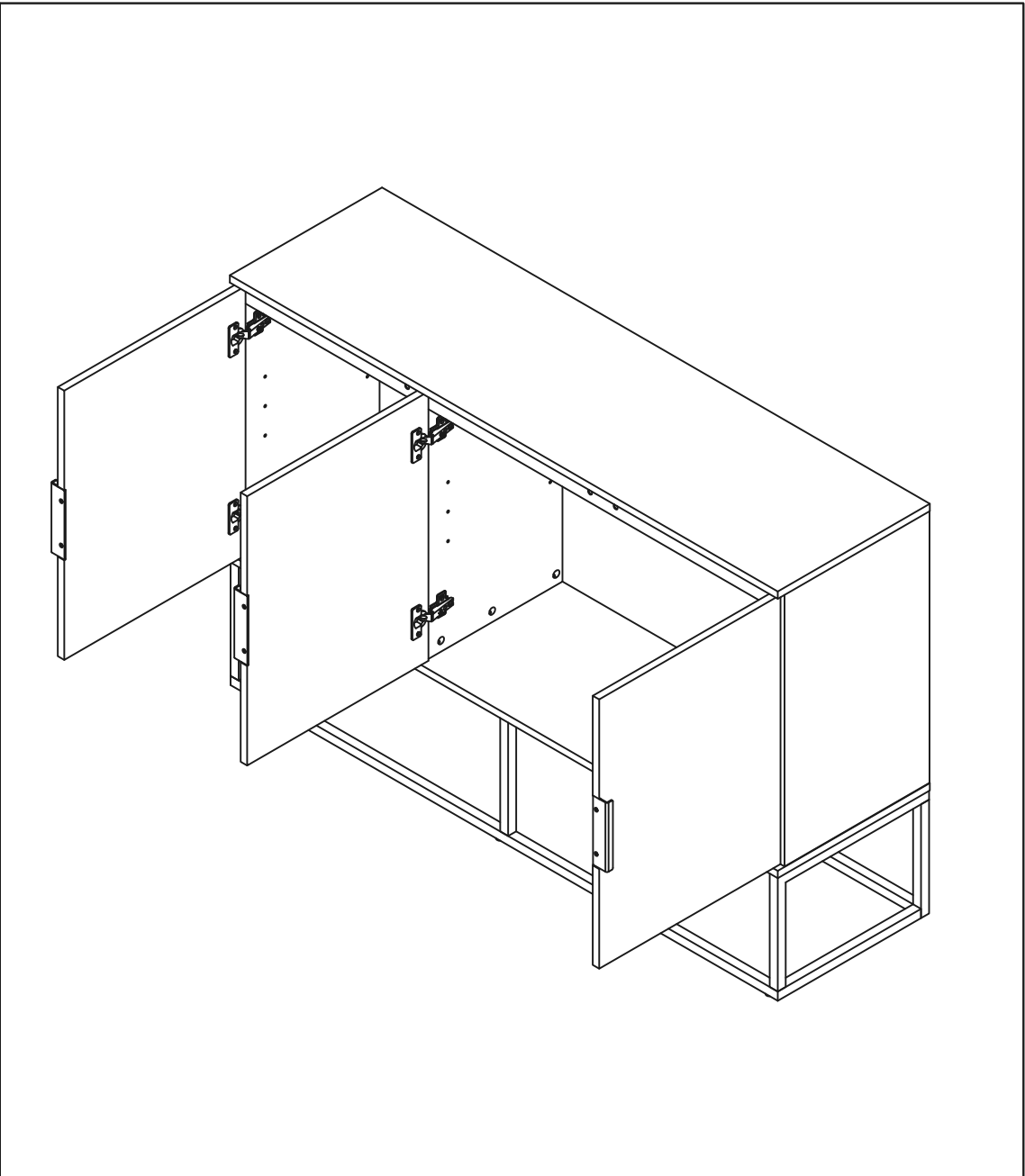

STEP 18 ADJUSTING THE DOORS. REFER TO NEXT PAGE FOR BETTER ILLUSTRATION.

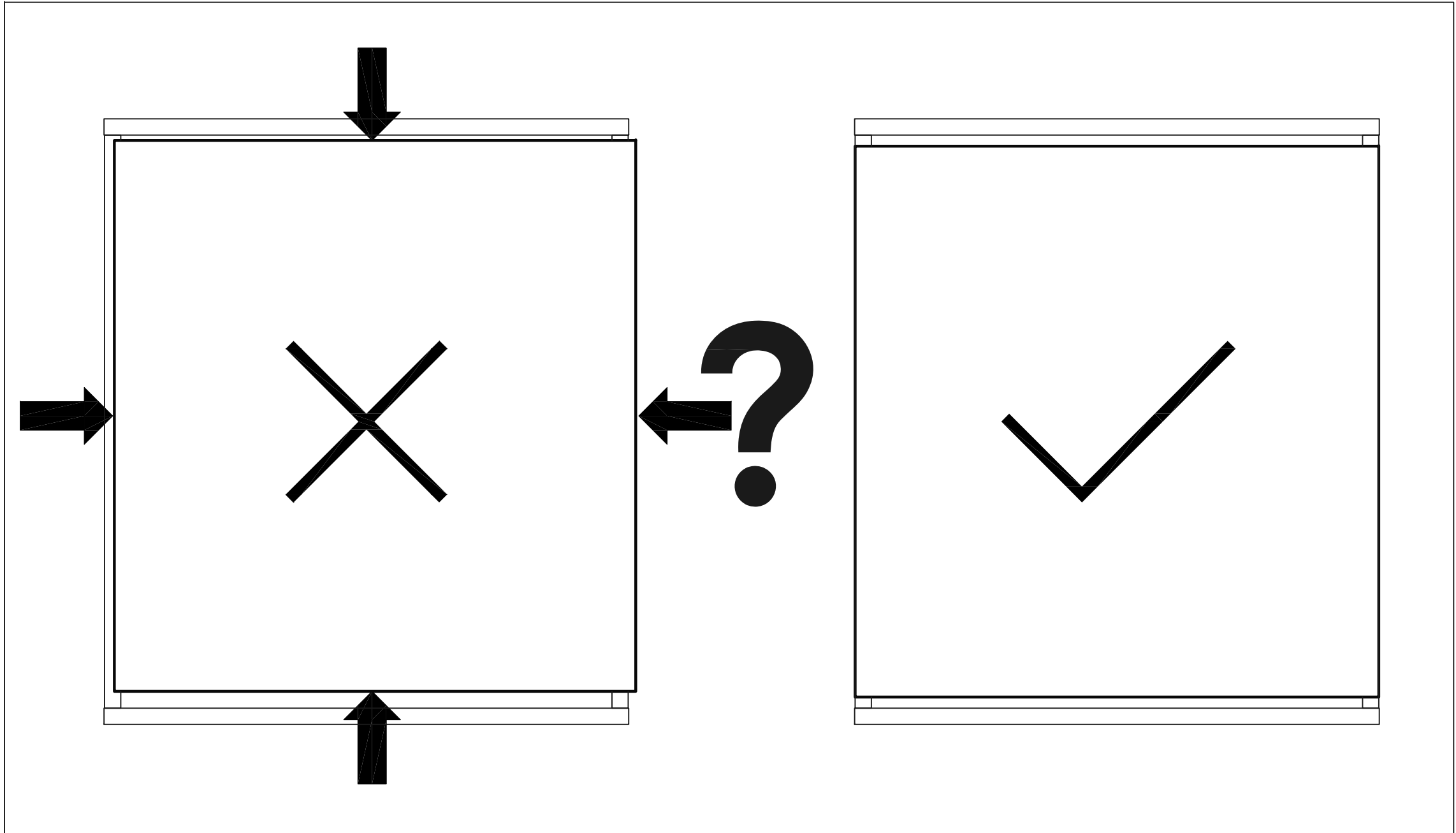

STEP 19 THE GAPS AND EDGES AROUND THE DOOR SHOULD BE BALANCED. IF THE GAPS ARE NOT BALANCED, PLEASE FOLLOW STEPS 16 THROUGH 18.

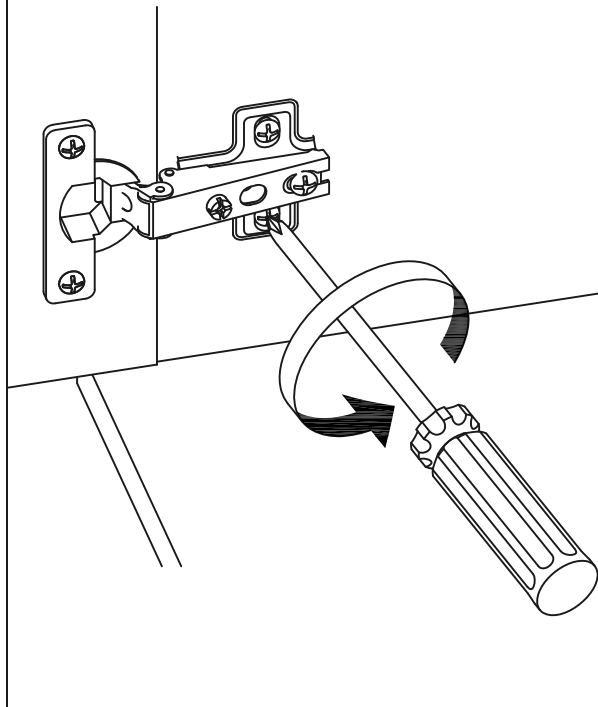
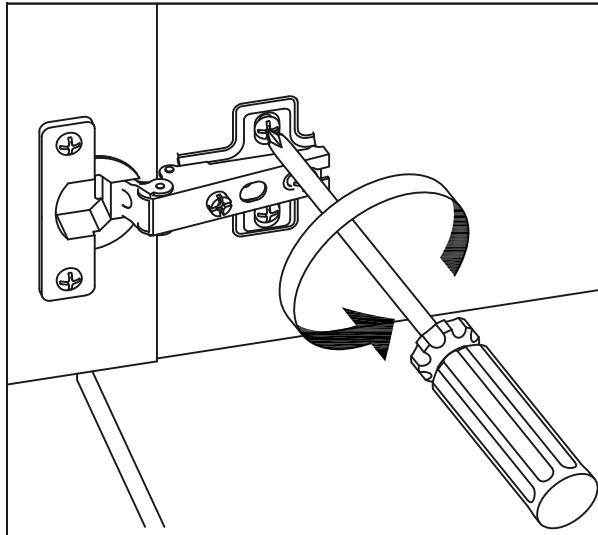

STEP 20.1. IF THE GAP ON THE TOP OR BOTTOM ARE NOT BALANCED, LOOSEN BOTH HINGE BASE SCREWS.

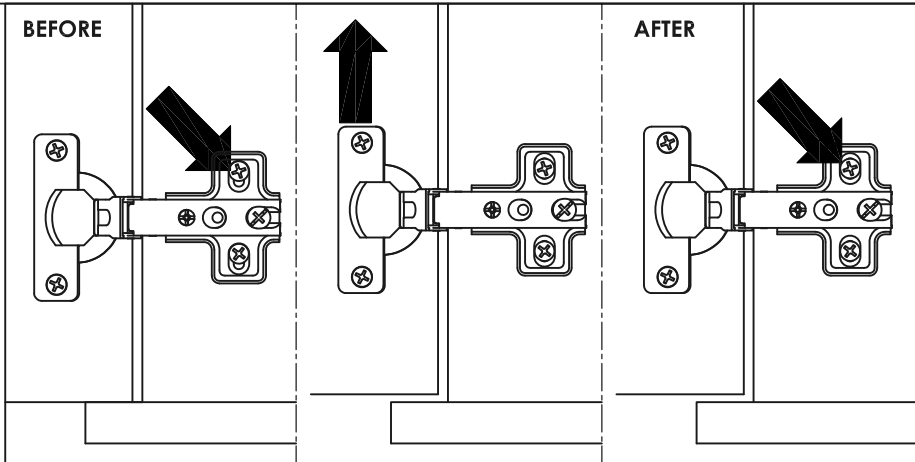

STEP 20.1.1. IF THE GAP ON THE TOP IS TOO WIDE THEN SLIDE THE DOOR SLIGHTLY TO THE TOP.

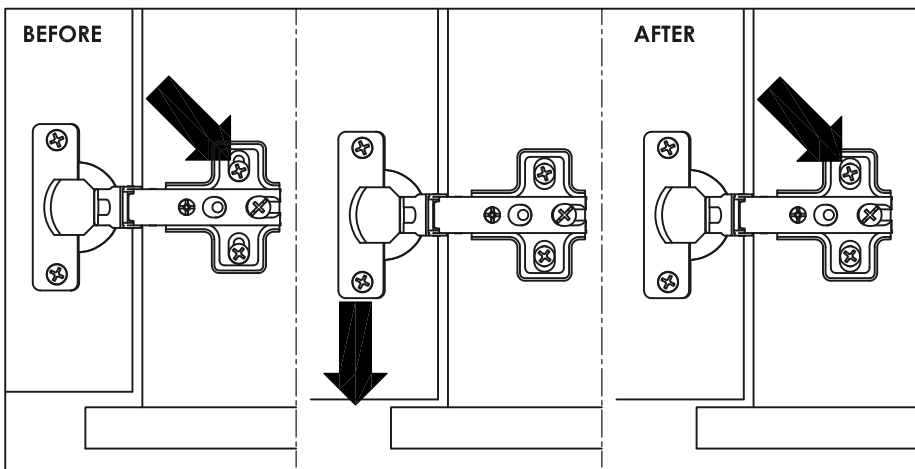

STEP 20.1.2. IF THE GAP ON THE BOTTOM IS TOO WIDE THEN SLIDE THE DOOR SLIGHTLY TO THE BOTTOM.

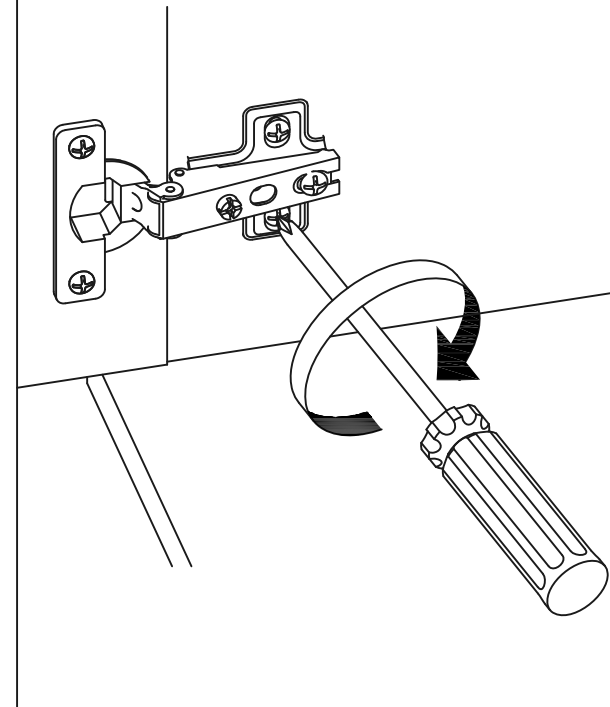
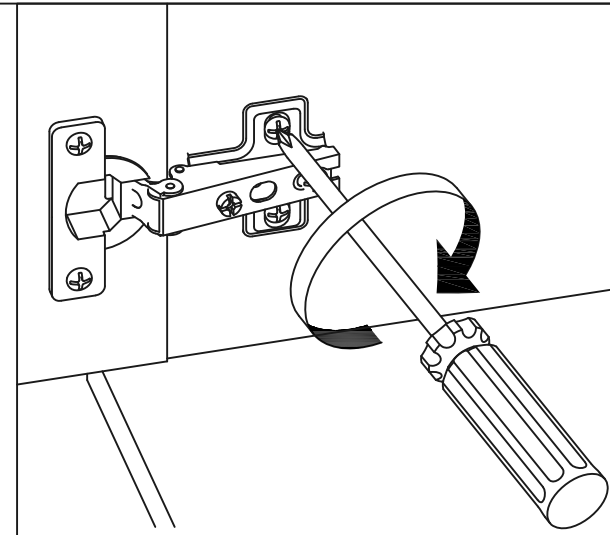

STEP 20.2. TIGHTEN BOTH HINGE BASE SCREWS.

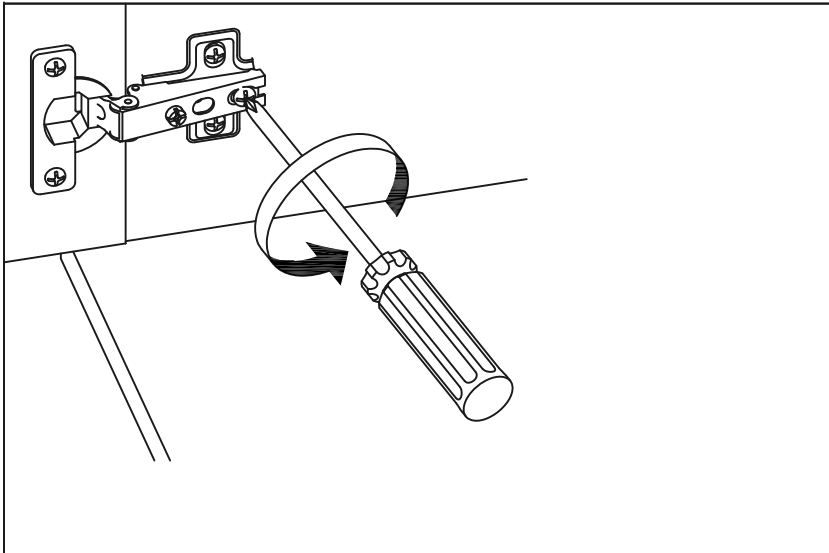

STEP 21.1. IF THE EDGE ON THE LEFT OR RIGHT ARE NOT BALANCE, LOOSEN THE BACK CENTER SCREW.

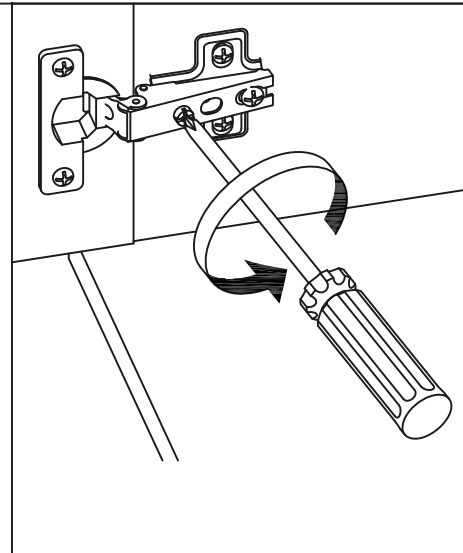

STEP 21.1.1. IF THE EDGE ON THE LEFT SIDE IS TOO WIDE, YOU WILL NEED TO SLIDE THE DOOR SLIGHTLY TO THE LEFT BY TURNING THE FRONT CENTER SCREW COUNTER CLOCKWISE.

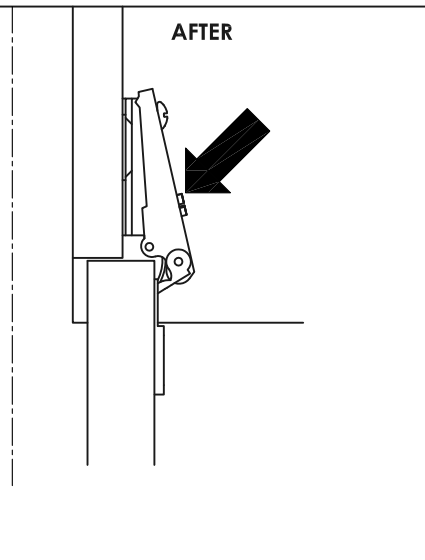
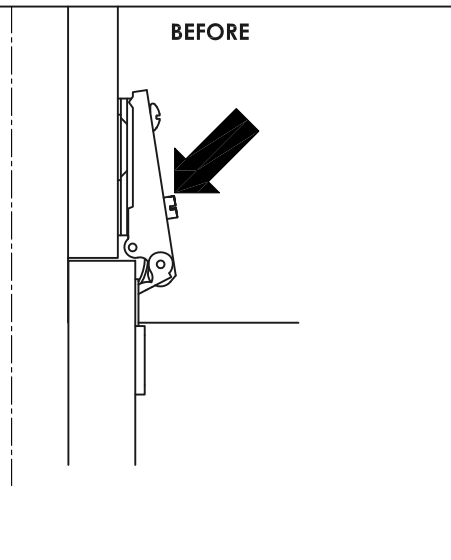
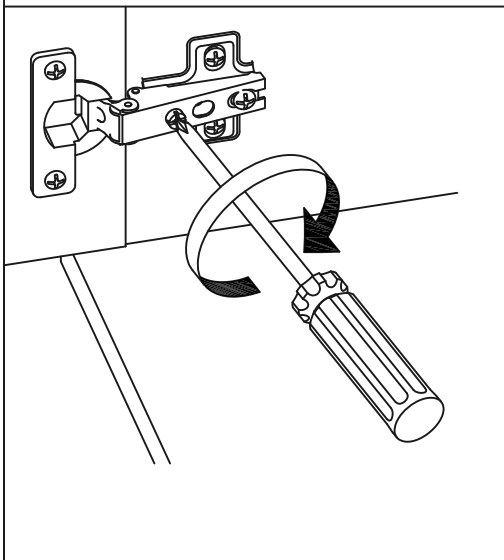
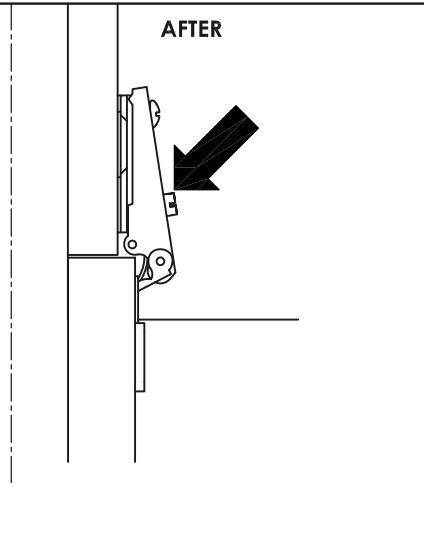
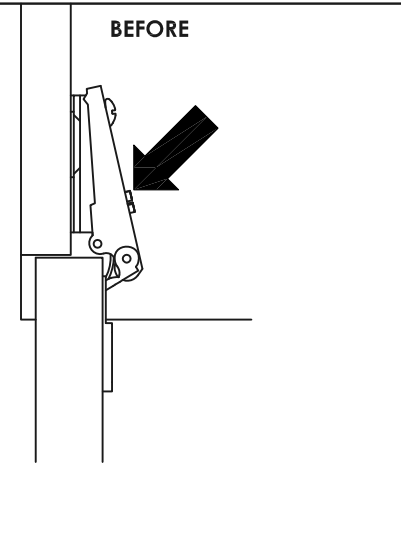

STEP 21.1.2. IF THE EDGE ON THE LEFT SIDE IS TOO NARROW, YOU WILL NEED TO SLIDE THE DOOR SLIGHTLY TO THE RIGHT BY TURNING THE FRONT CENTER SCREW CLOCKWISE.

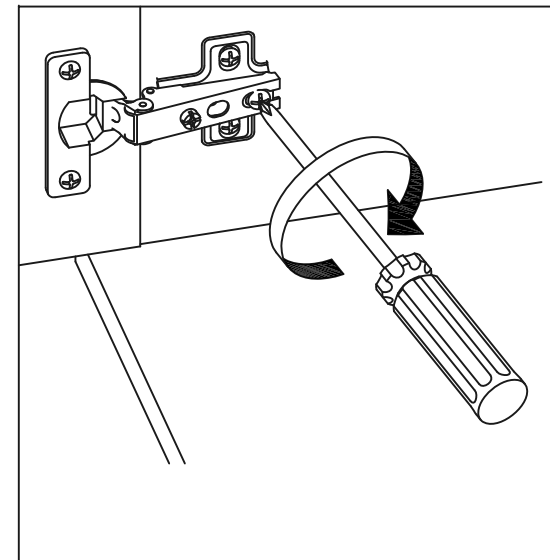

STEP 21.2. TIGHTEN THE BACK CENTER SCREW.

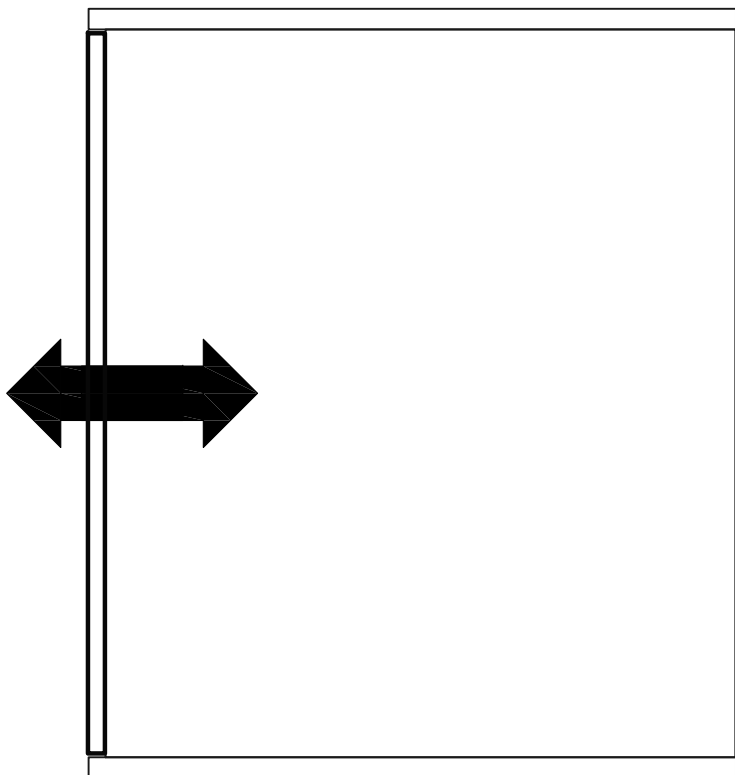

STEP 22.1. IF YOU NEED TO SLIDE THE DOOR FORWARD OR BACKWARD, PLEASE FOLLOW THIS STEP.

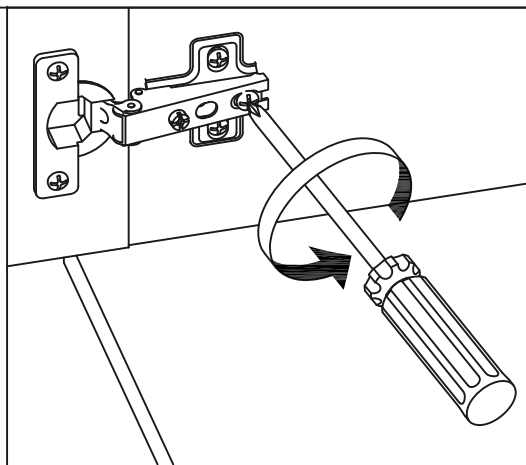

STEP 22.2. LOOSEN THE BACK CENTER SCREW.

BEFORE

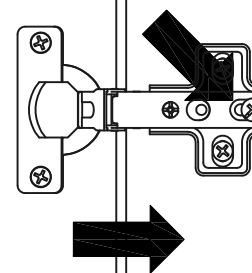

STEP 22.2.1. IF YOU NEED TO SLIDE THE DOOR BACKWARD, PUSH THE DOOR SLIGHTLY.

AFTER

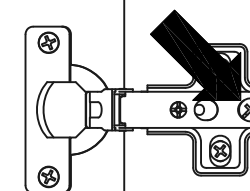

BEFORE

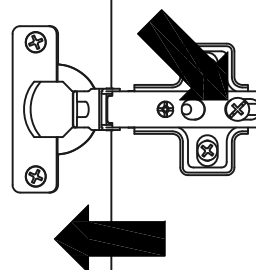

STEP 22.2.2. IF YOU NEED TO SLIDE THE DOOR FORWARD, PULL THE DOOR SLIGHTLY.

AFTER

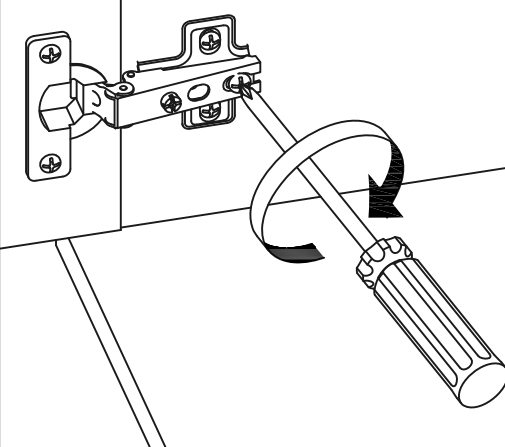
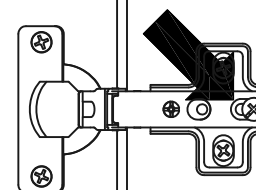

STEP 22.3. TIGHTEN THE BACK CENTER SCREW.

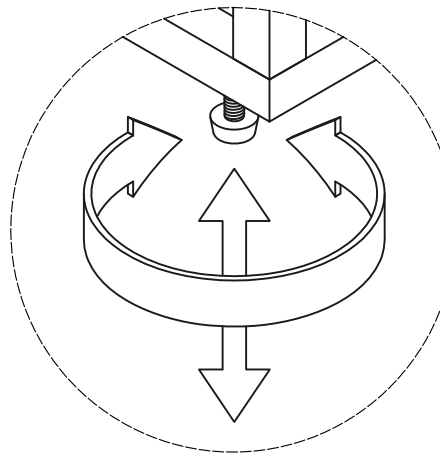
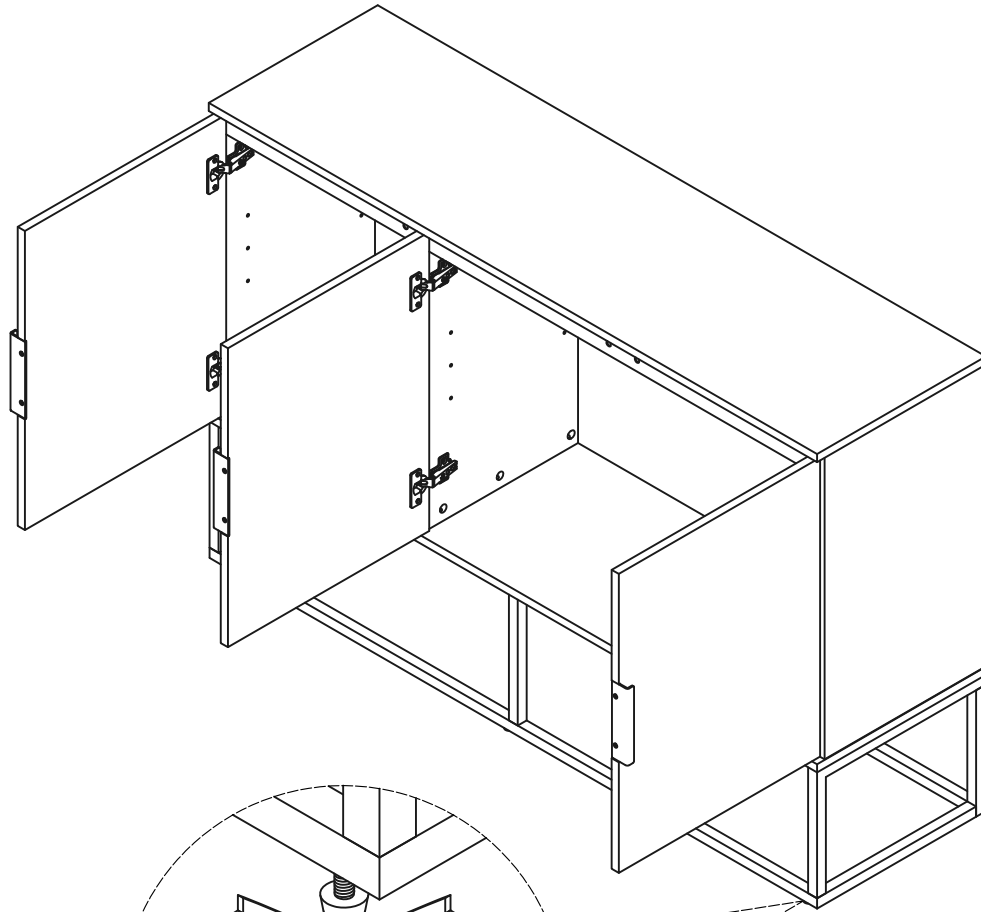

STEP 23 ADJUST THE ADJUSTER THAT HAS ALREADY BEEN ASSEMBLED TO THE LEGS TO STABILIZE YOUR UNIT.

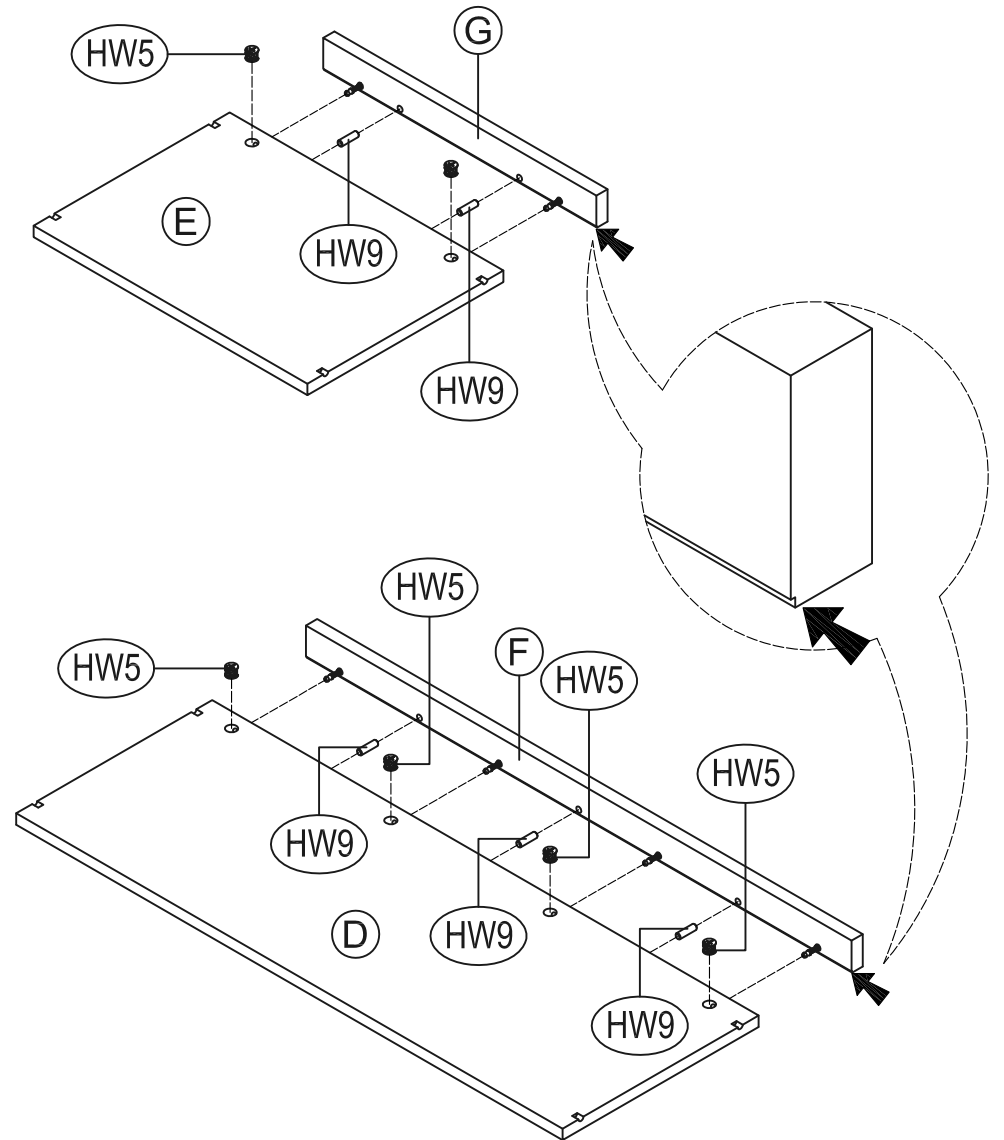

STEP 24 ATTACH RAIL ADJUSTABLE SHELF 1 (F) TO ADJUSTABLE SHELF 1 (D) USING CAMLOCKS (HW5) AND DOWELS (HW9). ATTACH RAIL ADJUSTABLE SHELF 2 (G) TO ADJUSTABLE SHELF 2 (E) USING CAMLOCKS (HW5) AND DOWELS (HW9).

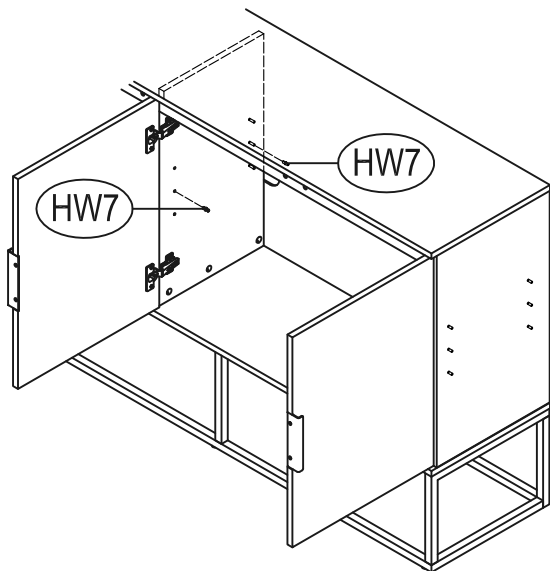

STEP 25 INSERT SHELF SUPPORT PINS (HW7) INTO LEFT PANEL AT DESIRED LEVEL.

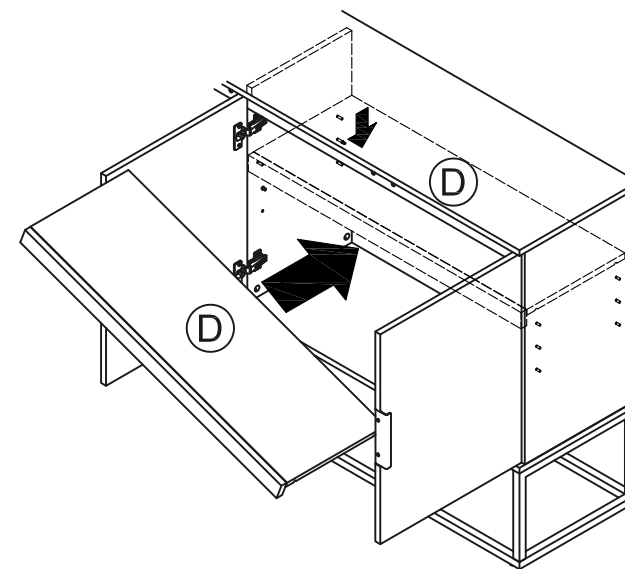

STEP 26 PLACE THE LEFT SIDE OF THE ADJUSTABLE SHELF (D) INTO POSITION.

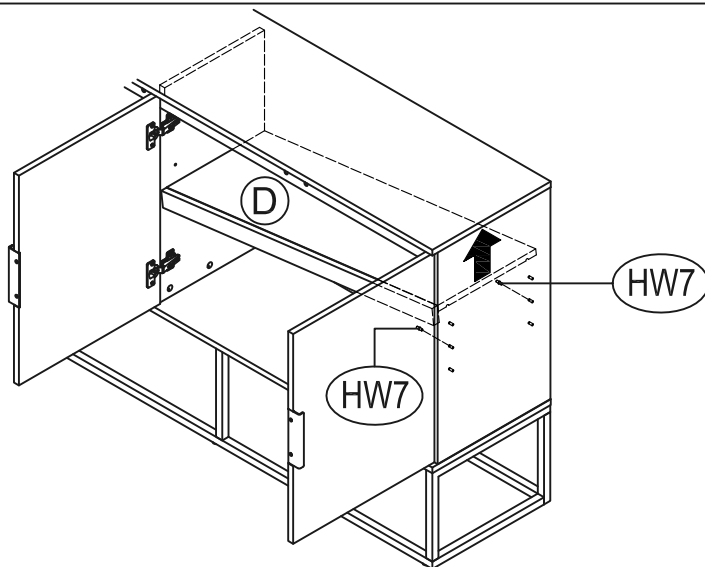

STEP 27 HOLDING IT ON THE RIGHT SIDE OF THE SIDE PANEL HIGHER THAN THE DESIRED LEVEL, INSERT THE REST SHELF SUPPORT PINS (HW7) INTO RIGHT PANEL AT DESIRED LEVEL.

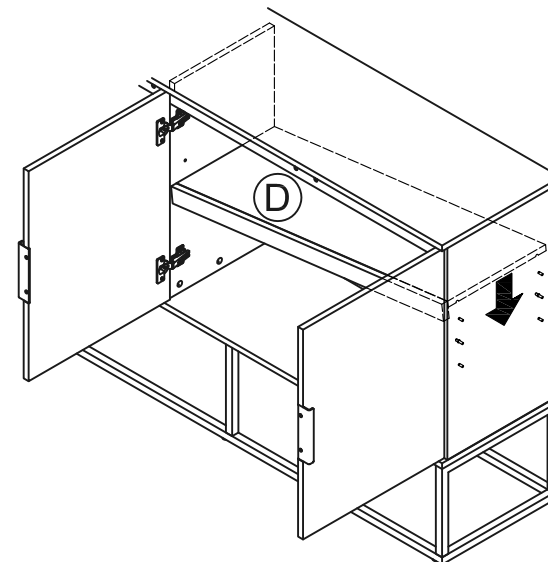

STEP 28 PLACE THE RIGHT SIDE OF THE ADJUSTABLE SHELF (D) INTO POSITION. DO THE SAME STEP TO THE NEXT SHELF.