

## NOTICE

- \* Please make sure that you have all parts indicated and they are in good condition before you begin assembly of this item. Refer to part list and hardware list below for guidance.
- \* This item should be assembled on a soft surface to prevent scratching the finish during assembly.
- \* This item may require periodic tightening.
- \* If you are having difficulty, our friendly Customer Care team is always here to help. Please email [customersupport@safavieh.com](mailto:customersupport@safavieh.com)







## PREPARATION

- \* Before beginning assembly of product, make sure all parts are present. Compare parts with part contents list and hardware contents list.
- \* If any part is missing or damaged, do not attempt to assemble the product.
- \* Estimated Assembly Time: 10 minutes.
- \* Tools Required for Assembly (included): Wrench.

## CARE AND MAINTENANCE

- \* Never use abrasive or acid-based cleaners on the shelf rack.
- \* Clean shelves and rods with a solution of mild detergent and water. Use a soft cloth or sponge to wipe parts. Rinse and dry thoroughly.
- \* Keep surfaces dry and clean for a longer lasting finish.

### Part List and Hardware List

PIECE	DESCRIPTION	PICTURE	QUANTITY
A	Wire Shelf		1X
B	Y-Shaped Pole		1X
C	Upper Pole		2X
D	Hanging Rod		1X
E	Plastic Clip		12X
F	Caster		4X
G	Wrench		1X

# SAFAVIEH FURNITURE

Item ID: HAC1020A

Product Size: 35.4"Wx13.8"Dx65"H

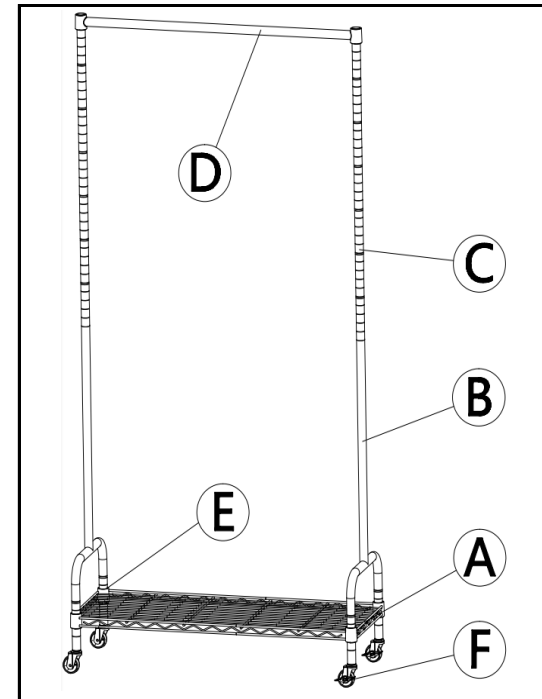

 **WARNING** 

Weight Capacity: 110 LBS  
Warning: Do not stand on Table.

## PREPARATION

- \* Before beginning assembly of product, make sure all parts are present. Compare parts with part contents list and hardware contents list.
- \* If any part is missing or damaged, do not attempt to assemble the product.
- \* Estimated Assembly Time: 10 minutes.
- \* Tools Required for Assembly (included): Wrench.
- \* If you are having difficulty, our friendly Customer Care team is always here to help. Please email [customersupport@safavieh.com](mailto:customersupport@safavieh.com)

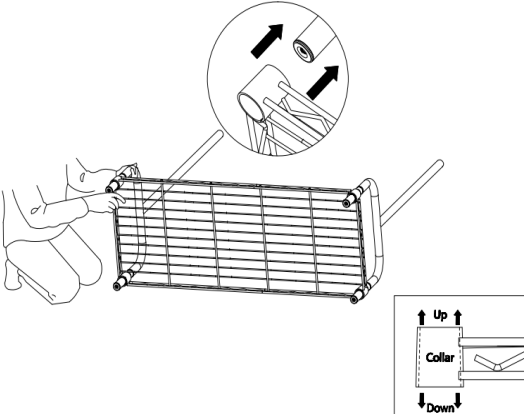
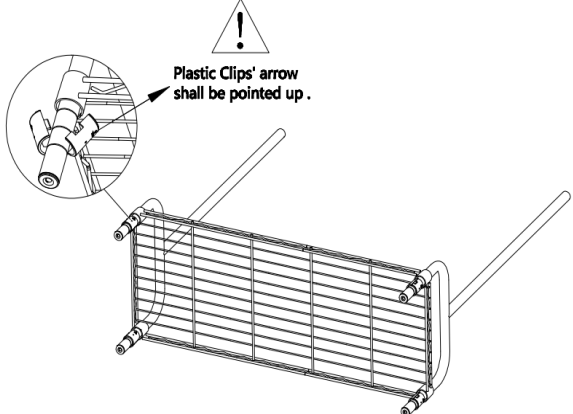
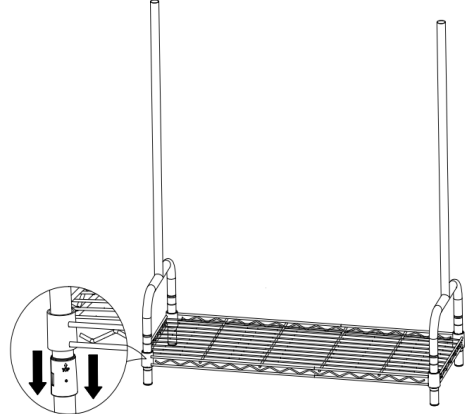
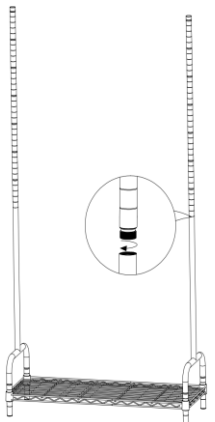
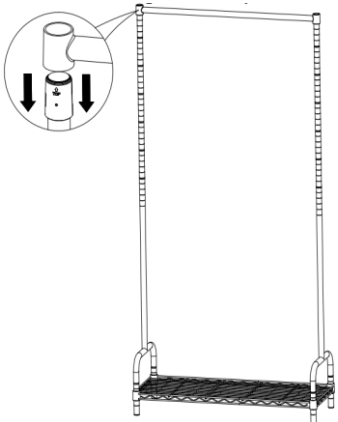
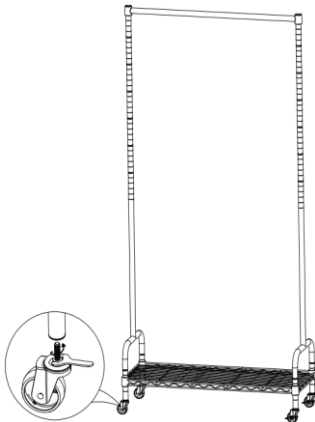
 <p>Up ↑ Collar Down ↓</p>	 <p>! Plastic Clips' arrow shall be pointed up.</p>	
<p><b>STEP 1:</b> INSERT Y-SHAPED POLES(B) INTO FOUR COLLARS OF WIRE SHELF(A) PICTURED ABOVE.</p>	<p><b>STEP 2:</b> SNAP PLASTIC CLIPS(E) ONTO SAME GROOVES OF POLES. MAKE SURE THAT PLASTIC CLIPS ARE UNDER THE WIRE SHELF.</p>	<p><b>STEP 3:</b> SET THE RACK UPRIGHT. PRESS THE WIRE SHELF FIRMLY DOWN ONTO PLASTIC CLIPS UNTIL THERE IS SNUG FIT.</p>
		
<p><b>STEP 4:</b> SCREW UPPER POLES(C) INTO Y-SHAPED POLES BY SCREW CONNECTORS ASSEMBLED ON UPPER POLES.</p>	<p><b>STEP 5:</b> SNAP PLASTIC CLIPS ONTO TOP GROOVES OF POLES AND ASSEMBLE THE HANGING ROD(D).</p>	<p><b>STEP 6:</b> SCREW CASTERS(F) INTO BOTTOM OF EACH Y-SHAPED POLE BY WRENCH(G).</p>