

NOTICE

- * Please make sure that you have all parts indicated and they are in good condition before you begin assembly of this item. Refer to part list and hardware list below for guidance.
- * This item should be assembled on a soft surface to prevent scratching the finish during assembly.
- * This item may require periodic tightening.
- * If you are having difficulty, our friendly Customer Care team is always here to help. Please email customersupport@safavieh.com







PREPARATION

- * Before beginning assembly of product, make sure all parts are present. Compare parts with part contents list and hardware contents list.
- * If any part is missing or damaged, do not attempt to assemble the product.
- * Estimated Assembly Time: 10 minutes.
- * Tools Required for Assembly (included): No.

CARE AND MAINTENANCE

- *Never use abrasive or acid-based cleaners on the shelf rack.
- *Clean shelves and rods with a solution of mild detergent and water. Use a soft cloth or sponge to wipe parts. Rinse and dry thoroughly.
- *Keep surfaces dry and clean for a longer lasting finish.

Part List and Hardware List

PIECE	DESCRIPTION	PICTURE	QUANTITY
A	Wire Shelf		4X
B	Lower Pole		4X
C	Upper Pole		4X
D	Plastic Clip		32X
E	Leveling Feet		4X
F	PP Mat		4X

SAFAVIEH FURNITURE

Item ID: HAC1005A

Product Size: L17.72"xW11.81"xH31.89"

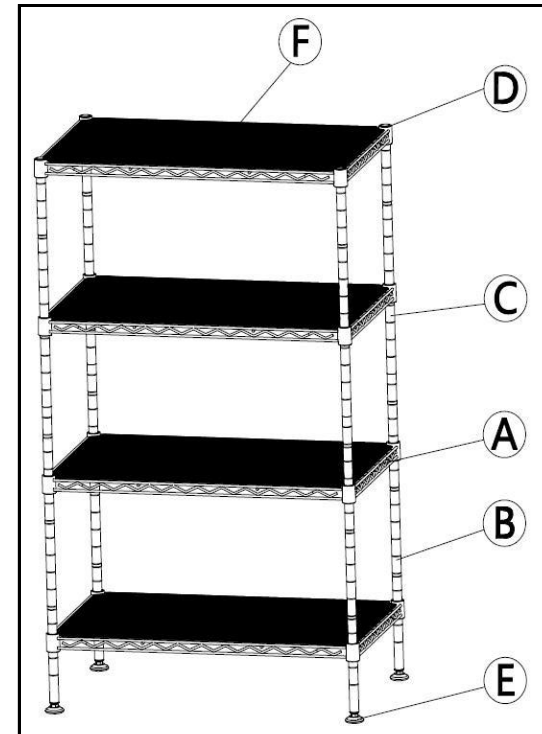

 **WARNING** 

Weight Capacity: 66 LBS
Warning: Do not stand on Table.

PREPARATION

- * Before beginning assembly of product, make sure all parts are present. Compare parts with part contents list and hardware contents list.
- * If any part is missing or damaged, do not attempt to assemble the product.
- * Estimated Assembly Time: 10 minutes.
- * Tools Required for Assembly (included): No.
- * If you are having difficulty, our friendly Customer Care team is always here to help. Please email customersupport@safavieh.com

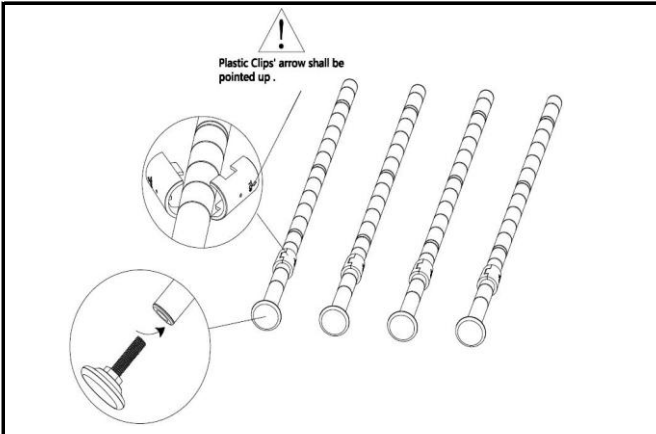

STEP 1: SCREW LEVELING FEET(E) INTO BOTTOM OF EACH LOWER POLE(B). SNAP PLASTIC CLIPS(D) ONTO SAME GROOVES OF LOWER POLES.

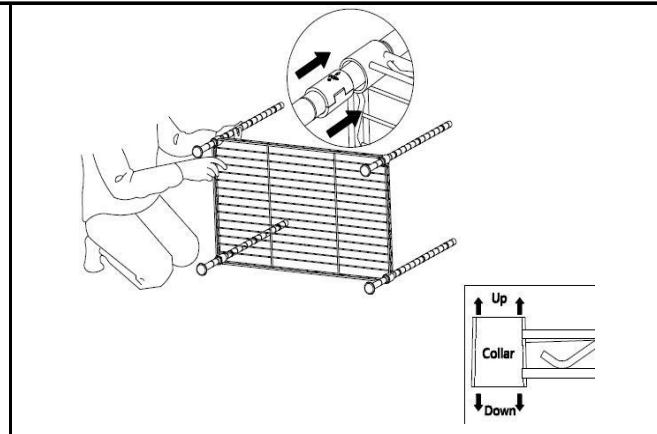

STEP 2: HOLD WIRE SHELF(A) ON ITS SIDE AND SLIDE IT FROM THE TOP OF EACH LOWER POLE DOWN ONTO THE PLASTIC CLIPS.

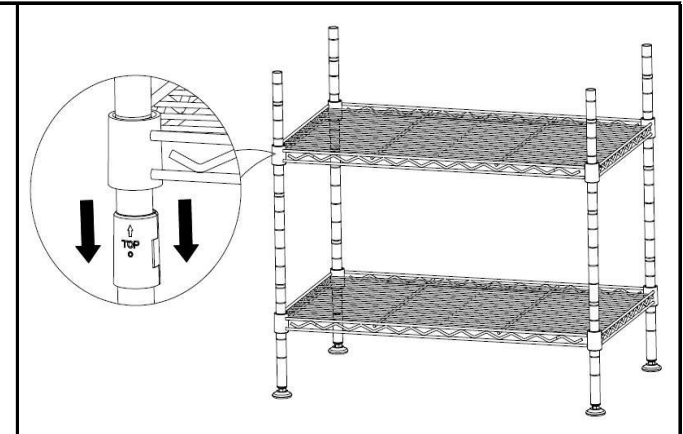

STEP 3: REFER TO STEP 1&2 TO SNAP PLASTIC CLIPS ONTO SAME GROOVES OF LOWER POLES TO ASSEMBLE THE SECOND WIRE SHELF.

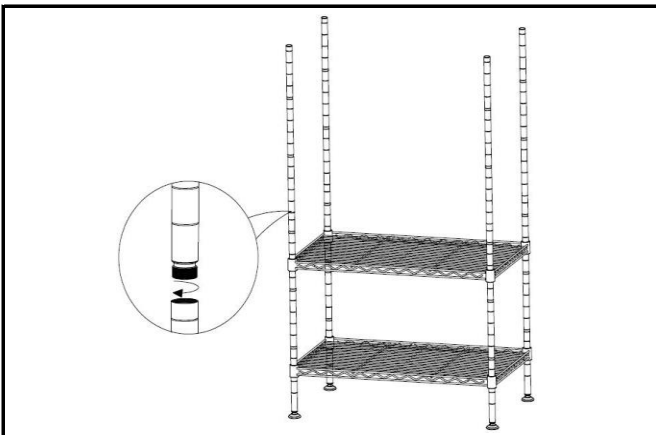

STEP 4: SCREW UPPER POLES(C) INTO LOWER POLES BY SCREW CONNECTORS ASSEMBLED ON UPPER POLES.

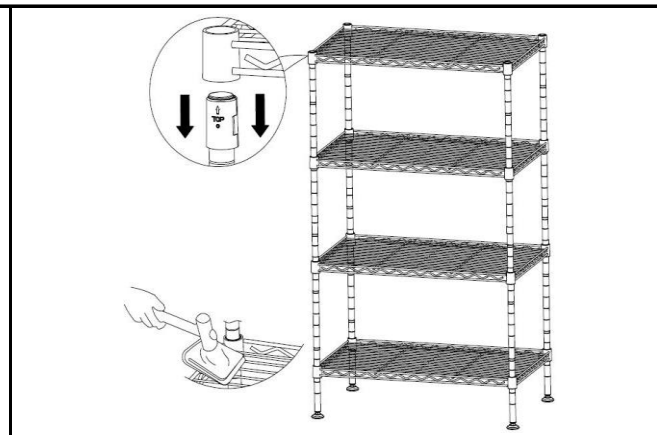

STEP 5: REFER TO STEP 1&2 TO ASSEMBLE THE REMAINING TWO PIECES WIRE SHELVES. PUSHING FIRMLY DOWN ON EACH SHELF AT ITS CORNER OVER PLASTIC CLIPS.

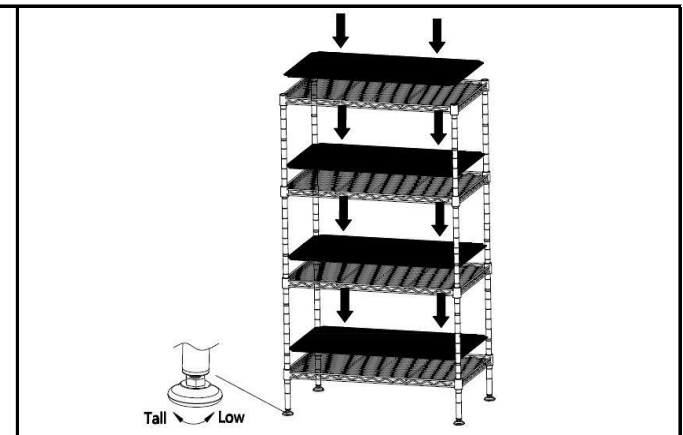

STEP 6: SCREW LEVELING FEET TO ATTAIN PROPER LEVELING. THEN PUT EACH PP MAT(F) ONTO EACH SHELF PICTURED ABOVE.