

## NOTICE

- \* Please make sure that you have all parts indicated and they are in good condition before you begin assembly of this item. Refer to part list and hardware list below for guidance.
- \* This item should be assembled on a soft surface to prevent scratching the finish during assembly.
- \* This item may require periodic tightening.
- \* If you are having difficulty, our friendly Customer Care team is always here to help. Please email [customersupport@safavieh.com](mailto:customersupport@safavieh.com)







## PREPARATION

- \* Before beginning assembly of product, make sure all parts are present. Compare parts with part contents list and hardware contents list.
- \* If any part is missing or damaged, do not attempt to assemble the product.
- \* Estimated Assembly Time: 10 minutes.
- \* Tools Required for Assembly (included): No.

## CARE AND MAINTENANCE

- \* Never use abrasive or acid-based cleaners on the shelf rack.
- \* Clean shelves and rods with a solution of mild detergent and water. Use a soft cloth or sponge to wipe parts. Rinse and dry thoroughly.
- \* Keep surfaces dry and clean for a longer lasting finish.

### Part List and Hardware List

PIECE	DESCRIPTION	PICTURE	QUANTITY
A	Bottom Shelf		1X
B	Wire Shelf		3X
C	Lower Pole		3X
D	Upper Pole		3X
E	Plastic Clip		24X
F	Leveling Feet		4X

# SAFAVIEH FURNITURE

Item ID: HAC1004A

Product Size: 11.8"Wx11.8"Dx31.5"H

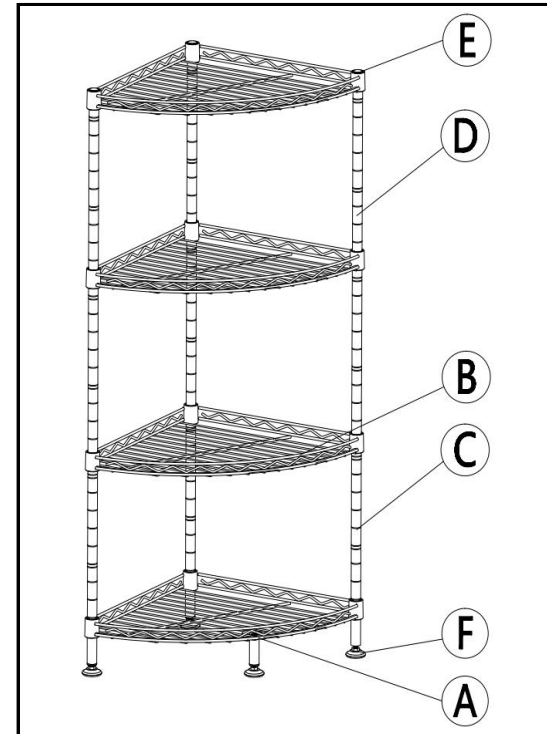

**WARNING**



Weight Capacity: 44 LBS

Warning: Do not stand on Table.

# PREPARATION

- \* Before beginning assembly of product, make sure all parts are present. Compare parts with part contents list and hardware contents list.
- \* If any part is missing or damaged, do not attempt to assemble the product.
- \* Estimated Assembly Time: 10 minutes.
- \* Tools Required for Assembly (included): No.
- \* If you are having difficulty, our friendly Customer Care team is always here to help. Please email [customersupport@safavieh.com](mailto:customersupport@safavieh.com)

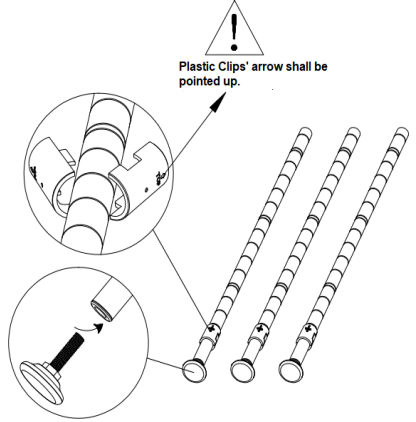
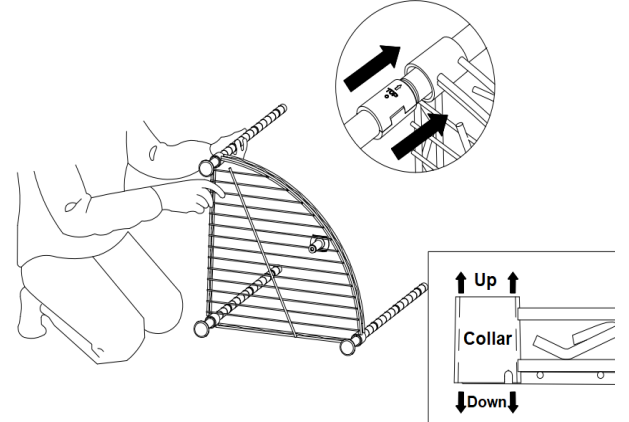
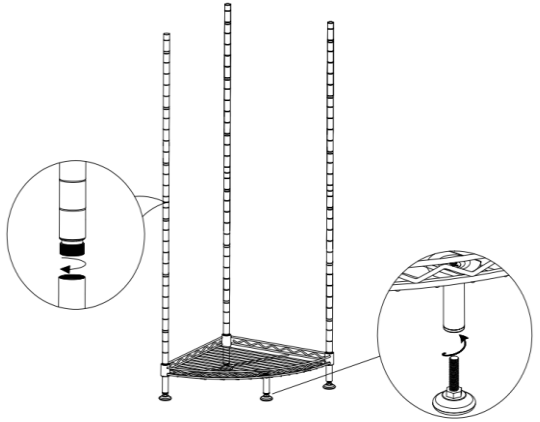
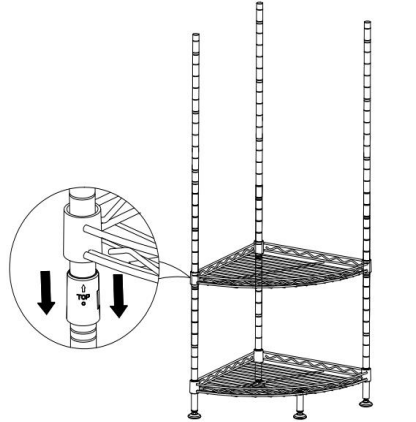
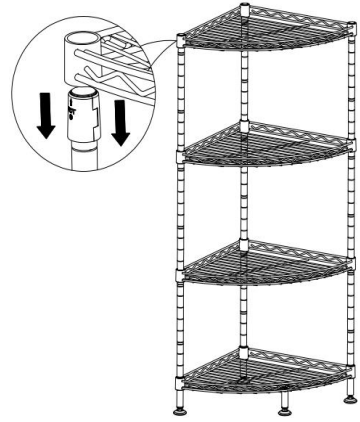
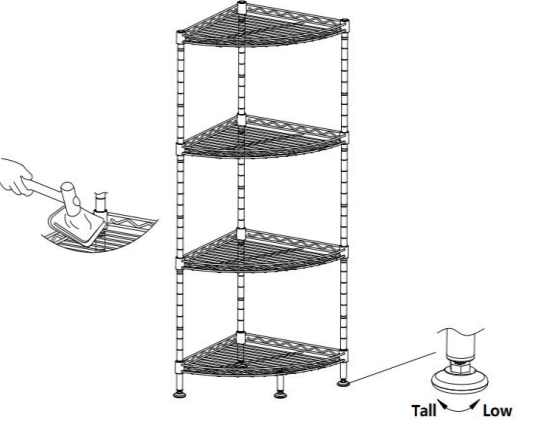
		
<p><b>STEP 1:</b> SCREW LEVELING FEET(F) INTO BOTTOM OF LOWER POLES(C). SNAP PLASTIC CLIPS(E) ONTO SAME SPECIFIED GROOVES OF POLES PICTURED ABOVE.</p>	<p><b>STEP 2:</b> HOLD BOTTOM SHELF (A) ON ITS SIDE AND SLIDE IT FROM THE TOP OF EACH LOWER POLE DOWN ONTO THE PLASTIC CLIPS.</p>	<p><b>STEP 3:</b> SCREW UPPER POLES(D) INTO LOWER POLES BY SCREW CONNECTORS. ASSEMBLE THE REMAINING LEVELING FEET UNDER THE BOTTOM SHELF.</p>
		
<p><b>STEP 4:</b> SNAP PLASTIC CLIPS ON THE SAME GROOVES OF EACH POLE AND ASSEMBLE THE FIRST WIRE SHELF(B).</p>	<p><b>STEP 5:</b> REFER TO STEP 4 TO ASSEMBLE THE REMAINING TWO PIECES WIRE SHELVES PICTURED ABOVE.</p>	<p><b>STEP 6:</b> PUSHING FIRMLY DOWN ON EACH SHELF AT ITS CORNER OVER PLASTIC CLIPS AND SCREW LEVELING FEET TO ATTAIN PROPER LEVELING.</p>