

## CARE AND MAINTENANCE

~~For cleaning of the frame, use a mild, soapy water, then dry the surface immediately with a clean, soft cloth. For glass, dust with a soft, dry cloth. Do not use abrasive cleaner.~~



To use of washing powder or any other substances containing abrasives may scratch the glass.

## NOTICE

\* Please make sure that you have all parts indicated before you begin assembly of this item

\* This item should be assembled on a soft surface to prevent scratching the finish during assembly

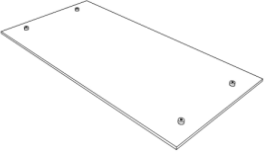
## Part List and Hardware List

PIECE	DESCRIPTION	PICTURE	QUANTITY
A	Stainless Steel Frame		1X
B	Clear Glass Top		1X
HW1	Hexagon Socket Screws 6*0.5*10mm		5X
HW2	Allen Key		1X

# SAFAVIEH

C O U T U R E

**FOX9078A**

**DIMENSIONS: 47.24"L x 23.62"W x 30.71"H**



WEIGHT CAPACITY: 150 LBS

**WARNING: DO NOT STAND ON TABLE**

**WARNING: DO NOT OVER TORQUE BOLTS/SCREWS**

**The hardware is hang on the side leg**



## PREPARATION

Before beginning assembly of product, make sure all parts are present. Compare parts with package contents list and hardware contents list.

If any part is missing or damaged, do not attempt to assemble the product.

Estimated Assembly Time: 10 minutes.

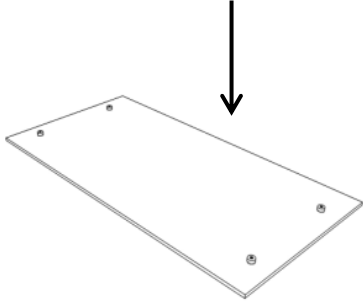
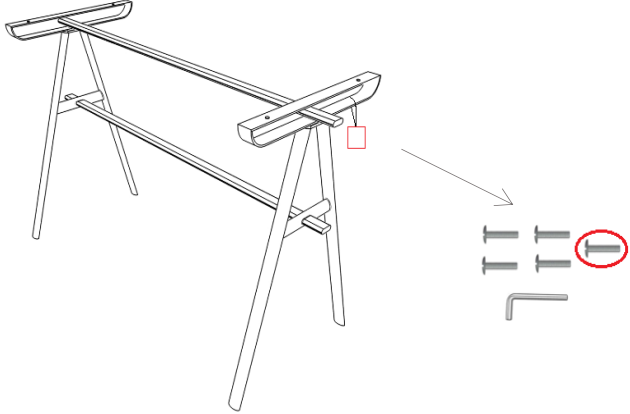
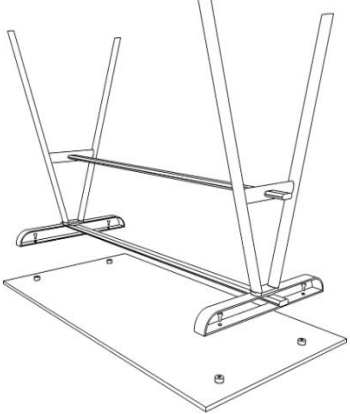
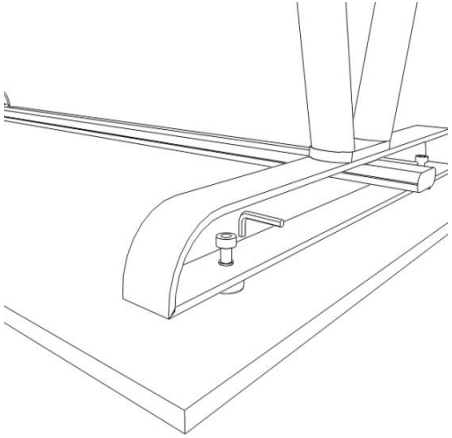
Tools Required for Assembly (included): Allen Key

		
<p><b>STEP1</b> PUT CLEAR GLASS TOP(B) FACE DOWN AS PICTURE ON A CLEAN, NON-MARRING SURFACE</p>	<p><b>STEP2</b> TAKE OUT THE HARDWARE</p>	<p><b>STEP3</b> PLACE AND POSITION THE STAINLESS STEEL FRAME(A) ONTO THE CLEAR GLASS TOP(B)</p>
		
<p><b>STEP4</b> AFFIX THEM TOGETHER BY USING 4PCS OF BOLTS WITH ALLEN KEY, THE REMAINING 1 BOLT IS SPARE PART</p>	<p><b>STEP5</b> TURN THE TABLE RIGHT SIDE UP. CHECK FOR STABILITY. ENSURE ALL BOLTS ARE FULLY LOCKED AND SECURED INTO POSITION. YOUR TABLE IS NOW READY FOR USE</p>	
<p><b>The hardware is hang on the side leg</b></p>		