

CARE AND MAINTENANCE

Spot clean using a mild water-free solvent. Only a professional cleaner should undertake a complete overall cleaning.

The use of steam or water-based cleaners may cause excessive shrinking or staining.











NOTICE

* Please make sure that you have all parts indicated before you begin assembly of this item

* This item should be assembled on a soft surface to prevent scratching the finish during assembly

* This item may require periodic tightening

Part List and Hardware List

PIECE	DESCRIPTION	PICTURE	QUANTITY
A	Backrest		1X
B	Chair Leg		4X
C	Footrest		1X
D	Apron with swivel plate		1X
E	Cushion seat		1X
1	JCBC Screw M6x30mm		8X
2	JCBC Screw M6x45mm		14X
3	Spring Washer M6x10mm		18X
4	Flat Washer M6x13mm		4X
5	Flat Washer M6x16mm		18X
6	Allen Key Small M4		1X

 **SAFAVIEH**
FURNITURE

Model# FOX7008

Product Dimensions:27.37" W x 24.25" D x 48.25" H

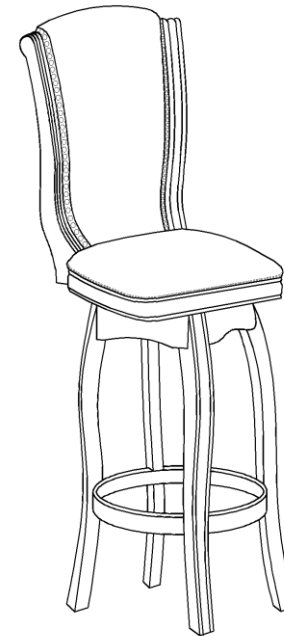

PREPARATION

Before beginning assembly of product, make sure all parts are present. Compare parts with package contents list and hardware contents list.

If any part is missing or damaged, do not attempt to assemble the product.

Estimated Assembly Time: 10 minutes.

Tools Required for Assembly (included): Allen Key

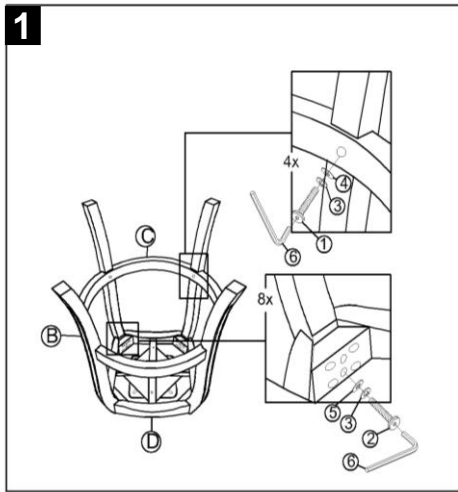

Step 1
Attach front leg-1 (B) front leg-2 (C) to chair (A) using Allen bolt L (H1), flat washer (H4), and Spring washer (H3). Tighten with allen key (H5)

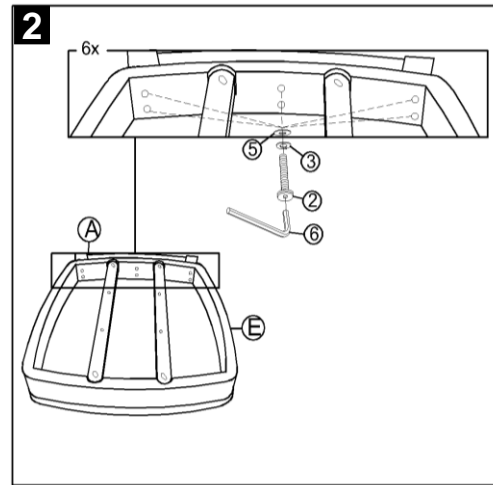

Step 2
Attach rear legs (D) to chair (A) using allen bolt (H2) flat washer (H4), and Spring washer (H3). Tighten with allen key (H5)

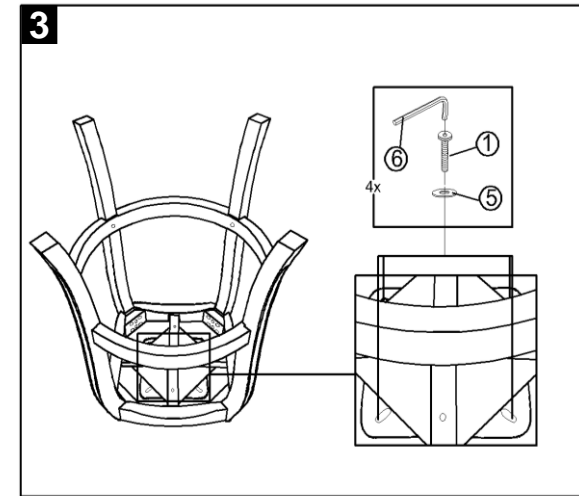

Step 3
Stick the bottom fabric to the chair.
Stand chair (A) upright. Assembly is complete.