







## CARE AND MAINTENANCE

Wipe clean with a soft, dry cloth. The seat board can be cleaned with a mild cleaner. Test the cleaning method on a hidden area before using them over the entire area.

## NOTICE

- \* Please make sure that you have all parts indicated before you begin assembly of this item.
- \* This item should be assembled on a soft surface to prevent scratching the finished product during assembly.
- \* This item may require periodic tightening.
- \* Do not tighten bolts until completely assembled.

## Part List and Hardware List

Piece	Description	Picture	Quantity
A	CABINET		1 X
B	SHELF		1 X
C	LEG		4 X
H1	BOLT 1/4"* 2"		8 X
H2	ALLEN KEY 4mm		1 X
H3	BRACKET 25*25mm		4 X
H4	WOODEN SCREW M4*15mm		8 X

 **SAFAVIEH**  
FURNITURE

Model# :FOX6275

Product Dimensions: 24"W\*18"D\*26"H.

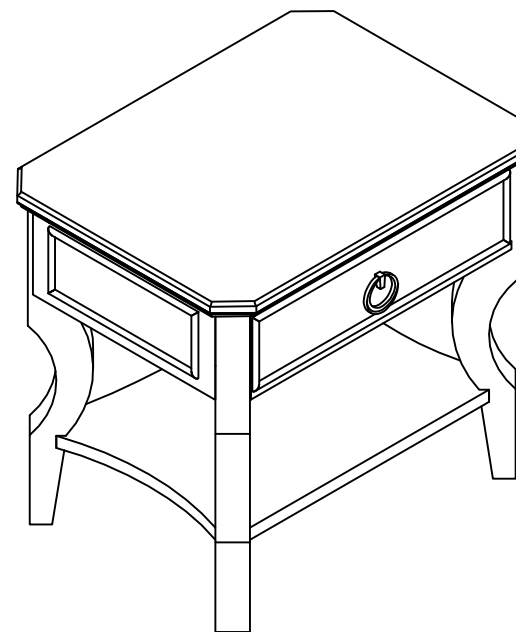

## PREPARATION

Before beginning assembly of product, make sure all parts are present. Compare parts with package contents list and hardware contents list. If any part is missing or damaged, do not attempt to assemble the product.

Estimated Assembly Time:10 minutes.

Tools Required for Assembly (included):Allen key.

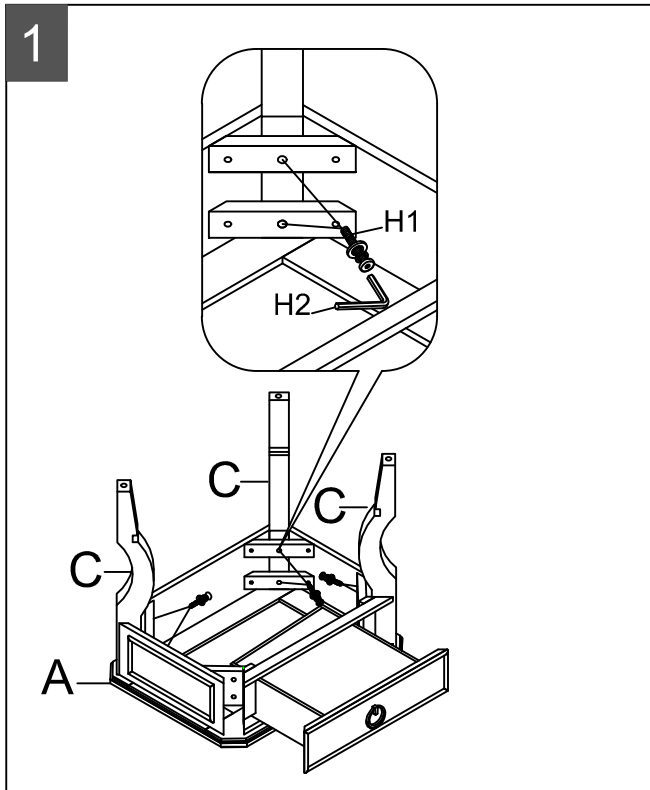

Step 1 :  
Attach 3 legs (C) first, screw with cabinet (A)  
by using Allen key (H2) to lock with 6\*bolts (H1)

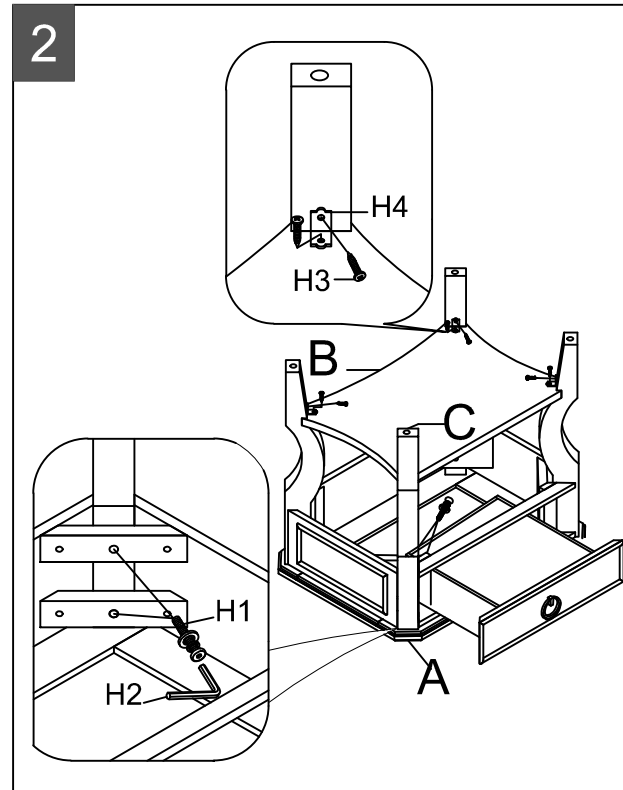

Step 2 :  
Attach the shelf (B) with the assembled 3 legs  
(C), then attach the last one leg (C) to the  
cabinet (A), using Allen key (H2) to lock with  
2\*bolts (H1).  
Screwing 4\*brackets (H3) by 8\*wooden  
screws (H4).

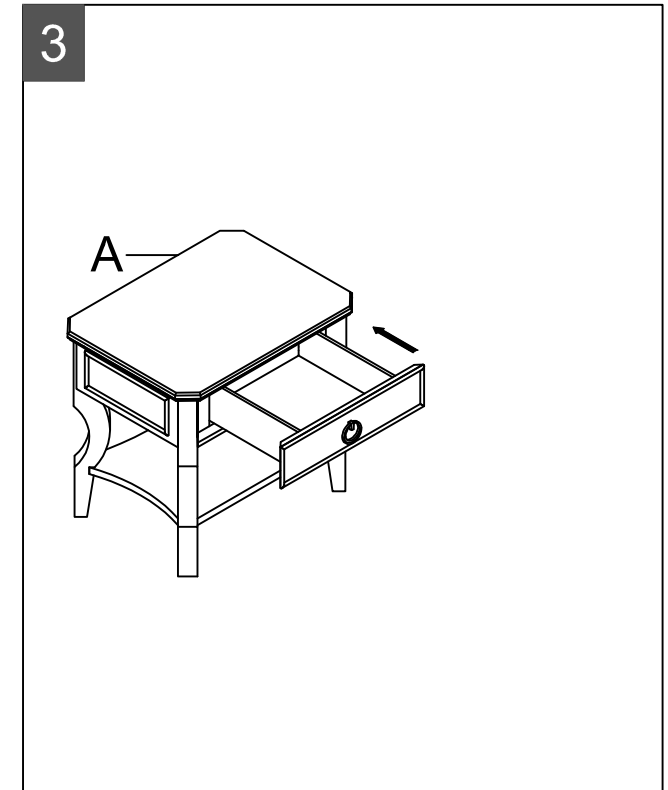

Step 3 :  
Push the drawer close, assembly is completed.