

CARE AND MAINTENANCE

Spot clean using a mild water-free solvent. Only a professional cleaner should undertake a complete overall cleaning.
The use of steam or water-based cleaners may cause excessive shrinking or staining.

NOTICE













- * Please make sure that you have all parts indicated before you begin assembly of this item.
- * This item should be assembled on a soft surface to prevent scratching the finish during assembly.
- * This item may require periodic tightening.



Model# DSK5011

Product Dimensions: 42" W x 20" D x 30" H

Part List and Hardware List

PIECE	DESCRIPTION	PICTURE	QUANTITY
A	TOP PANEL		1X
B	LEFT FRONT LEG		1X
C	RIGHT FRONT LEG		1X
D	LEFT BACK LEG		1X
E	RIGHT BACK LEG		1X
F	SIDE RAIL		2X
G	SIDE STRETCHER		2X
H	BACK STRETCHER		1X
1	40mm HEAD CAP BOLT	M6x40mm 	8X
2	15mm HEAD CAP BOLT	M6x15mm 	10X
3	SPRING WASHER		10X
4	ALLEN KEY		1X

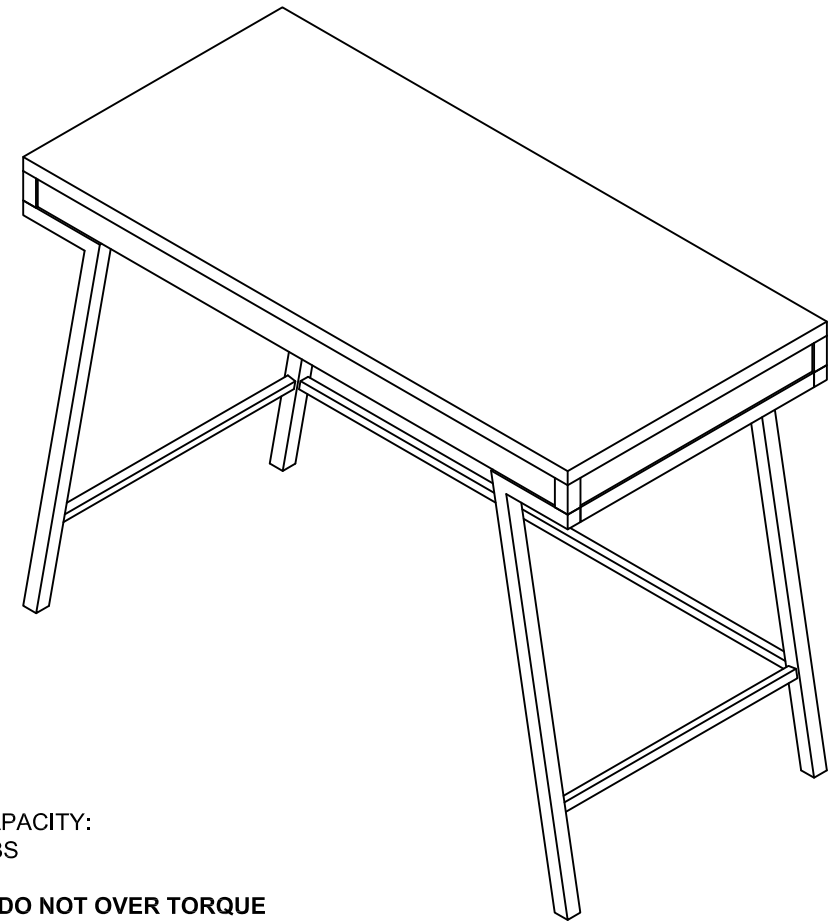

WEIGHT CAPACITY:
TOP: 100 LBS

**WARNING: DO NOT OVER TORQUE
BOLTS/SCREWS**

PREPARATION

Before beginning assembly of product, make sure all parts are present. Compare parts with package contents list and hardware contents list.

If any part is missing or damaged, do not attempt to assemble the product.

Estimated Assembly Time: 30 minutes.

Tools Required for Assembly : Phillips Screwdriver

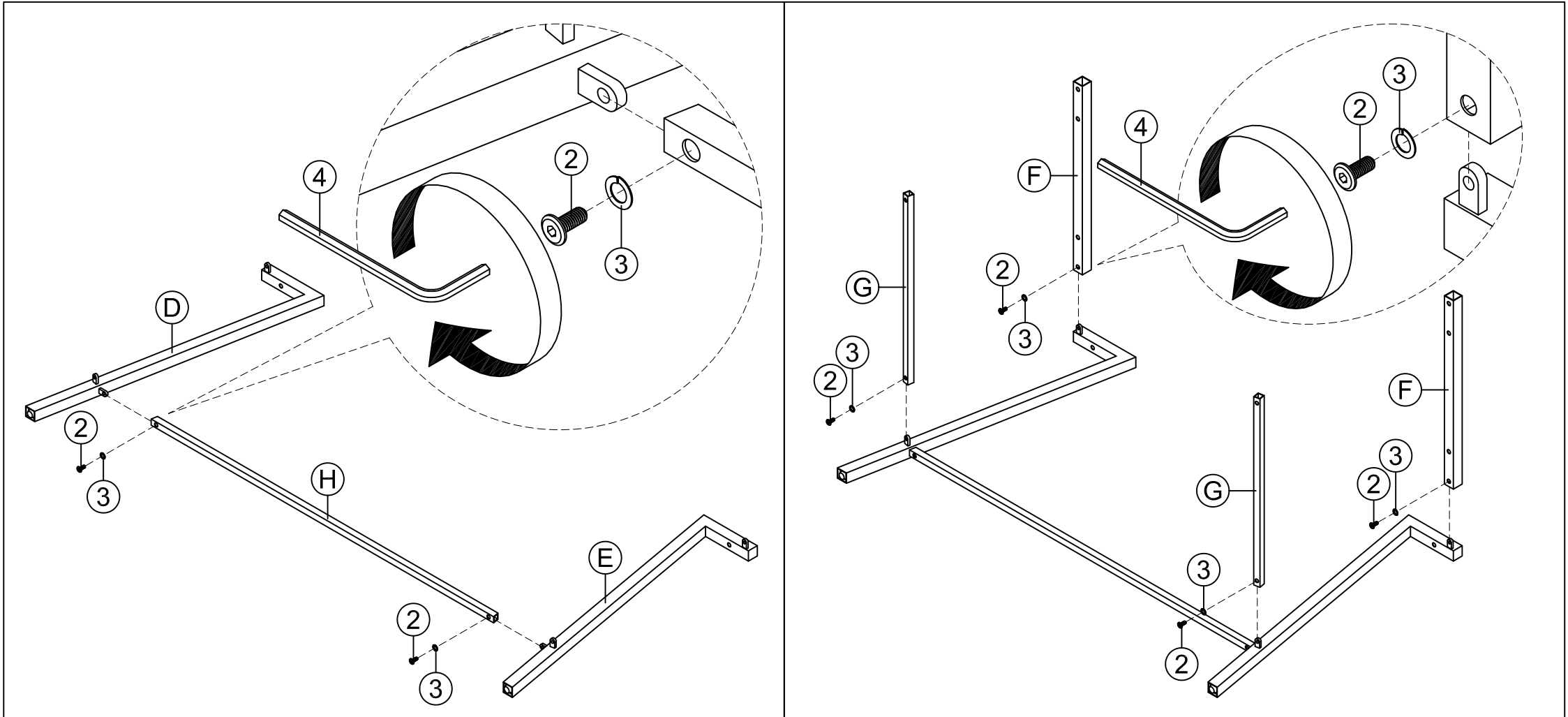

STEP 1 ATTACH LEFT AND RIGHT BACK LEGS TO BACK STRETCHER USING 15mm HEAD CAP BOLTS AND SPRING WASHERS.

NOTE: TURN BOLTS USING ALLEN KEY ONLY HALFWAY THIS TIME.

STEP 2 ATTACH SIDE RAILS AND STRETCHERS TO UNIT USING 15mm HEAD CAP BOLTS AND SPRING WASHERS.

NOTE: TURN BOLTS USING ALLEN KEY ONLY HALFWAY THIS TIME.

PREPARATION

Before beginning assembly of product, make sure all parts are present. Compare parts with package contents list and hardware contents list.

If any part is missing or damaged, do not attempt to assemble the product.

Estimated Assembly Time: 30 minutes.

Tools Required for Assembly : Phillips Screwdriver

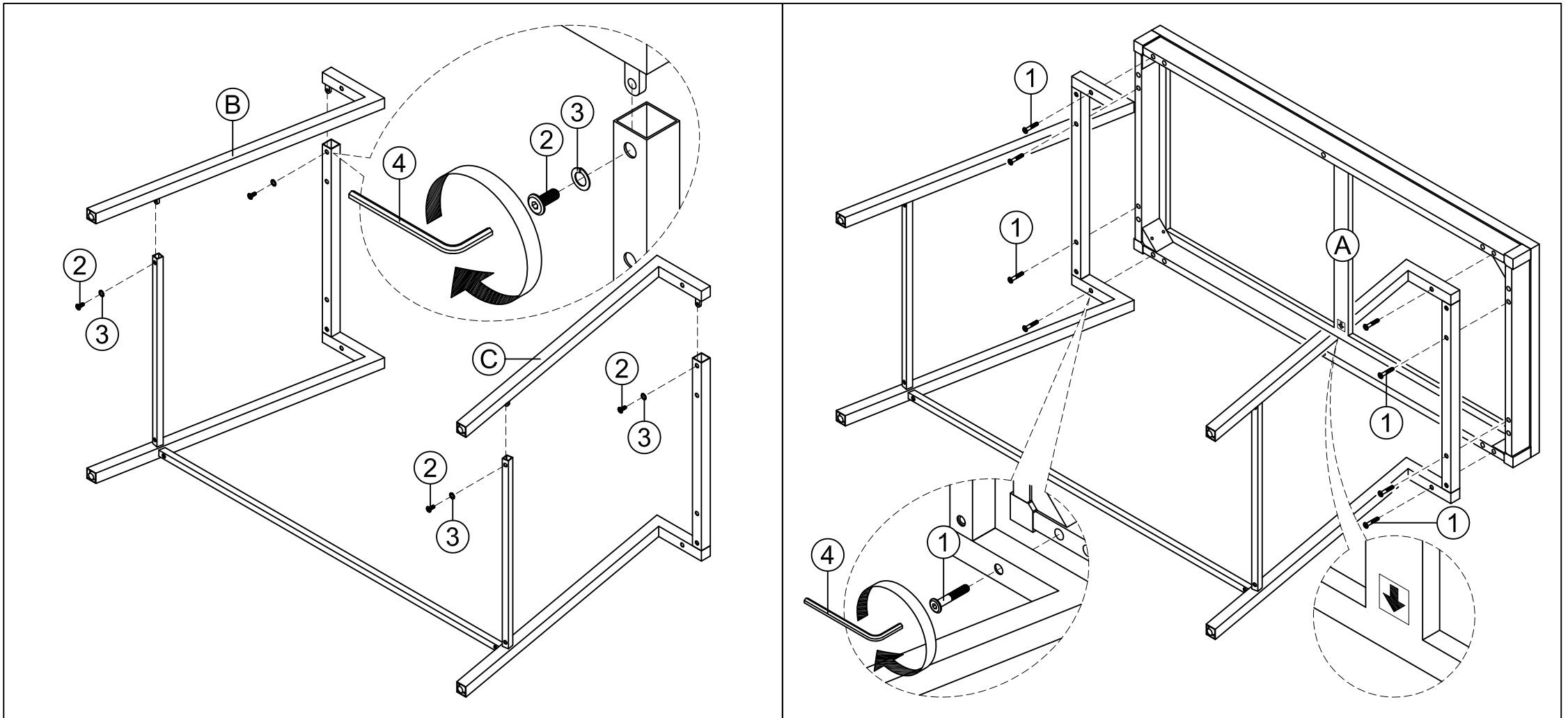

STEP 3 ATTACH LEFT AND RIGHT FRONT LEGS TO UNIT USING 15mm HEAD CAP BOLTS AND SPRING WASHERS.

NOTE: TURN BOLTS USING ALLEN KEY ONLY HALFWAY THIS TIME.

STEP 4 ATTACH TOP PANEL TO UNIT USING 40mm HEAD CAP BOLTS. TIGHTEN BOLTS USING ALLEN KEY.

NOTE: PAY ATTENTION TO THE POSITION OF THE ARROW LABEL IN THE TOP PANEL.

PREPARATION

Before beginning assembly of product, make sure all parts are present. Compare parts with package contents list and hardware contents list.

If any part is missing or damaged, do not attempt to assemble the product.

Estimated Assembly Time: 30 minutes.

Tools Required for Assembly : Phillips Screwdriver

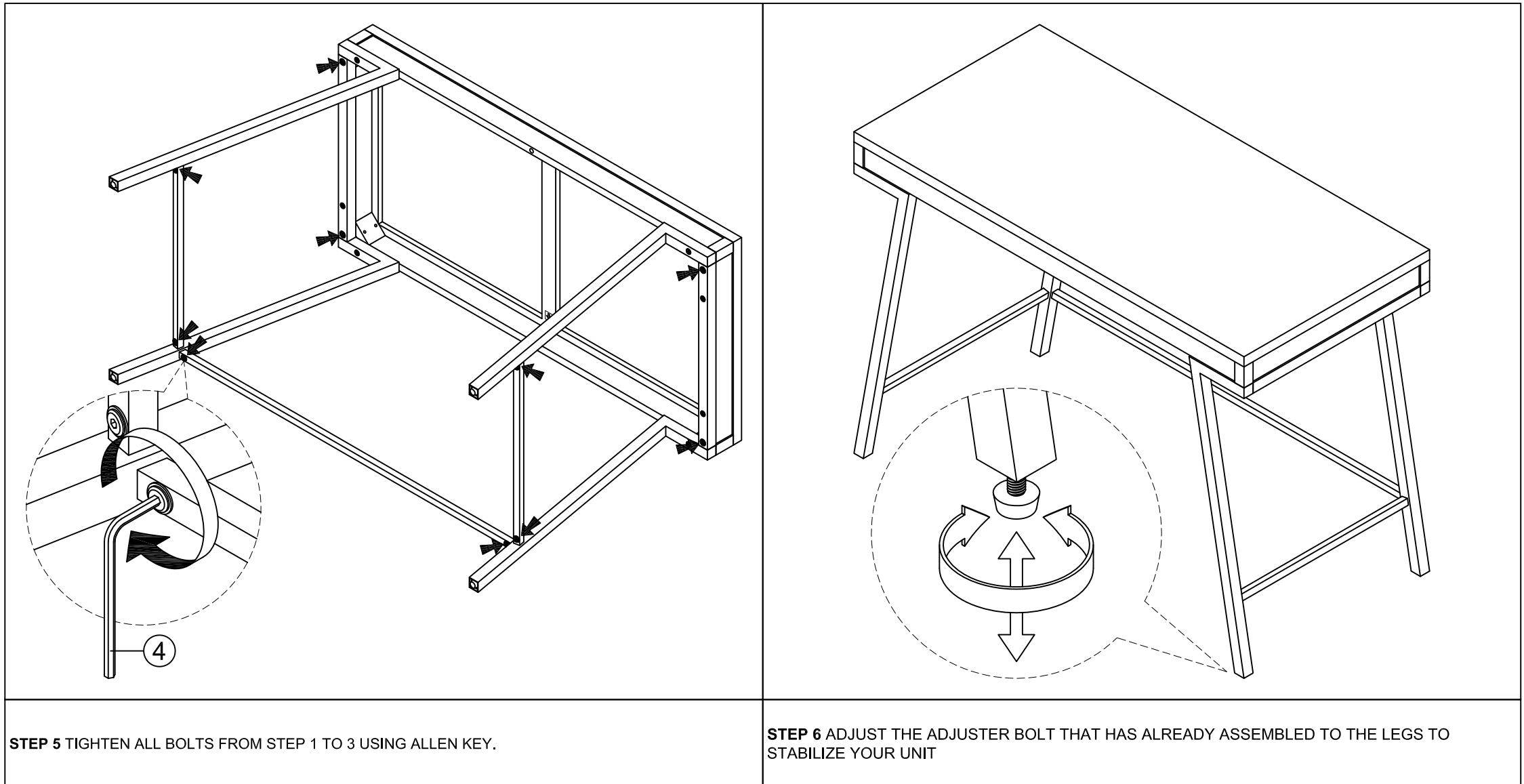

STEP 5 TIGHTEN ALL BOLTS FROM STEP 1 TO 3 USING ALLEN KEY.

STEP 6 ADJUST THE ADJUSTER BOLT THAT HAS ALREADY ASSEMBLED TO THE LEGS TO STABILIZE YOUR UNIT