















CARE AND MAINTENANCE

Spot clean using a mild water-free solvent. Only a professional cleaner should undertake a complete overall cleaning.
The use of steam or water-based cleaners may cause excessive shrinking or staining.

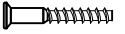
NOTICE

- * Please make sure that you have all parts indicated before you begin assembly of this item.
- * This item should be assembled on a soft surface to prevent scratching the finish during assembly.
- * This item may require periodic tightening.

Part List and Hardware List

PIECE	DESCRIPTION	PICTURE	QUANTITY
A	TOP PANEL		1X
B	FRONT LEG		2X
C	LEFT BACK LEG		1X
D	RIGHT BACK LEG		1X
E	TOP SUPPORT		2X
F	UPPER SIDE STRETCHER		2X
G	LOWER SIDE STRETCHER		2X
H	BACK STRETCHER		2X
1	90mm ASSEMBLY SCREW	M7x90mm 	4X
2	50mm ASSEMBLY SCREW	M7x50mm 	4X
3	50mm HEAD CAP BOLT	M6x50mm 	12X
4	15mm HEAD CAP BOLT	M6x15mm 	4X
5	SPRING WASHER		12X
6	FLAT WASHER		12X
7	ALLEN KEY		1X

 **SAFAVIEH**
FURNITURE

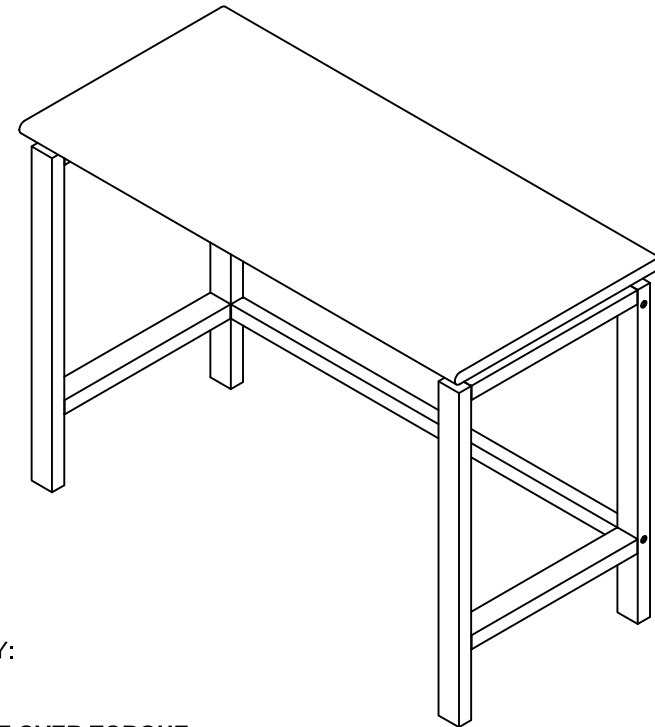

Model# DSK5007

Product Dimensions: 42" W x 20" D x 30" H



WEIGHT CAPACITY:
TOP: 100 LBS

**WARNING: DO NOT OVER TORQUE
BOLTS/SCREWS**

PIECE	DESCRIPTION	PICTURE	QUANTITY
8	CAMBOLT		8X
9	CAMLOCK		8X
10	DOWEL		20X

PREPARATION

Before beginning assembly of product, make sure all parts are present. Compare parts with package contents list and hardware contents list.

If any part is missing or damaged, do not attempt to assemble the product.

Estimated Assembly Time: 30 minutes.

Tools Required for Assembly : Phillips Screwdriver

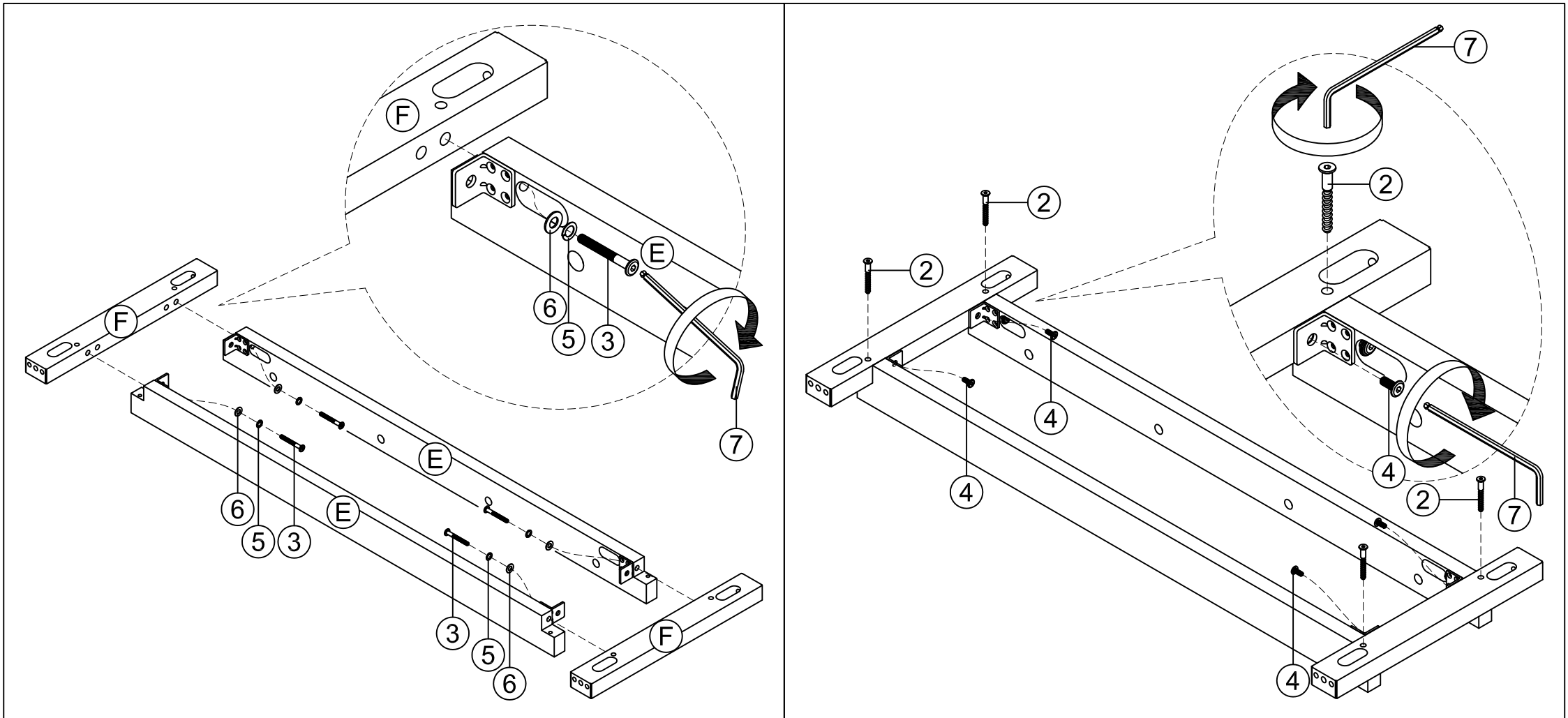

STEP 1 ATTACH TOP SUPPORTS TO UPPER SIDE STRETCHERS USING 50mm HEAD CAP BOLTS, SPRING WASHERS AND FLAT WASHERS.
NOTE: TURN BOLTS USING ALLEN KEY ONLY HALFWAY THIS TIME.

STEP 2 ATTACH 50mm ASSEMBLY SCREWS AND 15mm HEAD CAP BOLTS TO UNIT TO STRENGTHEN ITS CONSTRUCTION.
NOTE: TURN SCREWS AND BOLTS USING ALLEN KEY ONLY HALFWAY THIS TIME.

PREPARATION

Before beginning assembly of product, make sure all parts are present. Compare parts with package contents list and hardware contents list.

If any part is missing or damaged, do not attempt to assemble the product.

Estimated Assembly Time: 30 minutes.

Tools Required for Assembly : Phillips Screwdriver

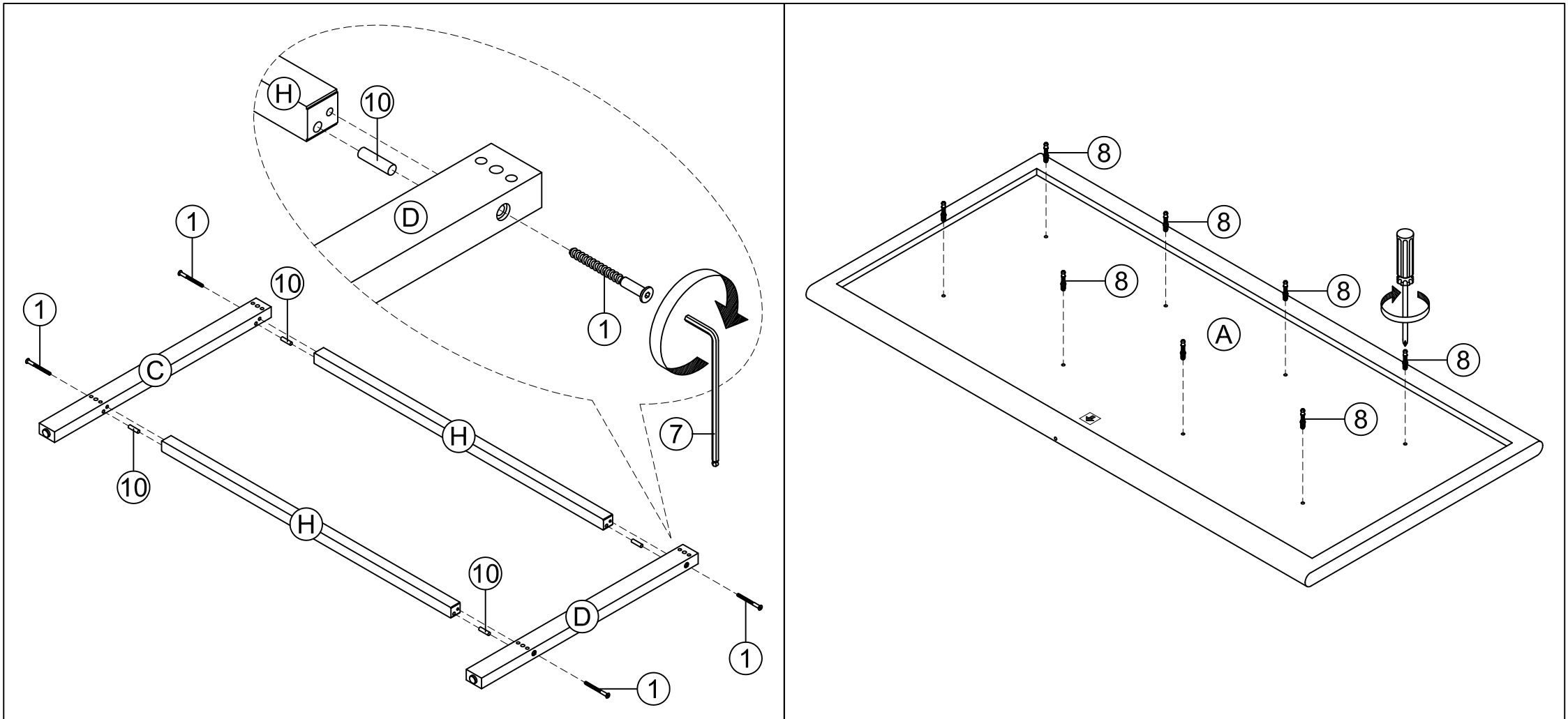

STEP 3 ATTACH BACK STRETCHERS TO LEFT AND RIGHT BACK LEGS USING 90mm ASSEMBLY SCREWS AND DOWELS. TIGHTEN SCREWS USING ALLEN KEY.

STEP 4 INSERT CAMBOLTS INTO PRE-DRILLED HOLES IN TOP PANEL, THEN TIGHTEN. SCREW-IN CAMBOLTS MUST BE SCREWED DOWN FLUSH.

PREPARATION

Before beginning assembly of product, make sure all parts are present. Compare parts with package contents list and hardware contents list.

If any part is missing or damaged, do not attempt to assemble the product.

Estimated Assembly Time: 30 minutes.

Tools Required for Assembly : Phillips Screwdriver

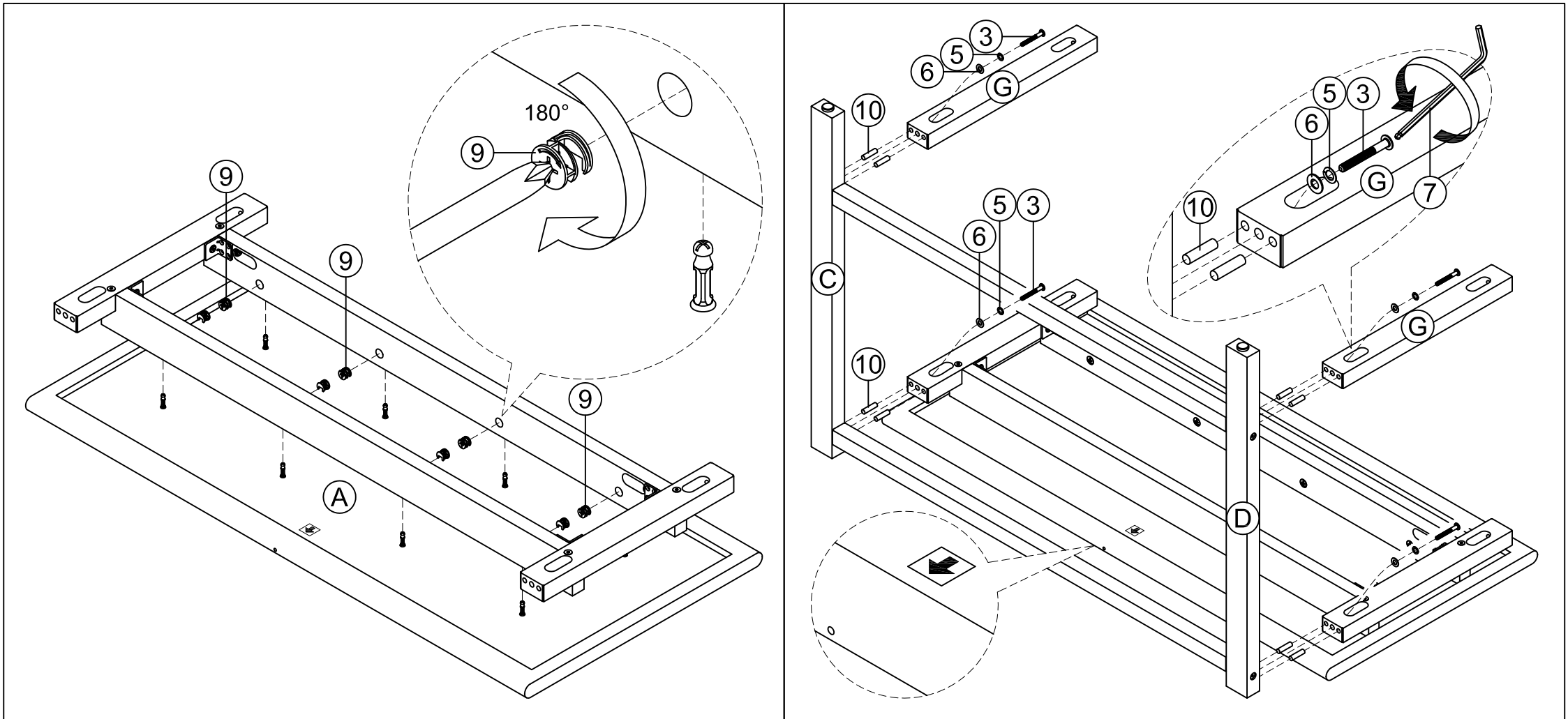

STEP 5 ATTACH UNIT FROM STEP 2 TO TOP PANEL USING CAMLOCKS.

STEP 6 ATTACH LOWER SIDE STRETCHERS AND UNIT FROM STEP 5 TO UNIT FROM STEP 3 USING 50mm HEAD CAP BOLTS, SPRING WASHERS, FLAT WASHERS AND DOWELS. TIGHTEN BOLTS USING ALLEN KEY.
NOTE: PAY ATTENTION TO THE POSITION OF THE ARROW LABEL IN THE TOP PANEL.

PREPARATION

Before beginning assembly of product, make sure all parts are present. Compare parts with package contents list and hardware contents list.

If any part is missing or damaged, do not attempt to assemble the product.

Estimated Assembly Time: 30 minutes.

Tools Required for Assembly : Phillips Screwdriver

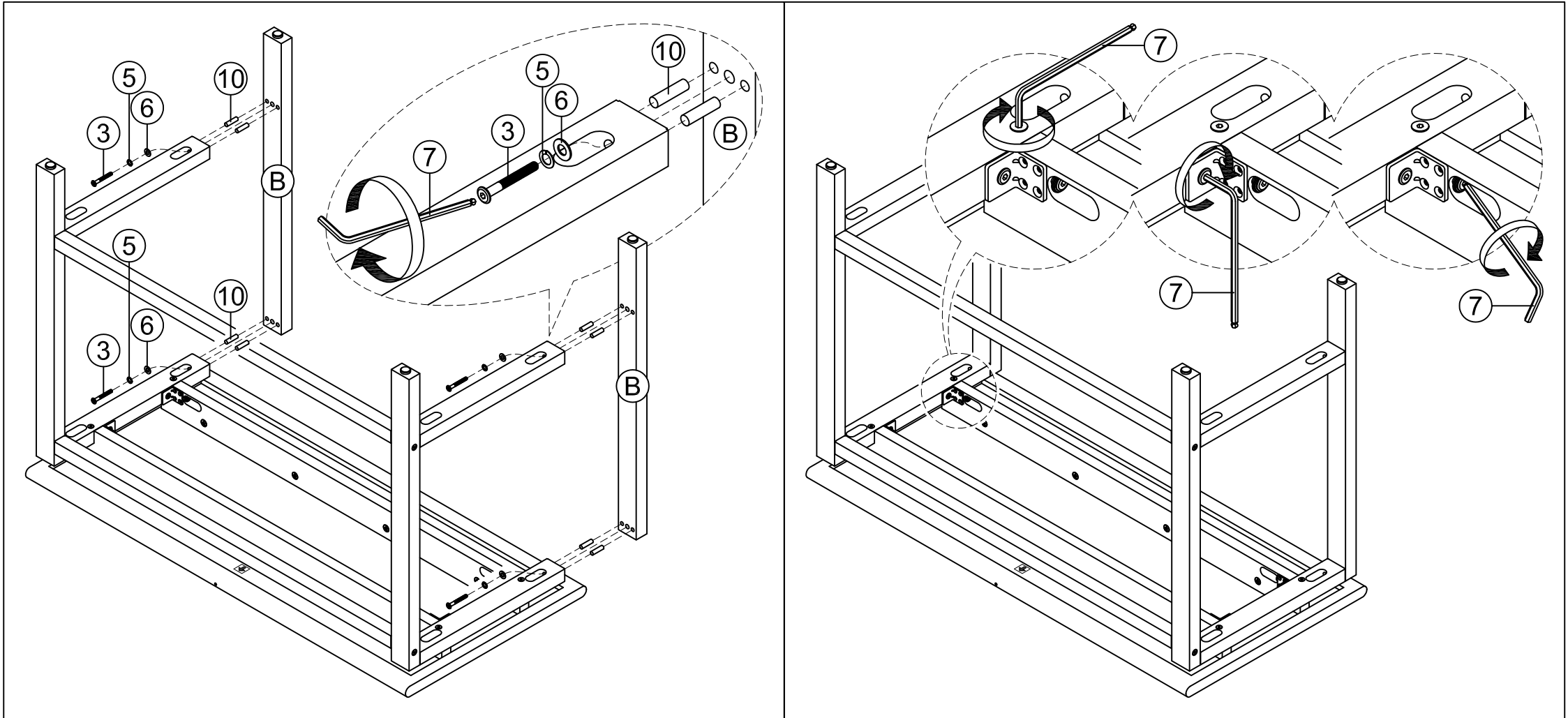

STEP 7 ATTACH FRONT LEGS TO UNIT USING 50mm HEAD CAP BOLTS, SPRING WASHERS, FLAT WASHERS AND DOWELS. TIGHTEN BOLTS USING ALLEN KEY.

STEP 8 TIGHTEN ALL SCREWS AND BOLTS FROM STEP 1 AND 2 USING ALLEN KEY.

PREPARATION

Before beginning assembly of product, make sure all parts are present. Compare parts with package contents list and hardware contents list. If any part is missing or damaged, do not attempt to assemble the product.

Estimated Assembly Time: 30 minutes.

Tools Required for Assembly : Phillips Screwdriver

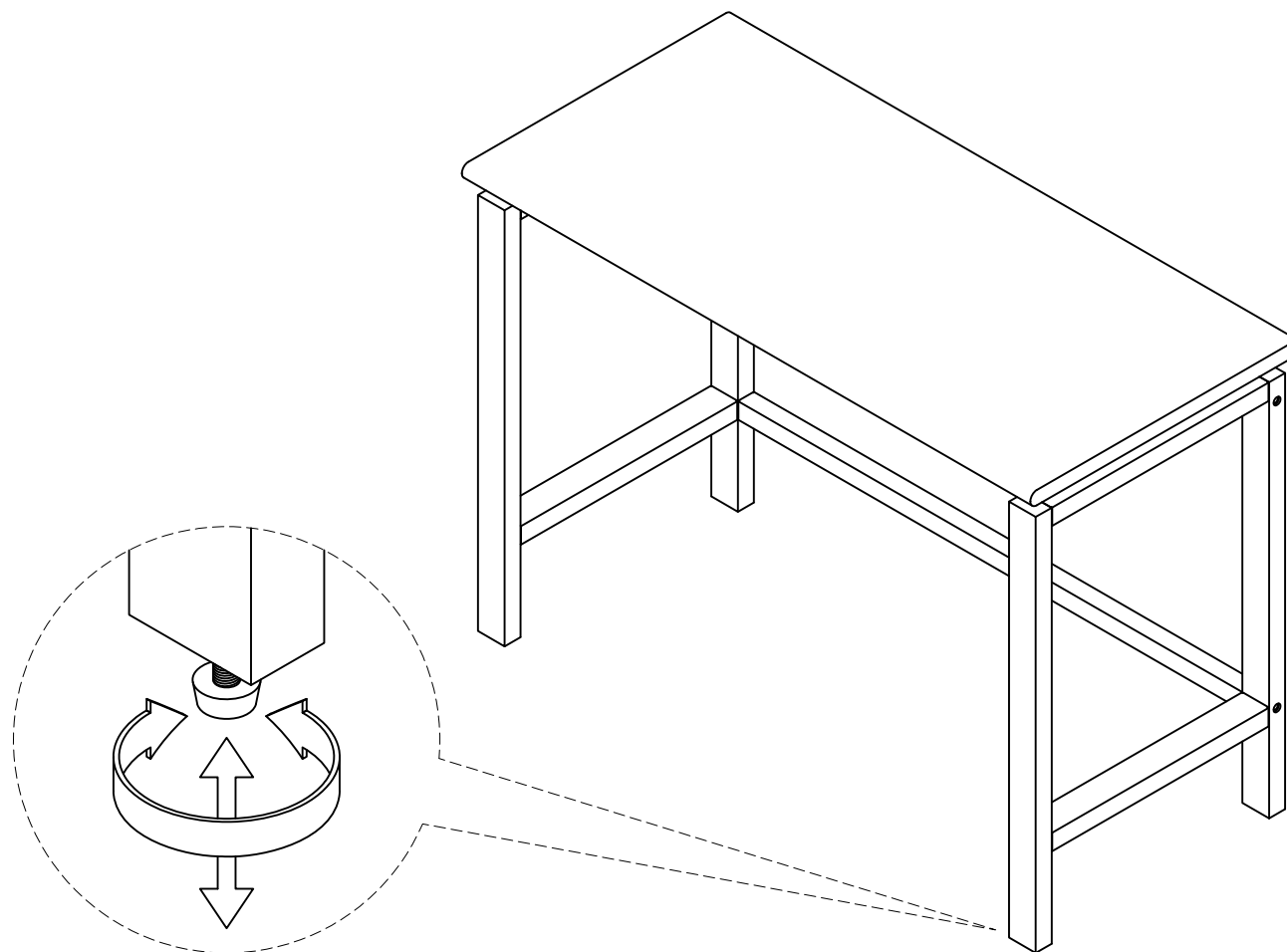

STEP 9 ADJUST THE ADJUSTER BOLT THAT HAS ALREADY ASSEMBLED TO THE LEGS TO STABILIZE YOUR UNIT.