















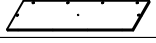
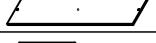

CARE AND MAINTENANCE

Spot clean using a mild water-free solvent. Only a professional cleaner should undertake a complete overall cleaning.
The use of steam or water-based cleaners may cause excessive shrinking or staining.

NOTICE

- * Please make sure that you have all parts indicated before you begin assembly of this item.
- * This item should be assembled on a soft surface to prevent scratching the finish during assembly.
- * This item may require periodic tightening.

Part List and Hardware List

PIECE	DESCRIPTION	PICTURE	QTY	CARTON CALL
A	TOP PANEL		1X	1 OF 2
B	LEFT ASSEMBLY		1X	2 OF 2
C	RIGHT ASSEMBLY		1X	2 OF 2
D	FRONT RAIL		2X	1 OF 2
E	DIVIDER		1X	2 OF 2
F	DIVIDER RAIL		1X	1 OF 2
G	BOTTOM ASSEMBLY		1X	1 OF 2
H	UPPER BACK PANEL		1X	1 OF 2
I	LOWER BACK PANEL		1X	1 OF 2
J	LEG FRAME		2X	1 OF 2
K	SIDE LEG		2X	1 OF 2
L	MIDDLE LEG		1X	1 OF 2
M	DRAWER FRONT		6X	1 OF 2
N	DRAWER LEFT		6X	2 OF 2
O	DRAWER RIGHT		6X	2 OF 2
P	DRAWER BACK		4X 2X	1 OF 2 2 OF 2
Q	DRAWER BASE		6X	1 OF 2
R	DRAWER SUPPORT		6X	1 OF 2

SAFAVIEH FURNITURE





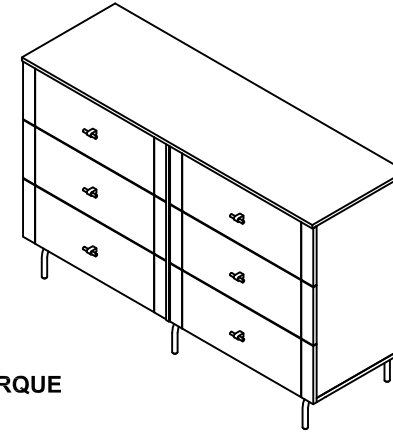







Model# DRS5002A

Product Dimensions: 56 1/32"W x 18"D x 36"H



WEIGHT CAPACITY:
TOP: 110 LBS
DRAWER: 30 LBS

**WARNING: DO NOT OVER TORQUE
BOLTS/SCREWS**

PIECE	DESCRIPTION	PICTURE	QTY	CARTON CALL
1	25 MM BOLT	M6x25mm 	8X	2 OF 2
2	1 1/4" ROUND HEAD SCREW	M4x32mm 	2X	2 OF 2
3	1 1/4" FLAT HEAD SCREW	M3x32mm 	90X	2 OF 2
4	3/4" FLAT HEAD SCREW	M3x19mm 	24X	2 OF 2
5	CAMBOLT		40X	2 OF 2
6	CAMLOCK		40X	2 OF 2
7	HANDLE		6X	2 OF 2
8	MACHINE SCREW	M4x22mm 	6X	2 OF 2
9	DOWEL		11X	2 OF 2
10	FLAT WASHER		6X	2 OF 2
11	HEX. NUT		6X	2 OF 2
12	HEX. WRENCH		1X	2 OF 2
13	ALLEN KEY		1X	2 OF 2

PREPARATION

Before beginning assembly of product, make sure all parts are present. Compare parts with package contents list and hardware contents list.

If any part is missing or damaged, do not attempt to assemble the product.

Estimated Assembly Time: 60 minutes.

Tools Required for Assembly : Phillips Screwdriver

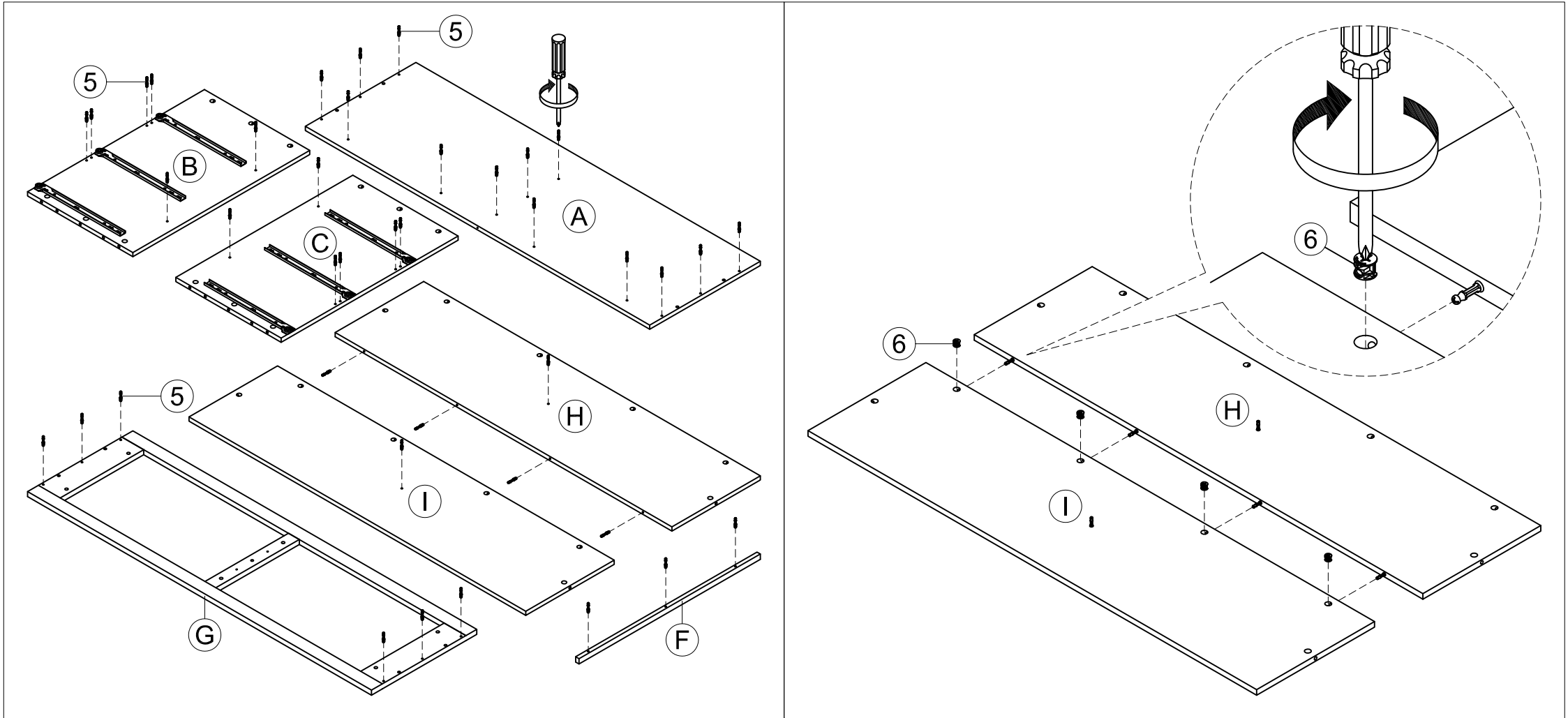

STEP 1 ATTACH CAMBOLTS TO TOP PANEL, LEFT AND RIGHT ASSEMBLIES, DIVIDER RAIL, BOTTOM ASSEMBLY, UPPER AND LOWER BACK PANELS.

STEP 2 ATTACH LOWER BACK PANEL TO UPPER BACK PANEL USING CAMLOCK.

PREPARATION

Before beginning assembly of product, make sure all parts are present. Compare parts with package contents list and hardware contents list.

If any part is missing or damaged, do not attempt to assemble the product.

Estimated Assembly Time: 60 minutes.

Tools Required for Assembly : Phillips Screwdriver

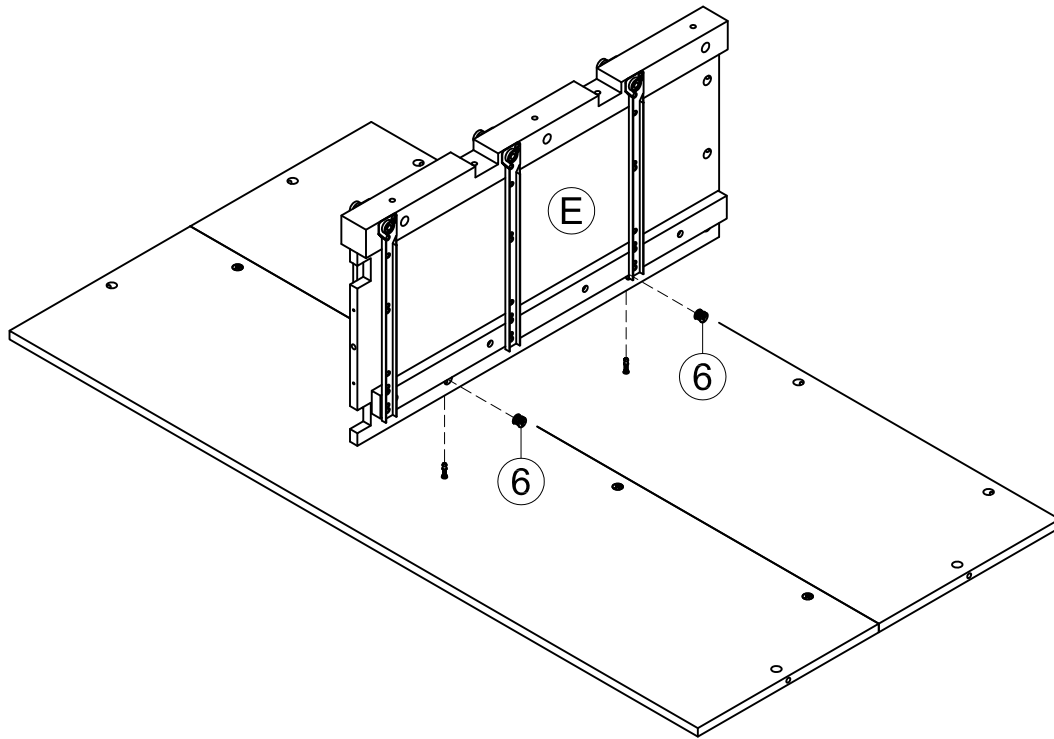

STEP 3 ATTACH DIVIDER TO UNIT USING CAMLOCKS.

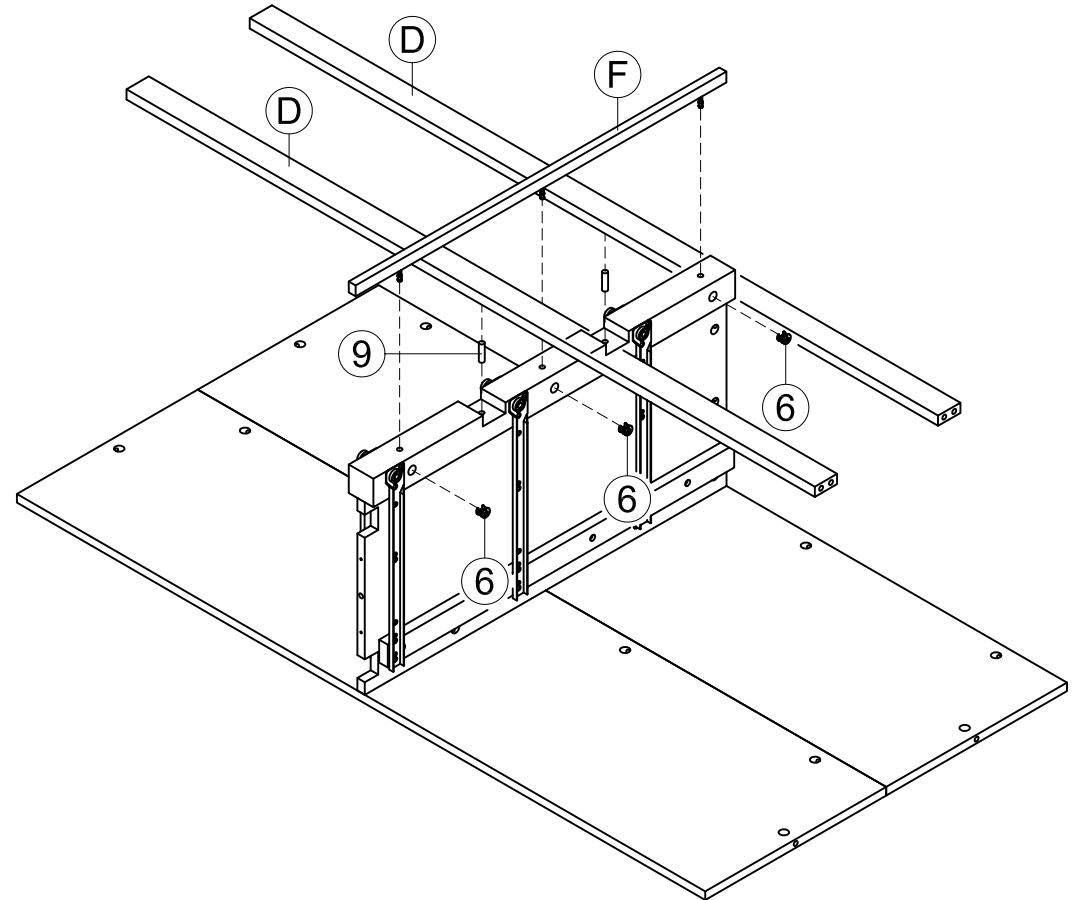

STEP 4 ATTACH FRONT RAILS TO UNIT USING DOWELS. ATTACH DIVIDER RAIL TO UNIT USING CAMLOCKS.

PREPARATION

Before beginning assembly of product, make sure all parts are present. Compare parts with package contents list and hardware contents list.

If any part is missing or damaged, do not attempt to assemble the product.

Estimated Assembly Time: 60 minutes.

Tools Required for Assembly : Phillips Screwdriver

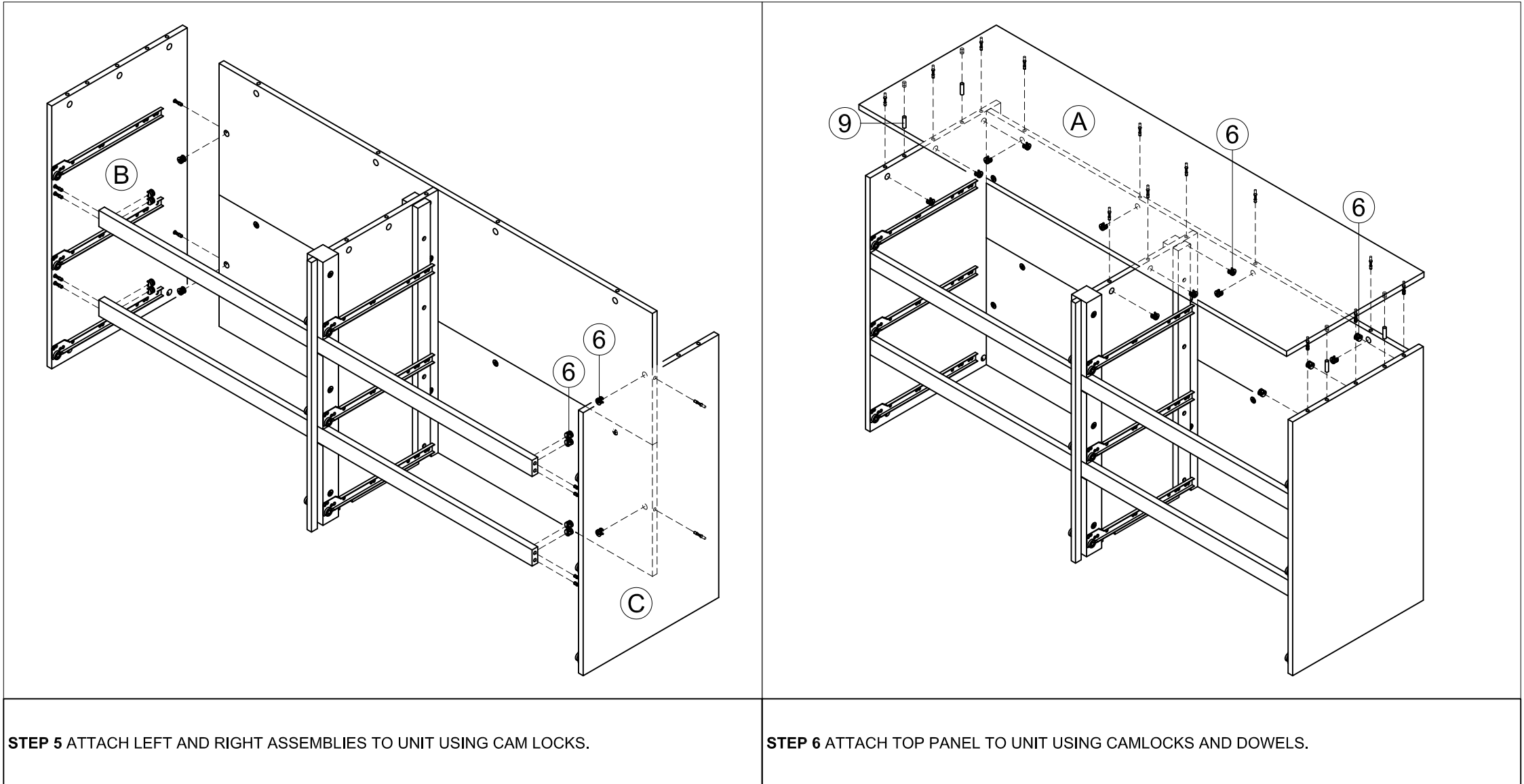

PREPARATION

Before beginning assembly of product, make sure all parts are present. Compare parts with package contents list and hardware contents list.

If any part is missing or damaged, do not attempt to assemble the product.

Estimated Assembly Time: 60 minutes.

Tools Required for Assembly : Phillips Screwdriver

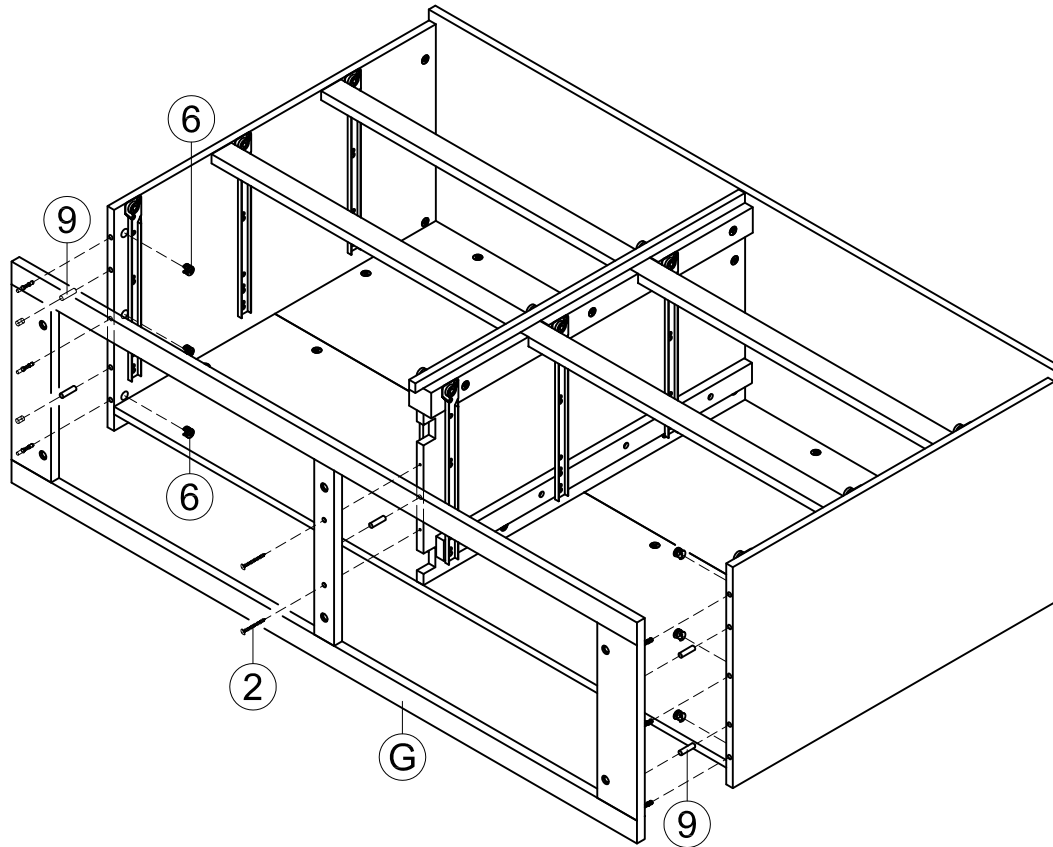

STEP 7 ATTACH BOTTOM ASSEMBLY TO UNIT USING 1 1/4" ROUND HEAD SCREWS, CAMLOCKS AND DOWELS.

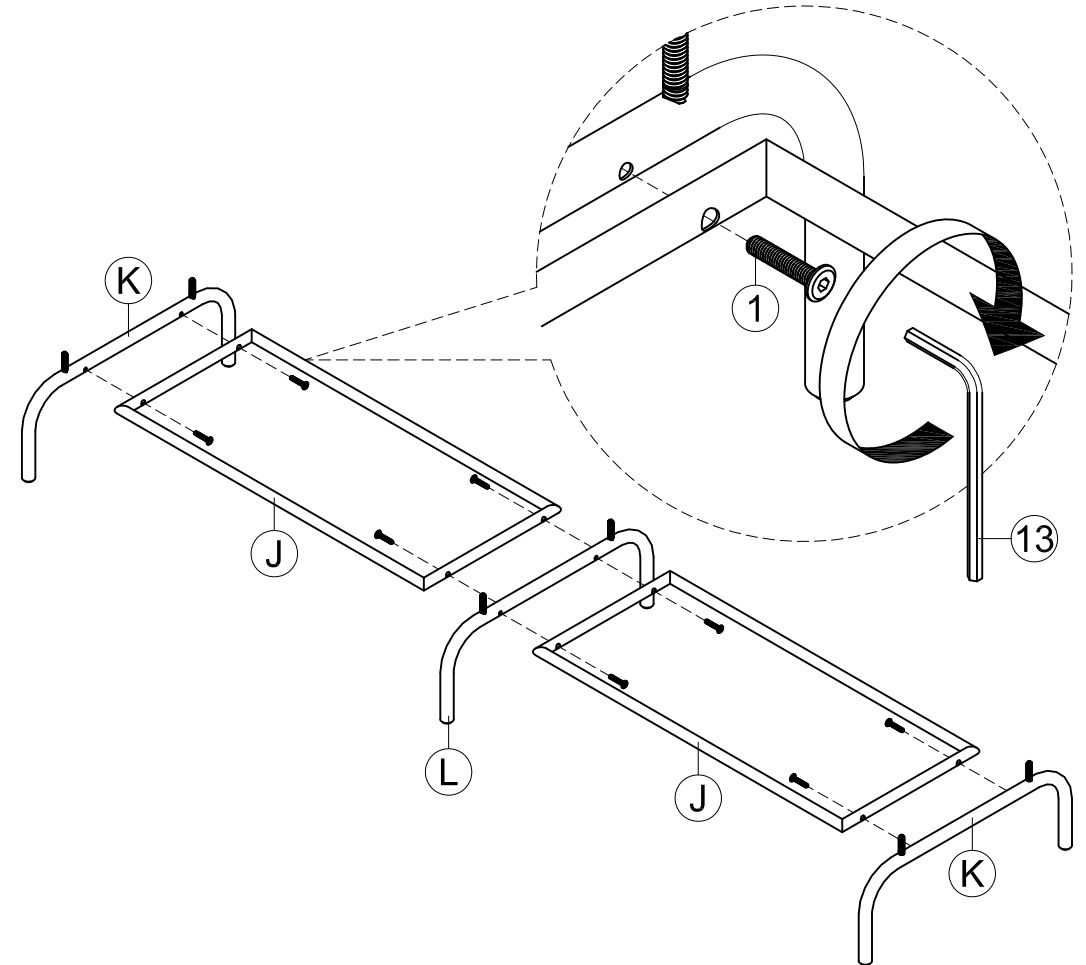

STEP 8 ATTACH LEG FRAMES TO SIDE AND MIDDLE LEGS USING 25 MM BOLTS. TIGHTEN BOLTS USING ALLEN KEY.

PREPARATION

Before beginning assembly of product, make sure all parts are present. Compare parts with package contents list and hardware contents list.

If any part is missing or damaged, do not attempt to assemble the product.

Estimated Assembly Time: 60 minutes.

Tools Required for Assembly : Phillips Screwdriver

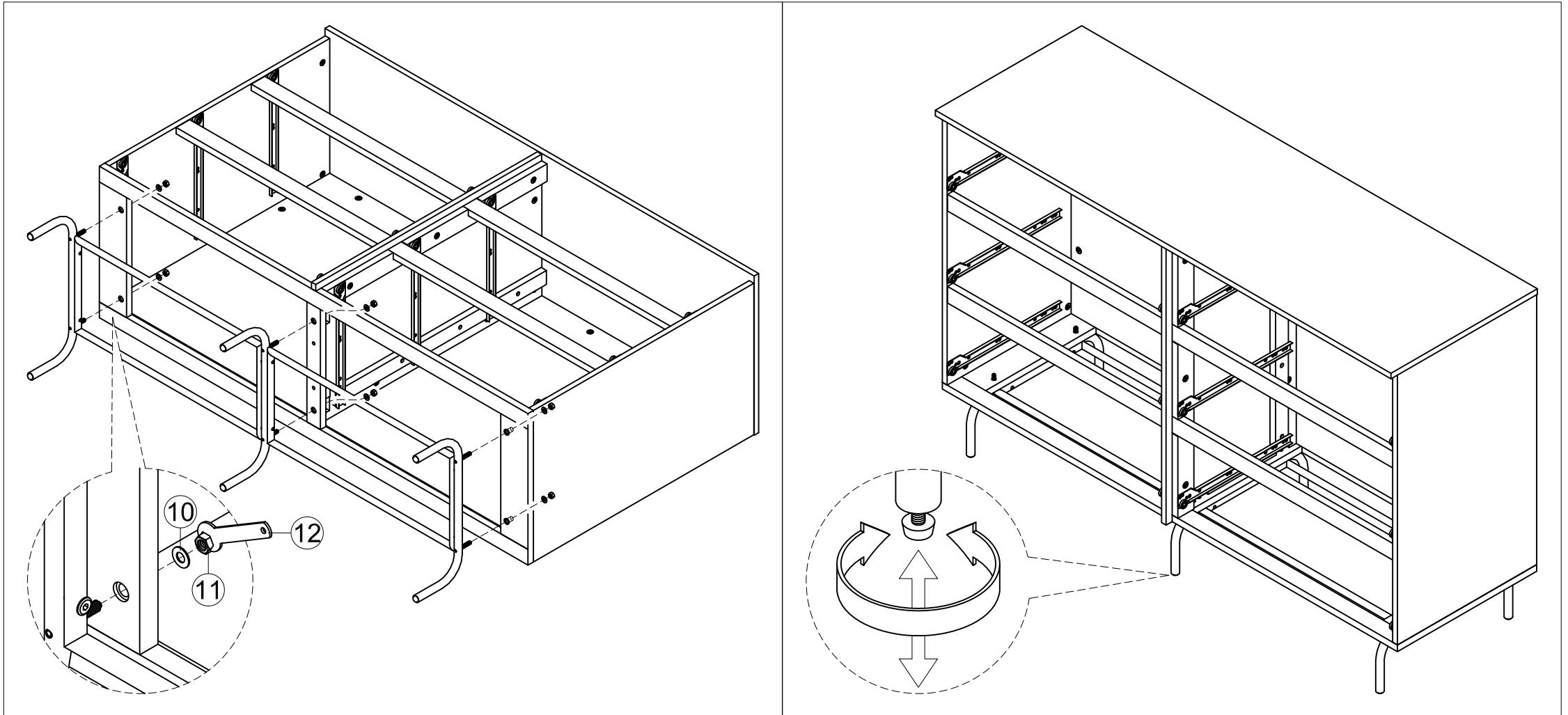

STEP 9 ATTACH UNIT FROM STEP 8 TO UNIT FROM STEP 7 USING FLAT WASHERS AND HEX. NUTS. TIGHTEN NUTS USING HEX. WRENCH.

STEP 10 ADJUST THE ADJUSTER THAT HAS ALREADY BEEN ASSEMBLED TO THE LEGS TO STABILIZE YOUR UNIT.

PREPARATION

Before beginning assembly of product, make sure all parts are present. Compare parts with package contents list and hardware contents list.

If any part is missing or damaged, do not attempt to assemble the product.

Estimated Assembly Time: 60 minutes.

Tools Required for Assembly : Phillips Screwdriver

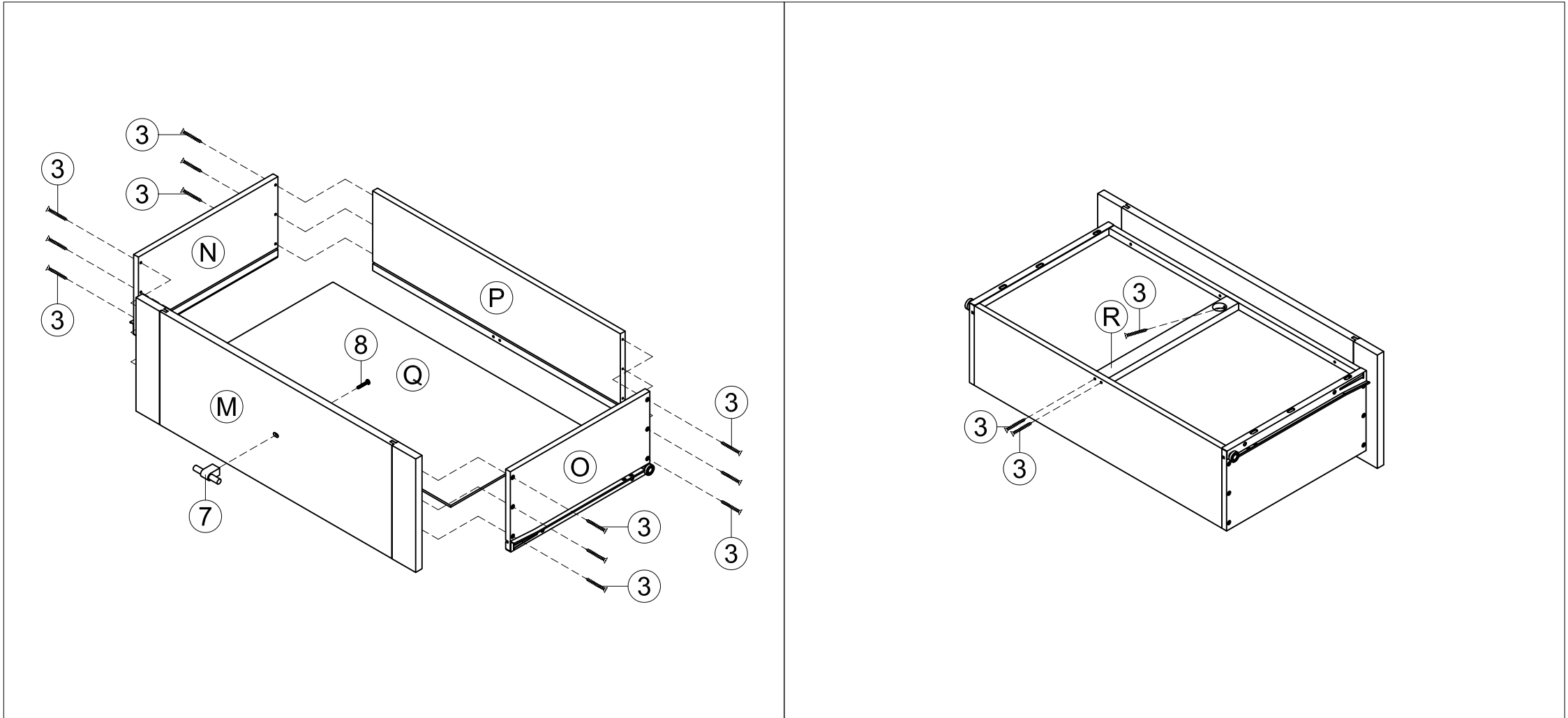

STEP 11 ATTACH HANDLE TO DRAWER FRONT USING MACHINE SCREW. ATTACH DRAWER LEFT AND RIGHT TO DRAWER BACK USING 1 1/4" FLAT HEAD SCREWS. SLIDE DRAWER BASE INTO THE GROOVE. ATTACH DRAWER FRONT TO DRAWER LEFT AND RIGHT USING 1 1/4" FLAT HEAD SCREWS.

STEP 12 ATTACH DRAWER SUPPORT TO UNIT USING 1 1/4" FLAT HEAD SCREWS.

PREPARATION

Before beginning assembly of product, make sure all parts are present. Compare parts with package contents list and hardware contents list.

If any part is missing or damaged, do not attempt to assemble the product.

Estimated Assembly Time: 60 minutes.

Tools Required for Assembly : Phillips Screwdriver

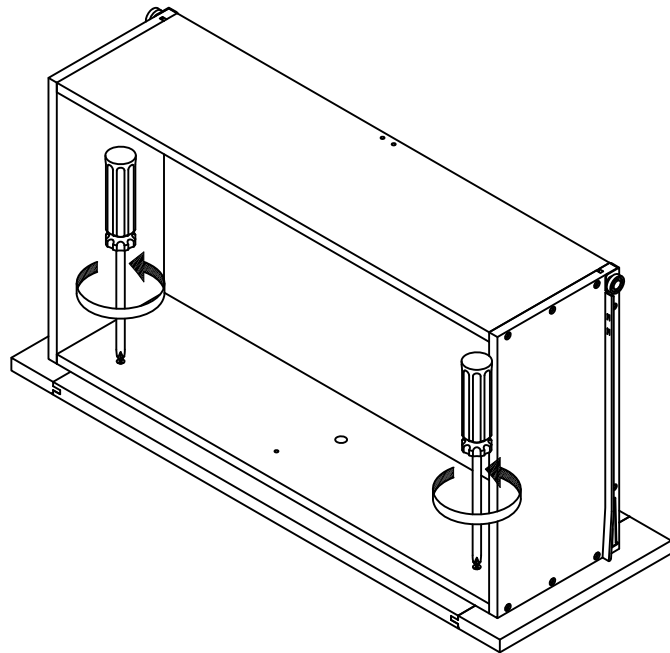

STEP 13 LOOSEN SLIGHTLY THE SCREWS PRE-INSTALLED ON THE BACK OF THE DRAWER FRONTS.

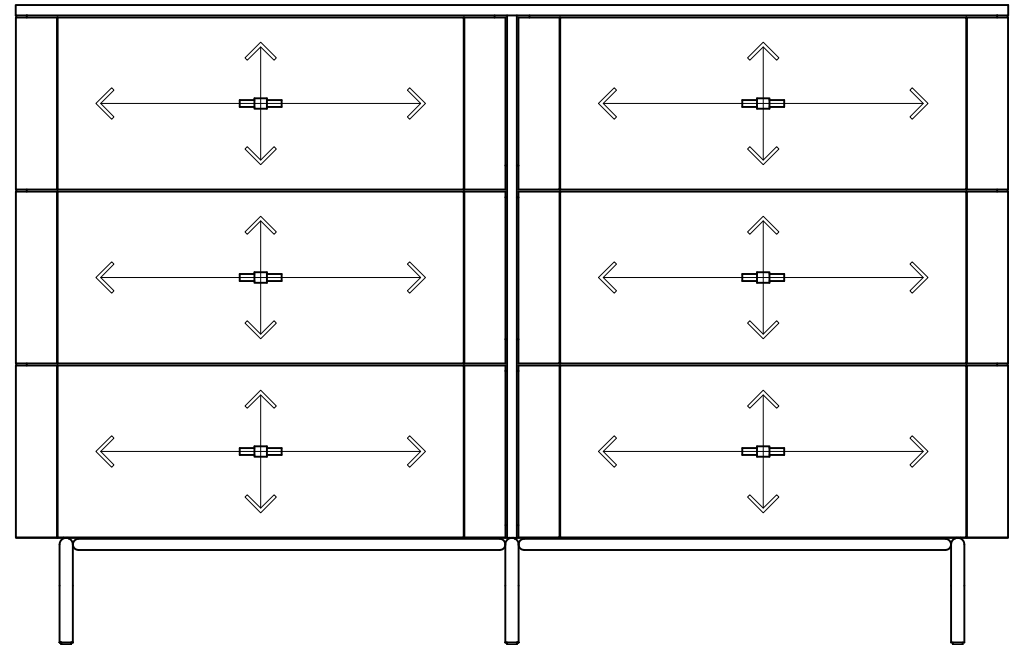

STEP 14 INSERT THE DRAWER INTO THE UNIT, THEN ADJUST THE DRAWER FRONT PANEL LEFT OR RIGHT AND UP OR DOWN UNTIL THE DRAWER GAPS LOOK PROPORTIONAL.

PREPARATION

Before beginning assembly of product, make sure all parts are present. Compare parts with package contents list and hardware contents list.

If any part is missing or damaged, do not attempt to assemble the product.

Estimated Assembly Time: 60 minutes.

Tools Required for Assembly : Phillips Screwdriver

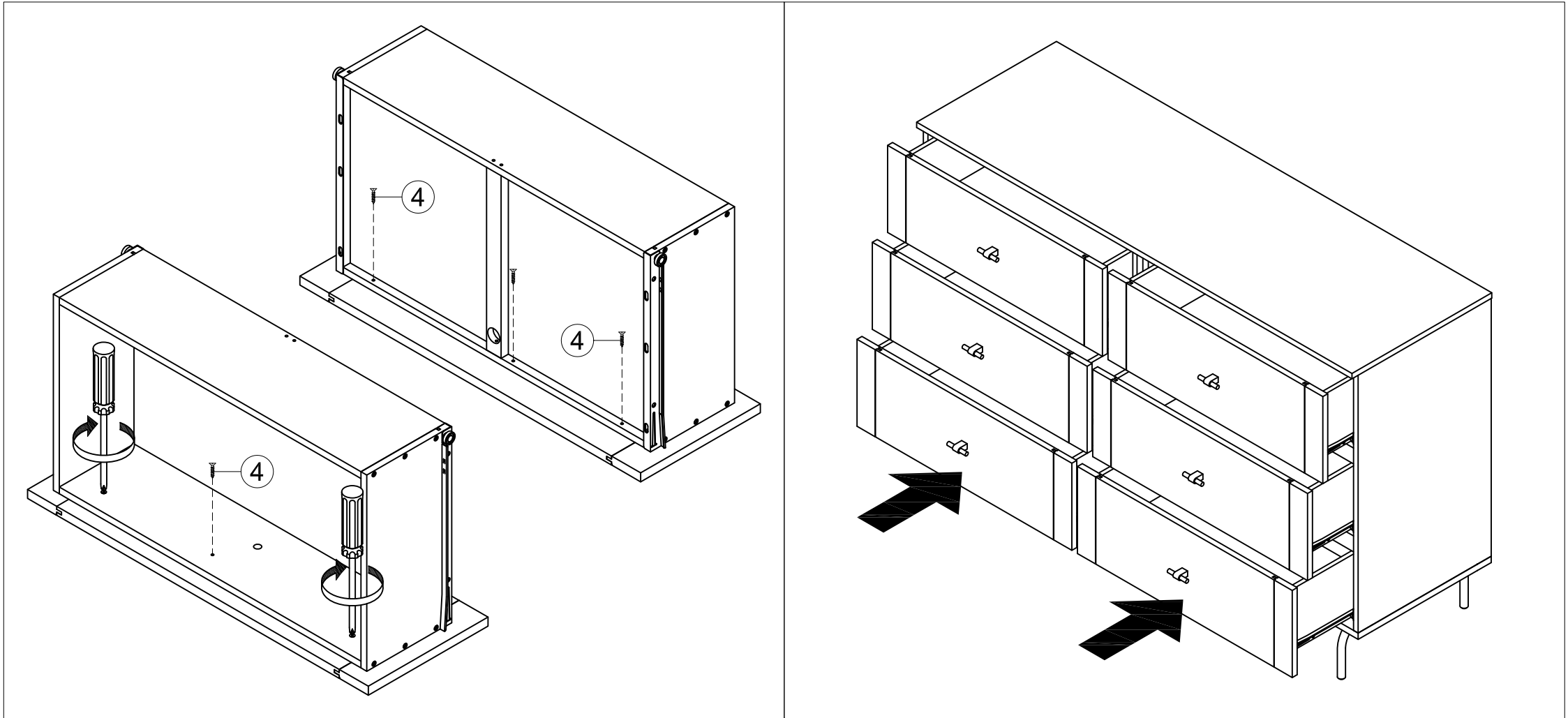

STEP 15 PULL THE DRAWER OPEN SLOWLY AND RE-TIGHTEN THE SCREWS FROM STEP 13. MAKE SURE THE FRONT PANEL DOES NOT MOVE AND LOCK THE DRAWER FRONT PANEL INTO POSITION WITH 3/4" FLAT HEAD SCREWS.

STEP 16 INSERT THE DRAWERS INTO UNIT.