





## CARE AND MAINTENANCE

Wipe clean with a soft, dry cloth. Test the cleaning method on a hidden area before using them over the entire area.

## NOTICE

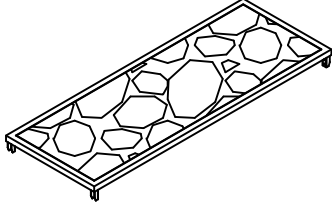
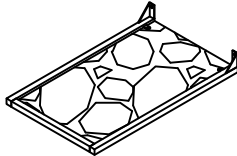
- \* Please make sure that you have all parts indicated before you begin assembly of this item.
- \* This item should be assembled on a soft surface to prevent scratching the finished product during assembly.
- \* This item may require periodic tightening.
- \* Do not tighten bolts until completely assembled.

## Part List and Hardware List

PIECE	DESCRIPTION	PICTURE	QUANTITY
A	Top Panel		1x
B	Side Frame		2x
H1	Allen Bolt	 1/4"x5/8"	12x
H2	Spring Washer	 1/4"	12x
H3	Flat Washer	 $\phi 13*1.0$	12x
H4	Allen Key	 M4	1x

 **SAFAVIEH**  
FURNITURE

Model# CNS6201

Product Dimensions: 48"W\*18"Dx30"H

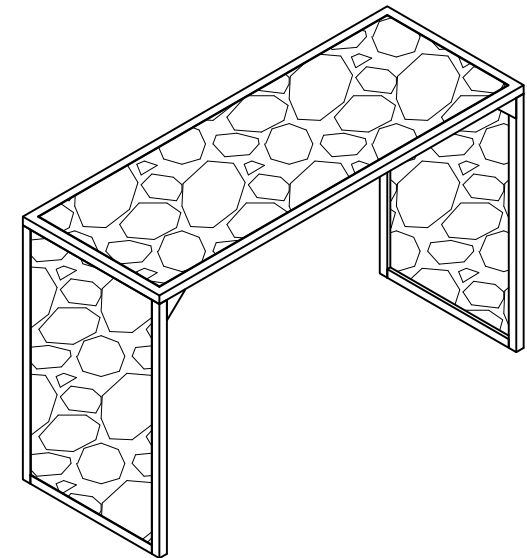

Weight capacity:25lbs  
WARNING:DO NOT STAND ON TABLE  
WARNING:DO NOT OVER TORQUE BOLTS

## PREPARATION

Before beginning assembly of product, make sure all parts are present. Compare parts with package contents list and hardware contents list. If any part is missing or damaged, do not attempt to assemble the product.

Estimated Assembly Time: 20 minutes.

Tools Required for Assembly (included): Allen Key

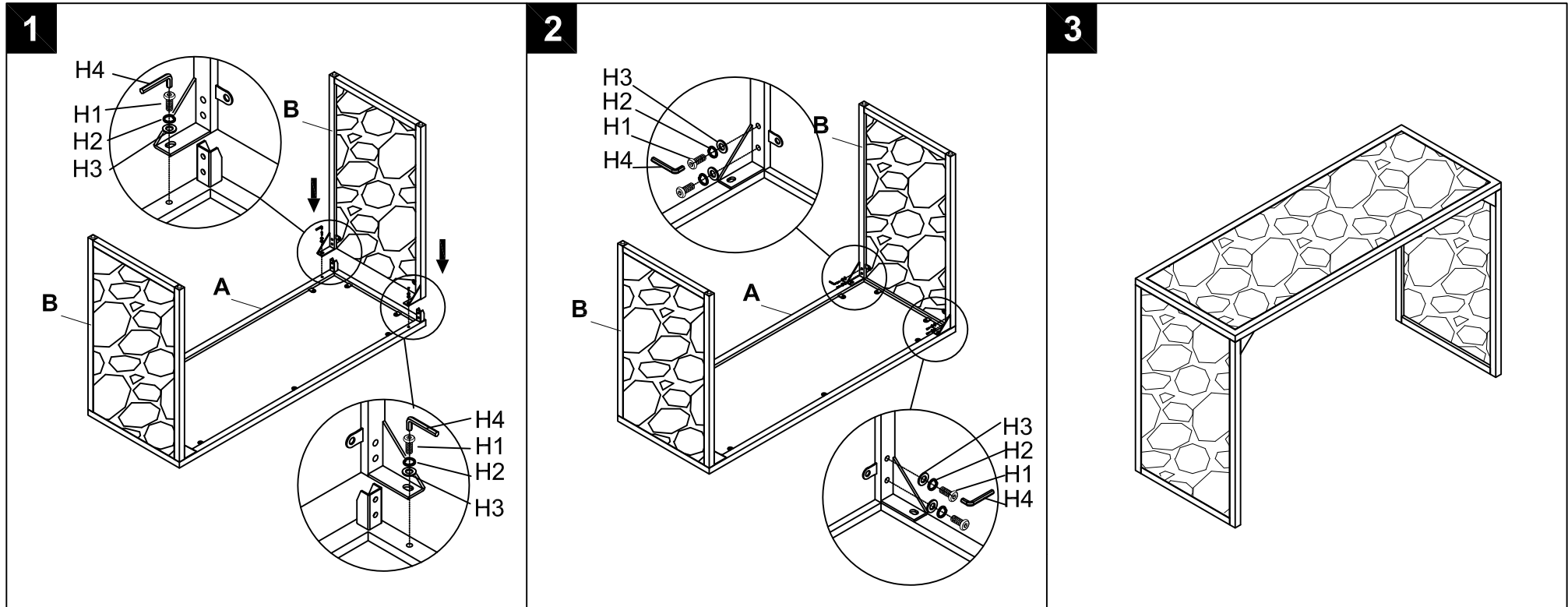

### Step 1

Attach 2\*side frames (B) to the underneath of top panel (A), Use Allen Key (H4) to lock through holes on metal side frame with flat washer (H3), spring washer (H2) and Allen bolts (H1).as picture.

### Step2

Use Allen Key (H4) to lock through holes on metal side frame with flat washer (H3), spring washer (H2) and Allen bolts (H1).as picture.

### Step 3

**Straighten up the assembled table, Assembly is completed.**