

## NOTICE

\*Please make sure that you have all parts indicated and they are in good condition before you begin assembly of this item. Refer to part list and hardware list below for guidance.

\*This item should be assembled on a soft surface to prevent scratching the finish during assembly.

\*This item may require periodic tightening.

\*If you are having difficulty, our friendly Customer Care team is always here to help. Please email [customersupport@safavieh.com](mailto:customersupport@safavieh.com)

## PREPARATION

\*Before beginning assembly of product, make sure all parts are present. Compare parts with part contents list and hardware contents list.

\*If any part is missing or damaged, do not attempt to assemble the product.

\*Estimated Assembly Time: 60 minutes.

\*Tools Required for Assembly (included): Allen Key

## CARE AND MAINTENANCE

Always use felt pads under all articles to prevent discoloration or softening of the lacquer. Plastic and rubber bases on items can discolor wood. Wipe up spills immediately and avoid common hazards such as hot dishes, harsh solvents and abrasives. Cleaning should be done with a soft lint free cotton cloth dampened with water or furniture polish. On highly used surfaces we recommend applying a quality paste wax which should be used on a regular basis to provide additional protection from scratches and spills. How often you apply the wax depends on how much wear the furniture receives.

### Part List

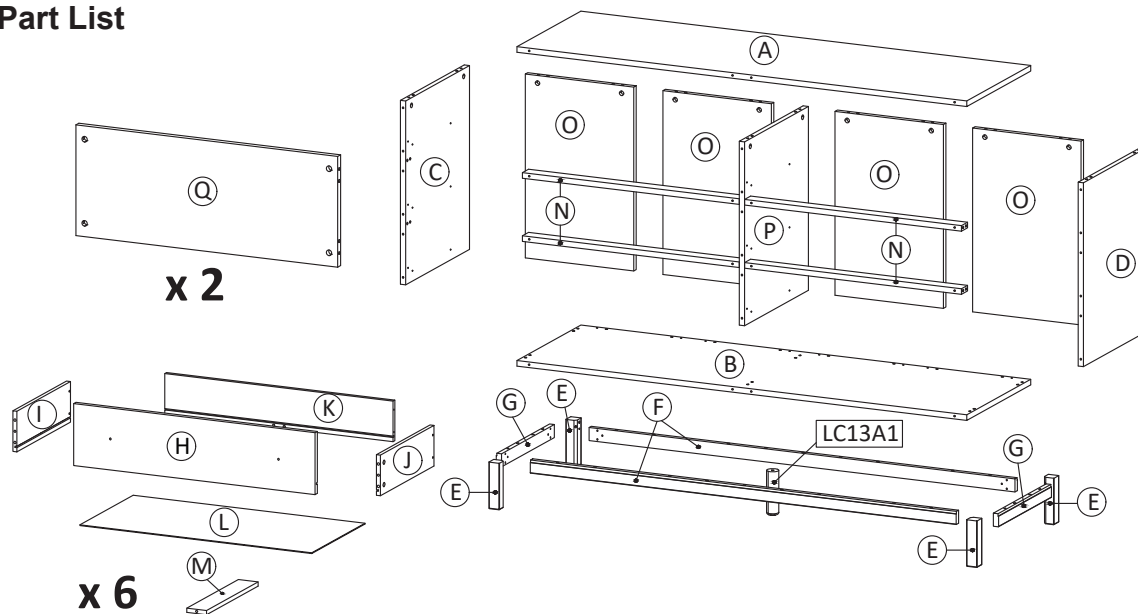

 **SAFAVIEH**  
FURNITURE

Model# CHS9601

Product Dimensions: 61"Wx19"Dx31"H

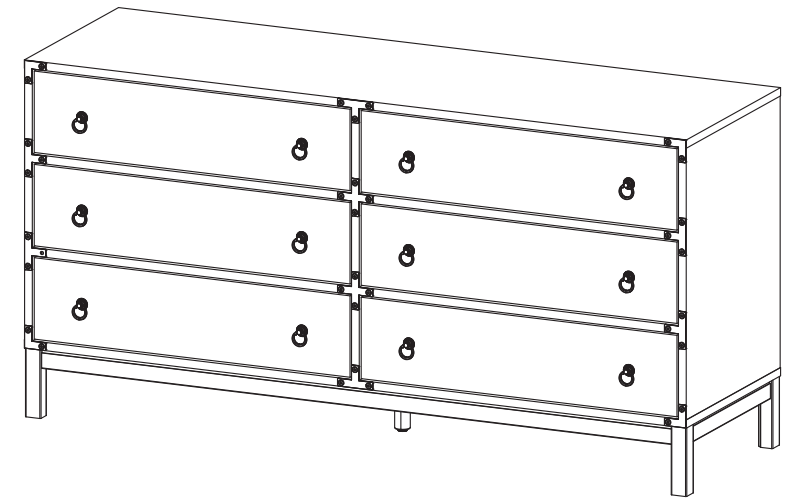

 **WARNING :**











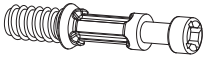



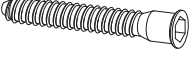

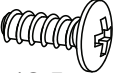



**WEIGHT CAPACITY: 103.6 LBS.**

**DRAWER LOAD CAPACITY 22 LBS**

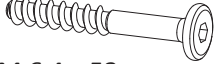
**Warning : Do not stand on chest.**

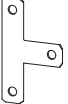
**Warning : Do not over torque bolts.**

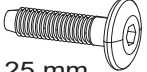
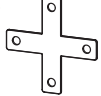
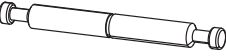
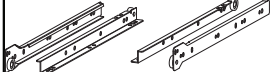
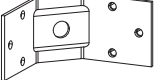
## Hardware List

<p>HW1x48</p>  <p>∅ 6 x 35 mm</p>	<p>HW2x22</p>  <p>∅ 15 mm</p>	<p>HW3x30</p>  <p>∅ 12 mm</p>	<p>HW4x54</p>  <p>∅ 8 x 30 mm</p>	<p>HW5x12</p>  <p>∅ 6 x 30 mm</p>	<p>HW6x14</p>  <p>M 7 x 50 mm</p>
<p>HW7x2</p>  <p>L 4</p>	<p>HW8x28</p>  <p>M 4.5 x 12.5 mm</p>	<p>HW9x36</p>  <p>M 6 x 10.5 mm</p>	<p>HW10x36</p>  <p>M 3.5 x 13 mm</p>	<p>HW11x36</p>  <p>M 8 x 39 mm</p>	<p>HW12x24</p> 
<p>HW13x24</p>  <p>M 3.5 x 15.5 mm</p>	<p>HW14x12</p> 	<p>HW15x12</p>  <p>M 4 x 20 mm</p>	<p>HW16x12</p>  <p>M 6.4 x 53 mm</p>	<p>HW17x34</p>  <p>M 6.4 x 14 mm</p>	<p>HW18x4</p> 
<p>HW19x6</p> 	<p>HW20x6</p>  <p>∅ 8 x 50 mm</p>	<p>HW21x4</p>  <p>M 6 x 25 mm</p>	<p>HW22x2</p> 	<p>HW23x2</p> 	<p>HW RM35Ax6</p>  <p>350 mm</p>
<p>HW BC410x4</p> 	<p>HW PM2x1</p> 				

### Part List & HW For Multi-Box Items

Piece	Description	Qty	Carton Call
A	Top Board	1	1 of 2
B	Bottom Board	1	1 of 2
C	Side Board Left	1	2 of 2
D	Side Board Right	1	2 of 2
E	Leg	4	2 of 2
F	Bottom Skirt 1	2	1 of 2
G	Bottom Skirt 2	2	1 of 2
H	Front Drawer	6	2 of 2
I	Side Drawer Left	6	1 of 2
J	Side Drawer Right	6	1 of 2
K	Back Drawer	6	1 of 2
L	Bottom Drawer	6	1 of 2
M	Support Drawer	6	1 of 2
N	Support Board	4	1 of 2
O	Back Board	4	2 of 2
P	Center Board	1	2 of 2
Q	Support Board 2	2	1 of 2
LC13A1	Center Leg	1	2 of 2

Piece	Description	Qty	Carton Call
HW1	Cambolt	48	2 of 2
HW2	CamLock Big	22	2 of 2
HW3	CamLock Small	30	2 of 2
HW4	Dowel Middle	54	2 of 2
HW5	Dowel Small	12	2 of 2
HW6	Screw M 7 x 50 mm	14	2 of 2
HW7	Allen Key	2	2 of 2
HW8	Screw M 4.5 x 12.5 mm	28	2 of 2
HW9	Screw M 6 x 10.5 mm	36	2 of 2
HW10	Screw M 3.5 x 13 mm	36	2 of 2
HW11	Screw M 8 x 39 mm	36	2 of 2
HW12	Wedge	24	2 of 2
HW13	Screw M 3.5 x 15.5 mm	24	2 of 2
HW14	Handle	12	2 of 2
HW15	Screw M 4 x 20 mm	12	2 of 2
HW16	Screw M 6.4 x 53 mm	12	2 of 2
HW17	Screw M 6.4 x 14 mm	34	2 of 2
HW18	Plat "L"	4	2 of 2
HW19	Plat "T"	6	2 of 2
HW20	Dowel Big	6	2 of 2
HW21	Screw M 6 x 25 mm	4	2 of 2
HW22	Plat "+"	2	2 of 2
HW23	Cambolt Double	2	2 of 2
HW RM35A	Rail	6	2 of 2
HW BC410	Corner Brace	4	2 of 2
HW PM2	Mounting Plate	1	2 of 2

# PREPARATION

\*Before beginning assembly of product, make sure all parts are present. Compare parts with part contents list and hardware contents list.

\*If any part is missing or damaged, do not attempt to assemble the product.

\*Estimated Assembly Time: 90 minutes.

\*Tools Required for Assembly (included): Allen Key

\*If you are having difficulty, our friendly Customer Care team is always here to help. Please email [customersupport@safavieh.com](mailto:customersupport@safavieh.com)

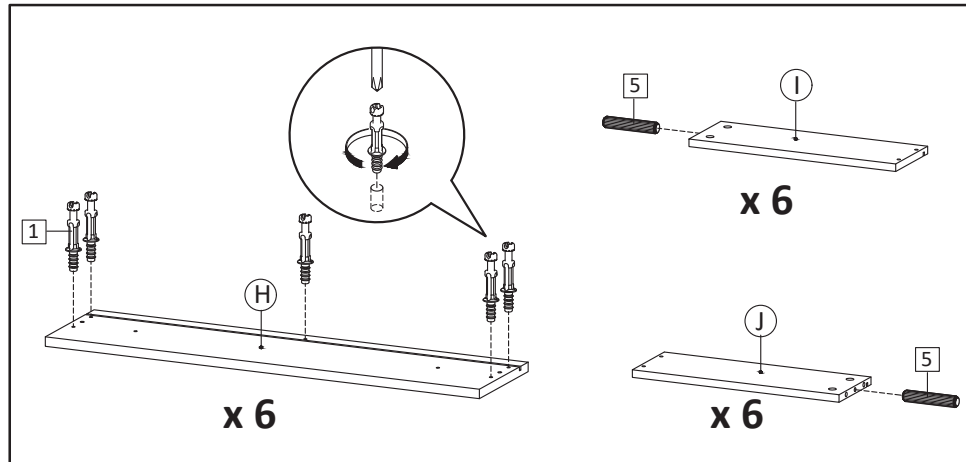

**STEP1:** Insert Cambolt (HW1) into Front Drawer (H).  
Insert Dowel Small (HW5) into Side Drawers ( I & J )

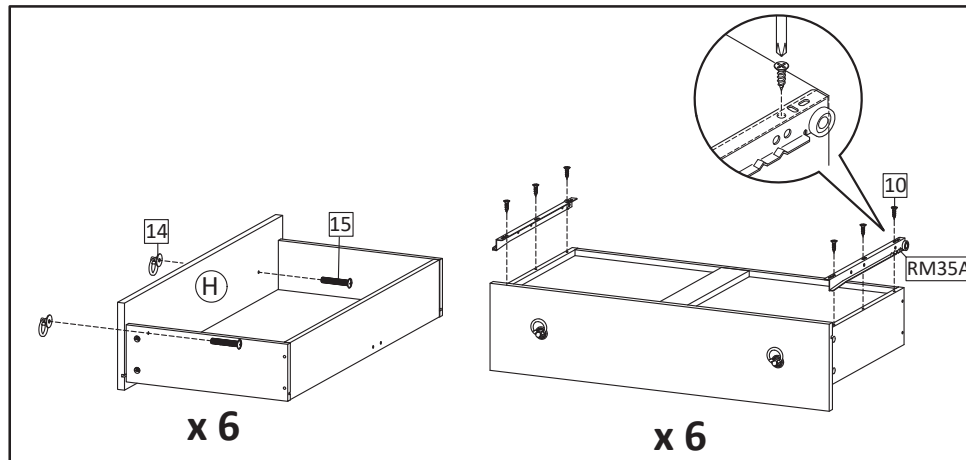

**STEP3:** Use Screw M4x20mm (HW15) to attach Handle (HW14)  
to the Front Drawer.  
Install the metal runner (HW RM35A) into position as shown in picture.  
Secure with screws M3.5x13mm (HW10)

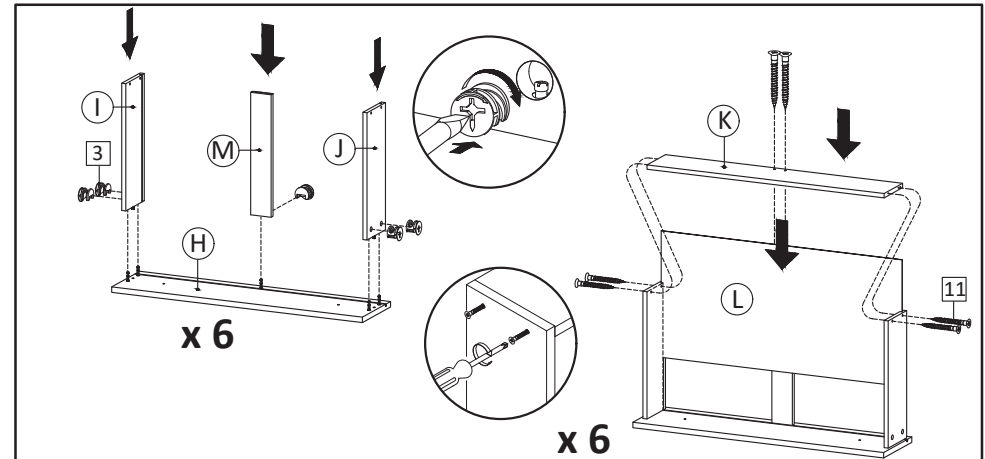

**STEP2:** Combine Side Drawers ( I & J ) and Support Drawer ( M )  
into Front Drawer ( H ) then tighten camlock ( HW3 ) using screwdriver.  
Insert Bottom Drawer ( L ) with laminated face facing upward then  
put Back Drawer ( K ) and secure with Screw M8x39mm ( HW11 ).

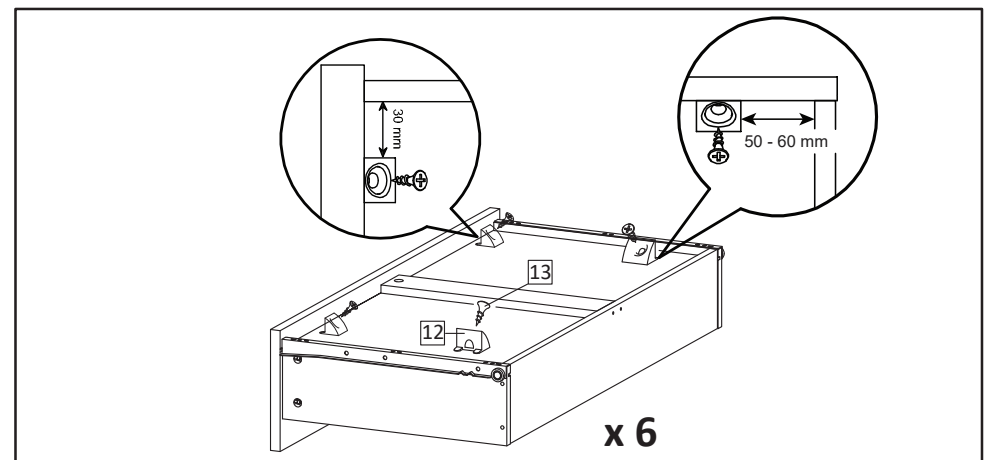

**STEP4:** Insert the Screw M3.5x15.5mm ( HW13 ) and wedge ( HW12 )  
into the bottom of the drawer according to the picture.

# PREPARATION

\*Before beginning assembly of product, make sure all parts are present. Compare parts with part contents list and hardware contents list.

\*If any part is missing or damaged, do not attempt to assemble the product.

\*Estimated Assembly Time: 90 minutes.

\*Tools Required for Assembly (included): Allen Key

\*If you are having difficulty, our friendly Customer Care team is always here to help. Please email [customersupport@safavieh.com](mailto:customersupport@safavieh.com)

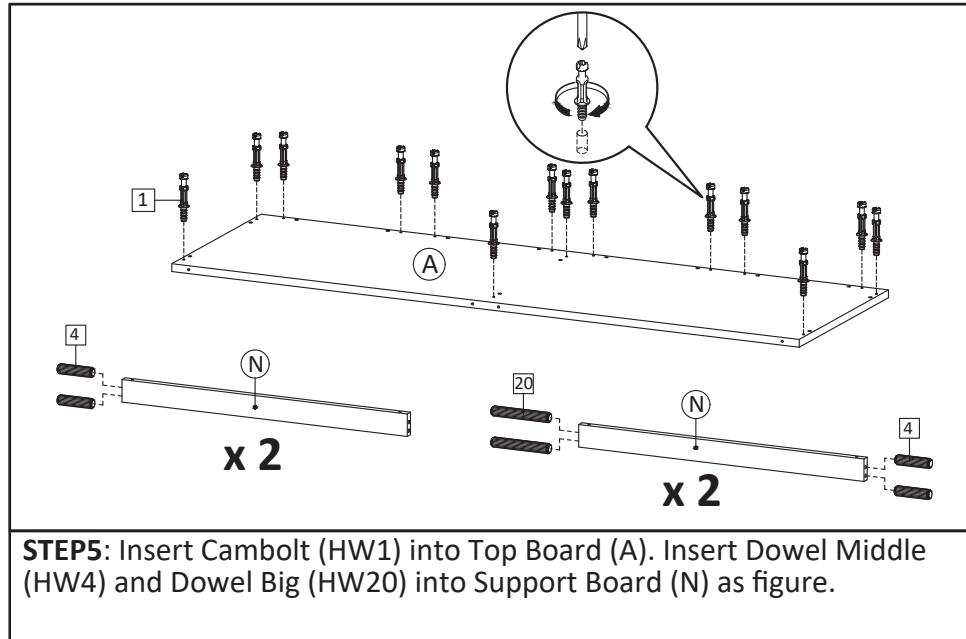

**STEP5:** Insert Cambolt (HW1) into Top Board (A). Insert Dowel Middle (HW4) and Dowel Big (HW20) into Support Board (N) as figure.

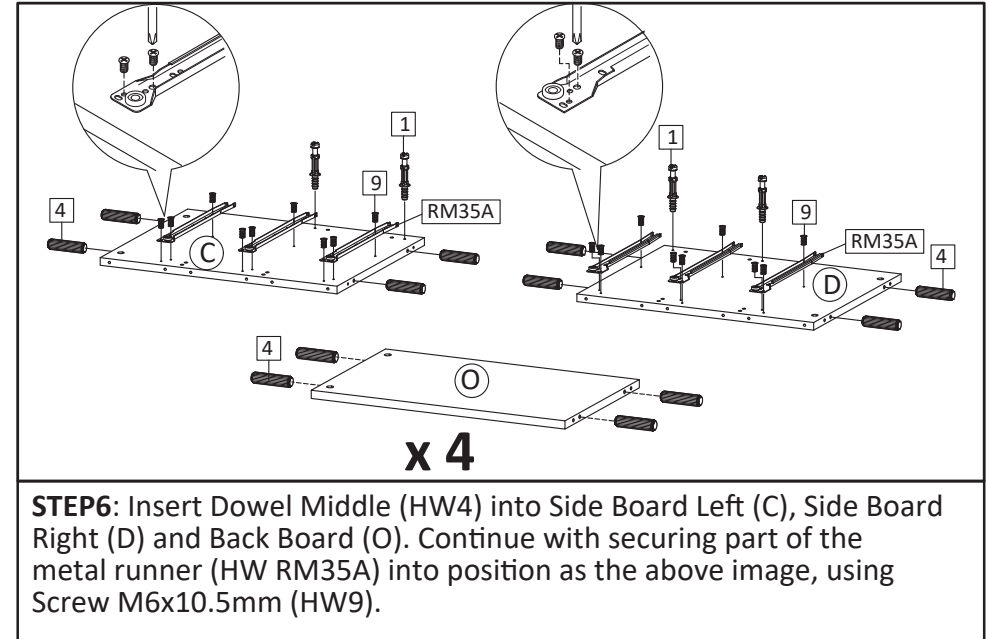

**STEP6:** Insert Dowel Middle (HW4) into Side Board Left (C), Side Board Right (D) and Back Board (O). Continue with securing part of the metal runner (HW RM35A) into position as the above image, using Screw M6x10.5mm (HW9).

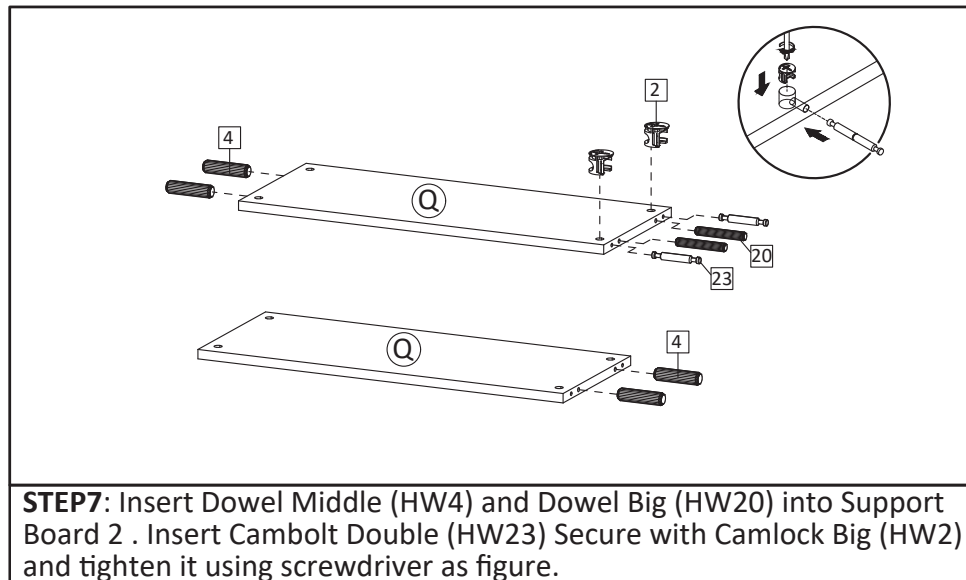

**STEP7:** Insert Dowel Middle (HW4) and Dowel Big (HW20) into Support Board 2. Insert Cambolt Double (HW23) Secure with Camlock Big (HW2) and tighten it using screwdriver as figure.

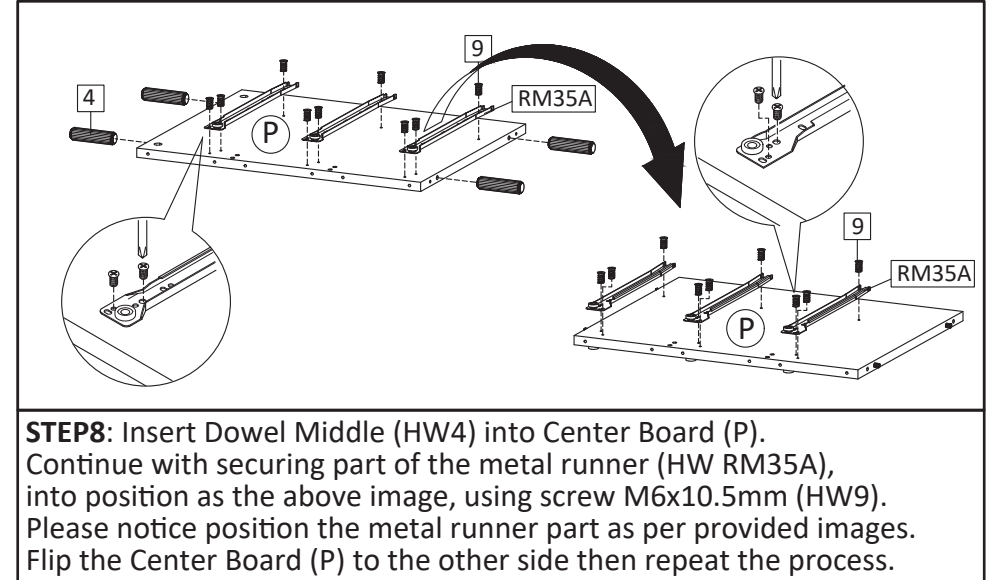

**STEP8:** Insert Dowel Middle (HW4) into Center Board (P). Continue with securing part of the metal runner (HW RM35A), into position as the above image, using screw M6x10.5mm (HW9). Please notice position the metal runner part as per provided images. Flip the Center Board (P) to the other side then repeat the process.

# PREPARATION

\*Before beginning assembly of product, make sure all parts are present. Compare parts with part contents list and hardware contents list.

\*If any part is missing or damaged, do not attempt to assemble the product.

\*Estimated Assembly Time: 90 minutes.

\*Tools Required for Assembly (included): Allen Key

\*If you are having difficulty, our friendly Customer Care team is always here to help. Please email [customersupport@safavieh.com](mailto:customersupport@safavieh.com)

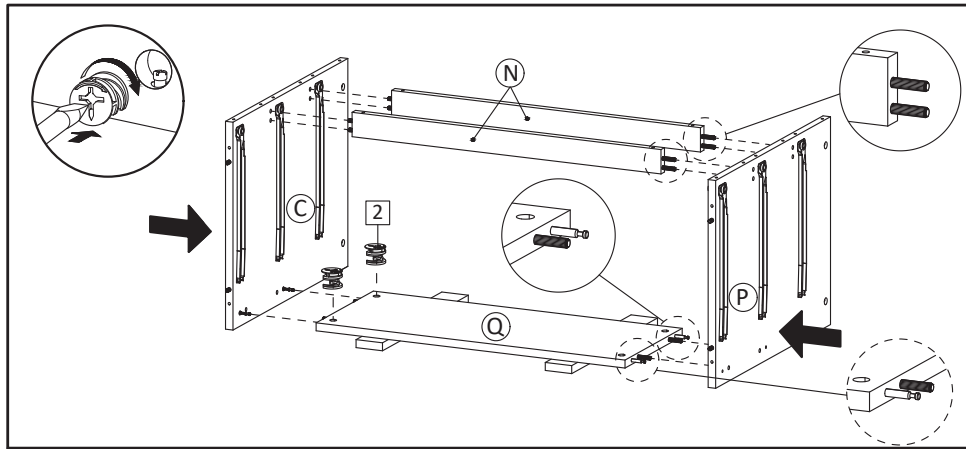

**STEP9:** Attach Side Board Left (C), Center Board (P), Support Board (N) Support Board 2 (Q). Secure with Camlock Big (HW2) and tighten it using screwdriver as figure.

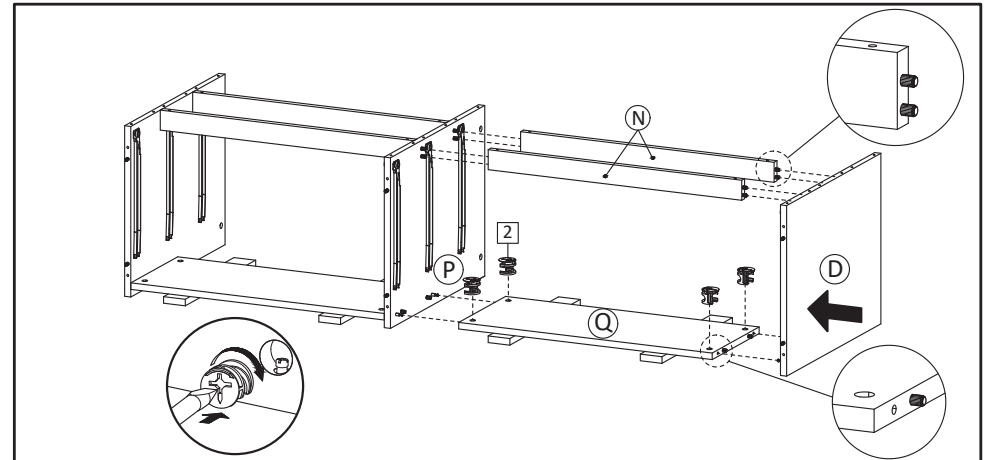

**STEP10:** Attach Side Board Right (D), Support Board (N) Support Board 2 (Q) to the Center Board from step 9. Secure with Camlock Big (HW2) and tighten it using screwdriver as figure.

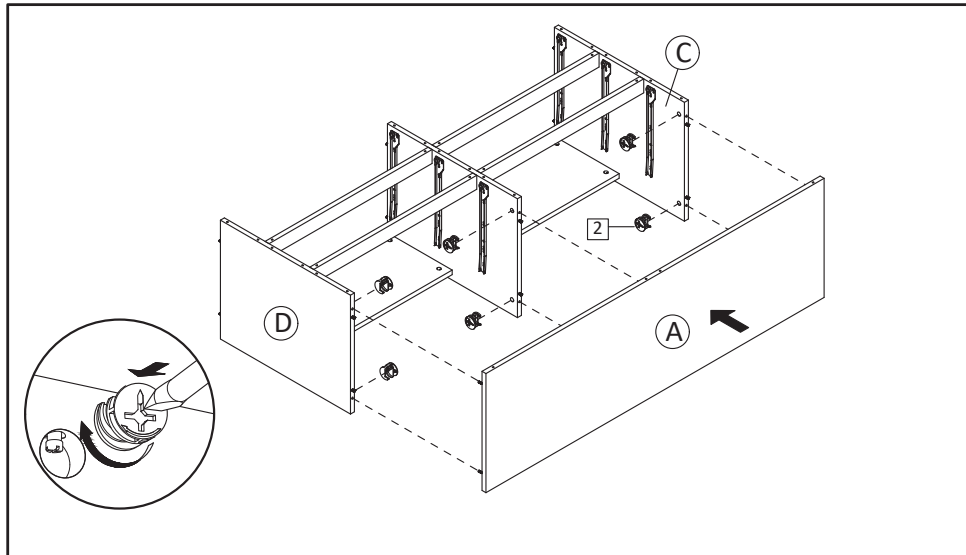

**STEP11:** Attach the Top Board (A) to the Body assembly as figure.

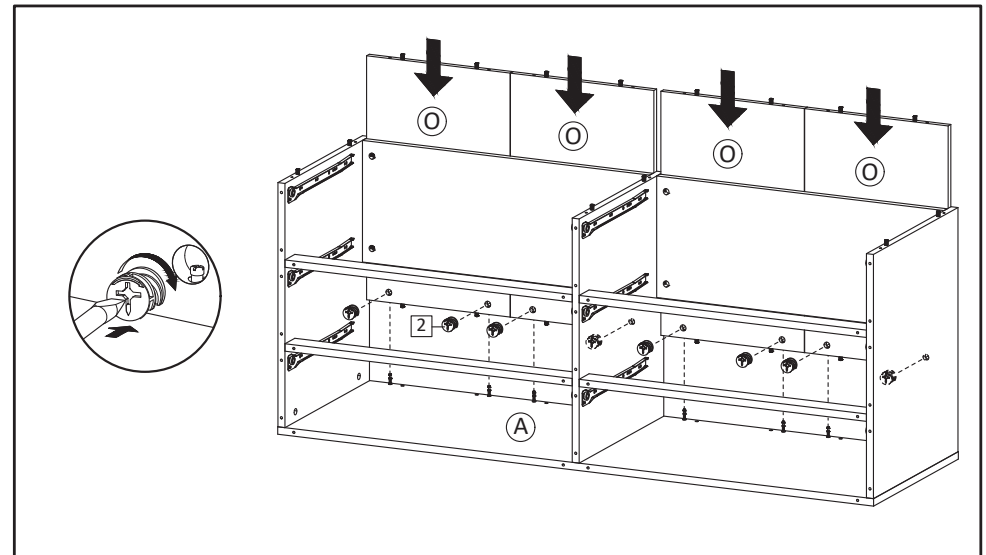

**STEP12:** Attach the Back Board (O) into Top Board (A) as figure

# PREPARATION

- \*Before beginning assembly of product, make sure all parts are present. Compare parts with part contents list and hardware contents list.
- \*If any part is missing or damaged, do not attempt to assemble the product.
- \*Estimated Assembly Time: 90 minutes.
- \*Tools Required for Assembly (included): Allen Key
- \*If you are having difficulty, our friendly Customer Care team is always here to help. Please email [customersupport@safavieh.com](mailto:customersupport@safavieh.com)

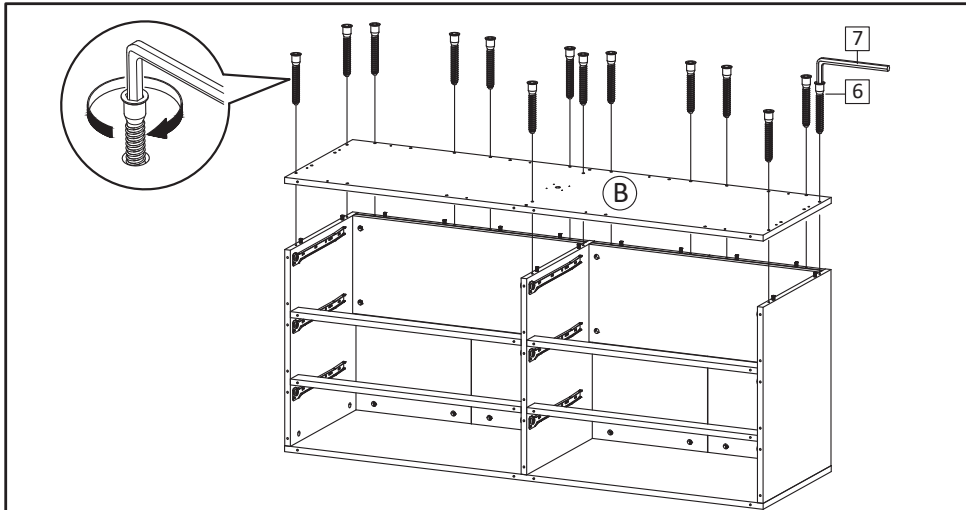

**STEP13:** Place Bottom Board (B), then secure with Screw M7x50mm (HW6), tighten screws using Allen Key (HW7).

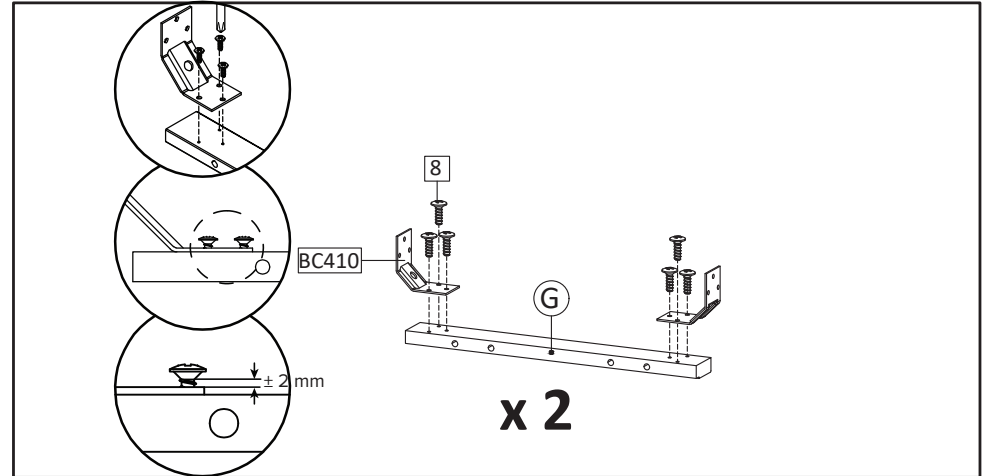

**STEP14:** Now let's combine the bottom skirt. Start with installing Corner Brace (HW BC410) into Bottom Skirt 2 (G) using Screw M4.5x12.5mm (HW8). Do not overtight screw yet, leave around 2mm gap.

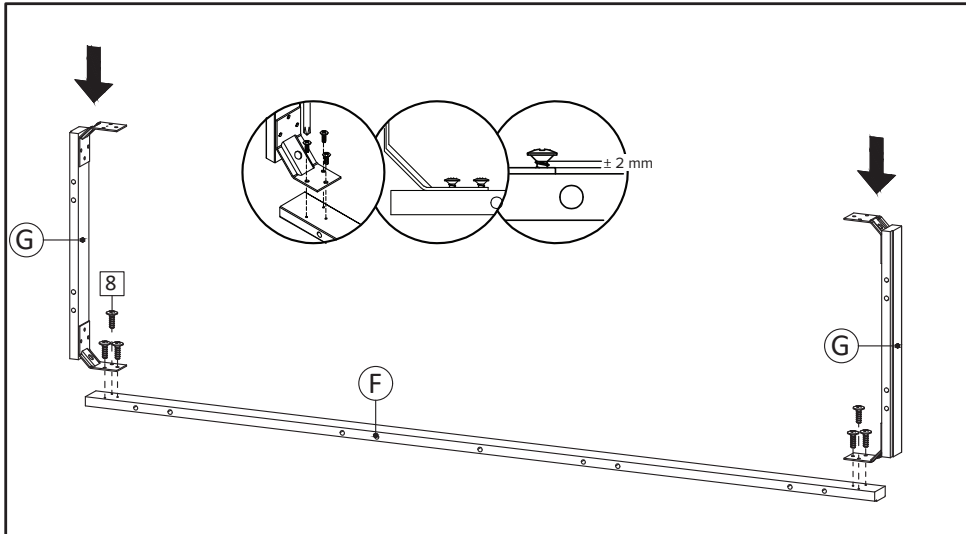

**STEP15:** Combine the Bottom Skirt 2 from step 14 with Bottom skirt 1 (F), using Screw M4.5x12.5mm (HW8). Do not overtight screw yet, leave around 2mm gap.

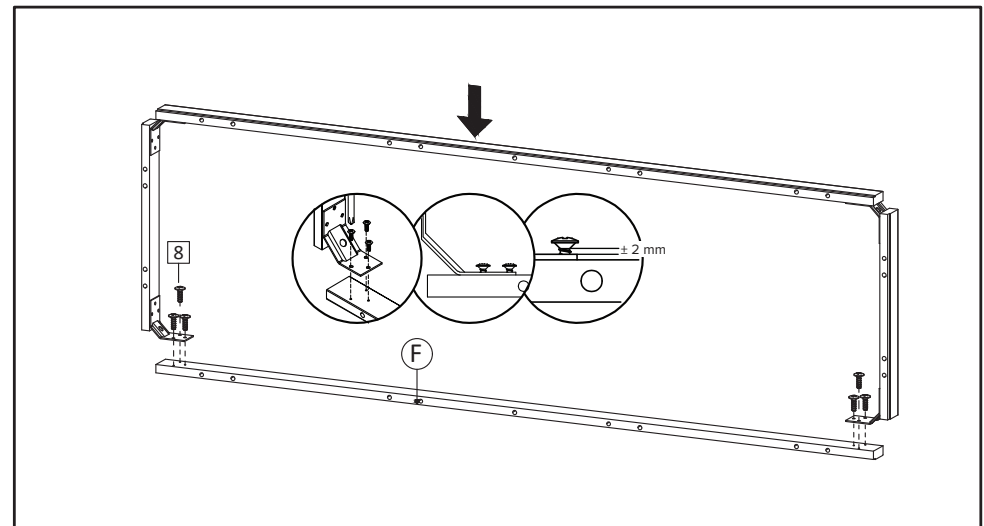

**STEP16:** Combine components from step 15 with remaining Bottom skirt 1 (F), using M4.5x12.5mm (HW8). Do not overtight screw yet, leave around 2mm gap.

# PREPARATION

\*Before beginning assembly of product, make sure all parts are present. Compare parts with part contents list and hardware contents list.

\*If any part is missing or damaged, do not attempt to assemble the product.

\*Estimated Assembly Time: 90 minutes.

\*Tools Required for Assembly (included): Allen Key

\*If you are having difficulty, our friendly Customer Care team is always here to help. Please email [customersupport@safavieh.com](mailto:customersupport@safavieh.com)

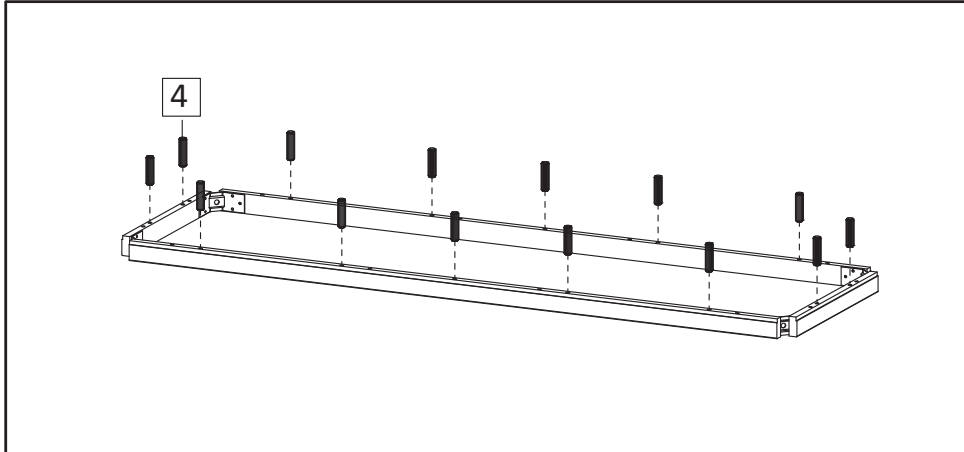

**STEP17:** Insert Dowel Middle (HW4) into assembled Bottom skirt from previous step.

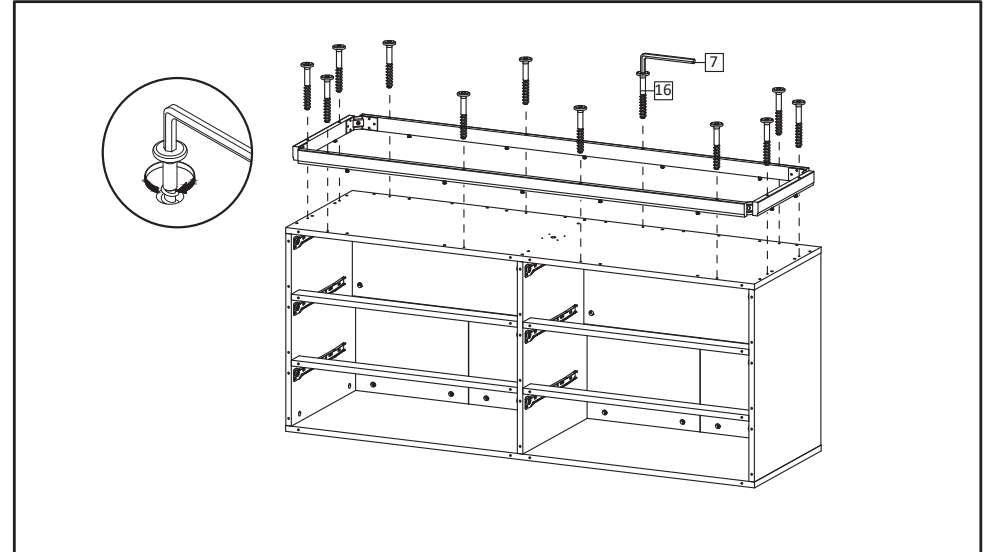

**STEP18:** Bring the assembled bottom skirt and insert into Bottom Board of the chest drawer. Secure the bottom skirt by inserting Screw M6.4x53mm (HW16) tighten with Allen Key (HW7).

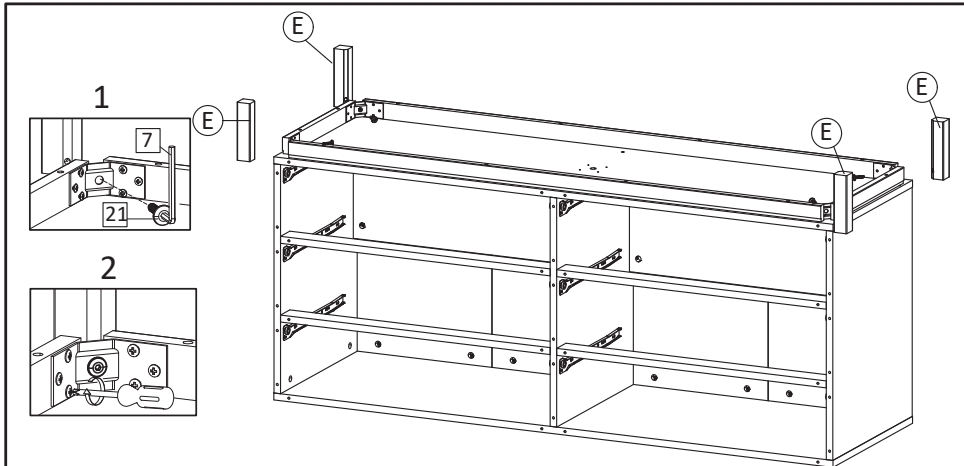

**STEP19:** Place the Leg (E) on the center corner brace and insert the screw M6x25mm (HW21) with Allen Key (HW7) into the leg, then tighten all the screws.

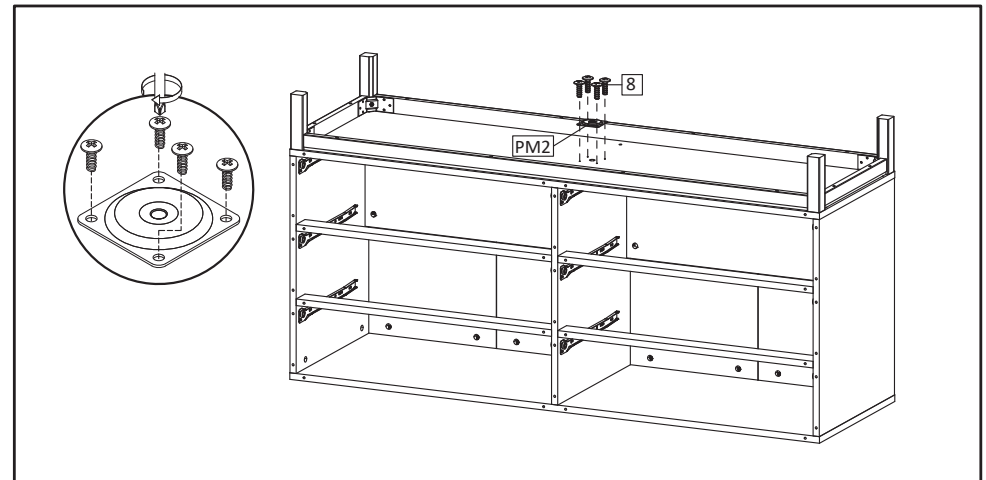

**STEP20:** Install Mounting Plate (PM2) and secure with screw M4.5x12.5mm (HW8) on Bottom Board.



# PREPARATION

\*Before beginning assembly of product, make sure all parts are present. Compare parts with part contents list and hardware contents list.

\*If any part is missing or damaged, do not attempt to assemble the product.

\*Estimated Assembly Time: 90 minutes.

\*Tools Required for Assembly (included): Allen Key

\*If you are having difficulty, our friendly Customer Care team is always here to help. Please email [customersupport@safavieh.com](mailto:customersupport@safavieh.com)

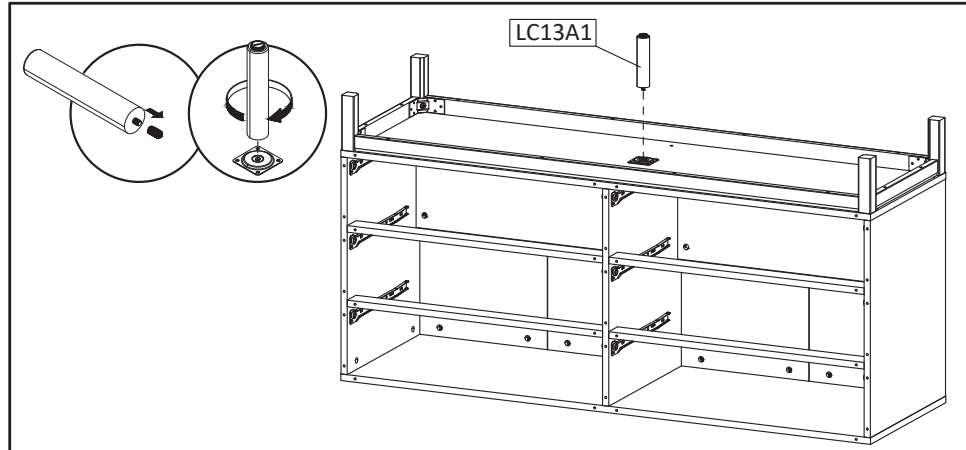

**STEP21:** Insert Center Leg (LC13A1) into Mounting Plate by rotating clockwise until tightened.

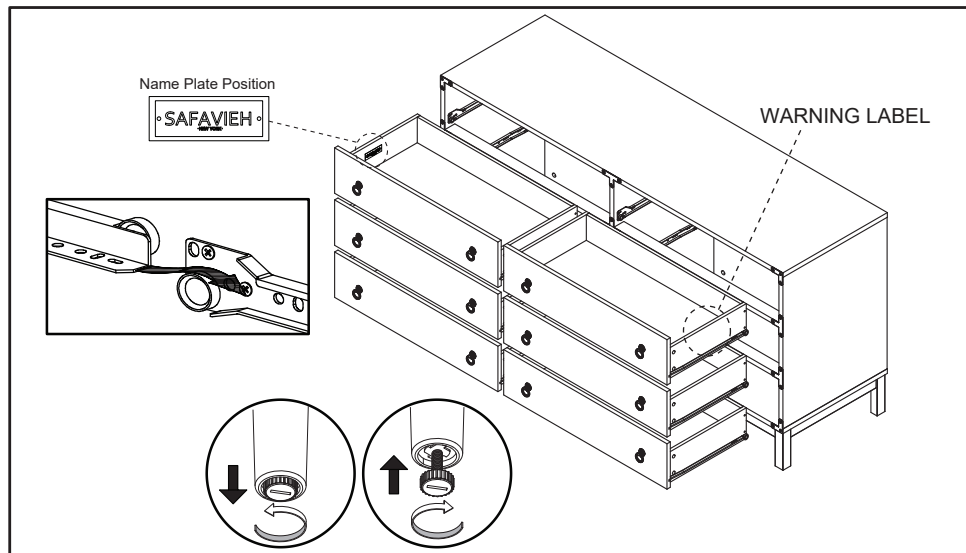

**STEP23:** Hold the sides of drawer, position the wheel of rail at drawer back and the wheel of rail at side boards, according to the image. Slide in the drawers one by one into the chest drawer. Place your furniture on level floor. The legs come with adjustable leveller, adjust it as needed until your furniture sit steady on the floor.

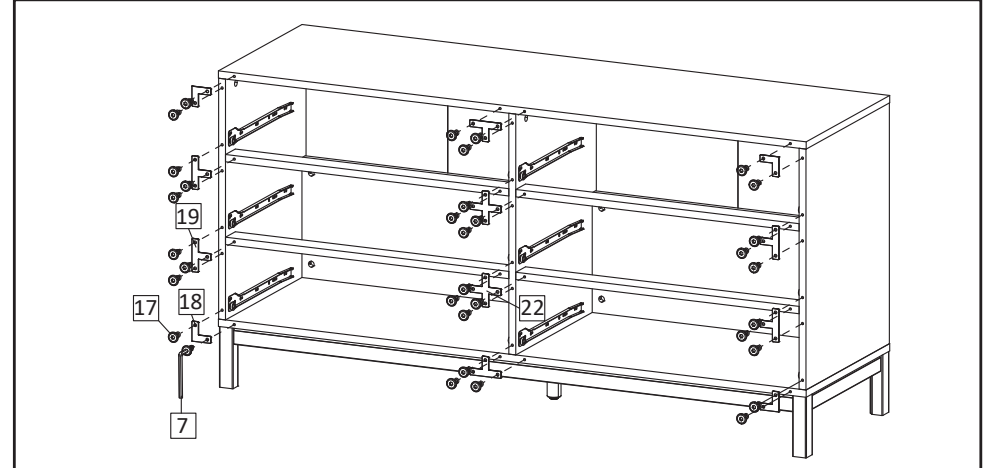

**STEP22:** Bring the chest drawer upright, Install Plat L (HW18), Plat T (HW19) and Plat + (HW22) into the provided holes at front edges of the chest drawer. Secure with screw M6.4x14mm (HW17), tighten using Allen Key (HW7).

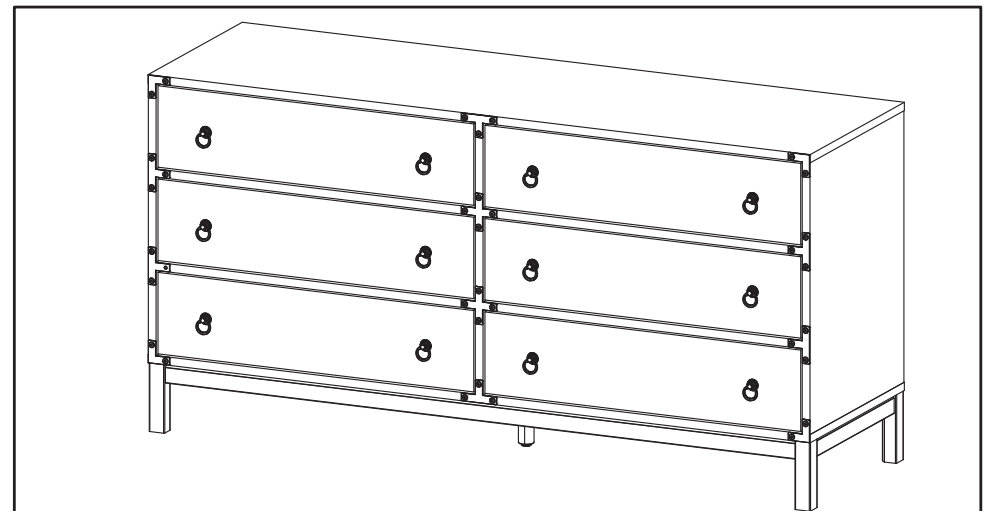

**STEP24:** Assembly is complete.

# TIPPING RESTRAINTS KIT INSTALLATION GUIDANCE

Different wall materials require unique wall fasteners.

The wall plugs (AA2) and screws (AA3) are designed for fixing to concrete walls only.

Please consult your local hardware store to ensure you are using the correct hardware for your wall type.

