











CARE AND MAINTENANCE

Spot clean using a mild water-free solvent. Only a professional cleaner should undertake a complete overall cleaning.
The use of steam or water-based cleaners may cause excessive shrinking or staining.

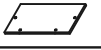
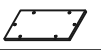
NOTICE

- * Please make sure that you have all parts indicated before you begin assembly of this item.
- * This item should be assembled on a soft surface to prevent scratching the finish during assembly.
- * This item may require periodic tightening.

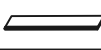
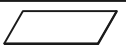
Part List and Hardware List

PIECE	DESCRIPTION	PICTURE	QUANTITY
A	TOP PANEL		1X
B	LEFT PANEL		1X
C	RIGHT PANEL		1X
D	FRAME		2X
E	BOTTOM PANEL		1X
F	SIDE BACK PANEL		2X
G	CENTER BACK PANEL		1X
H	LEG		4X
I	UPPER DRAWER FRONT		1X
J	DRAWER LEFT		3X
K	DRAWER RIGHT		3X
L	DRAWER BACK		3X
M	DRAWER BASE		3X
N	DRAWER SUPPORT		3X
O	LOWER DRAWER FRONT		2X

SAFAVIEH FURNITURE





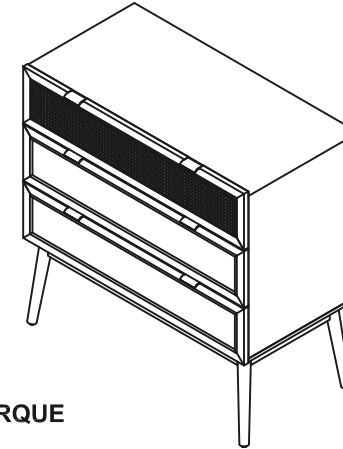





Model# CHS5000A

Product Dimensions: 36"W x 18"D x 36"H



WEIGHT CAPACITY :
TOP : 110 LBS
DRAWER : 30 LBS

**WARNING: DO NOT OVER TORQUE
BOLTS/SCREWS**

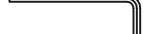
PIECE	DESCRIPTION	PICTURE	QUANTITY
1	BOLT	M6x65mm 	8X
2	SPRING WASHER		8X
3	FLAT WASHER		8X
4	1 1/4" FLAT HEAD SCREW	M3x32mm 	33X
5	3/4" FLAT HEAD SCREW	M3x19mm 	18X
6	1/2" FLAT HEAD SCREW	M3x13mm 	12X
7	CAMBOLT		34X
8	CAMLOCK		34X
9	HANDLE		6X
10	WOODEN DOWEL		8X
11	ALLEN KEY		1X

PREPARATION

Before beginning assembly of product, make sure all parts are present. Compare parts with package contents list and hardware contents list.

If any part is missing or damaged, do not attempt to assemble the product.

Estimated Assembly Time: 60 minutes.

Tools Required for Assembly : Phillips Screwdriver

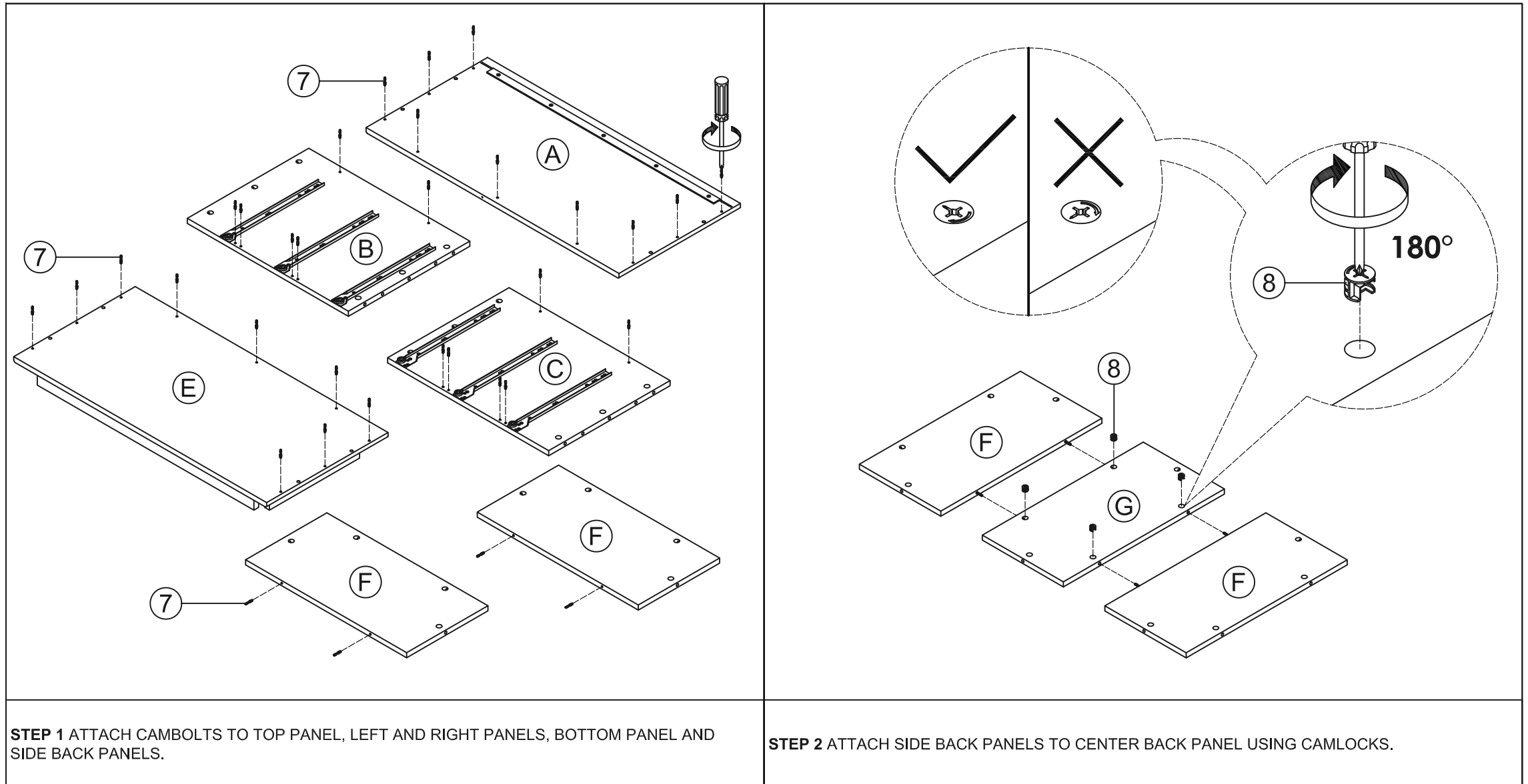

PREPARATION

Before beginning assembly of product, make sure all parts are present. Compare parts with package contents list and hardware contents list.

If any part is missing or damaged, do not attempt to assemble the product.

Estimated Assembly Time: 60 minutes.

Tools Required for Assembly : Phillips Screwdriver

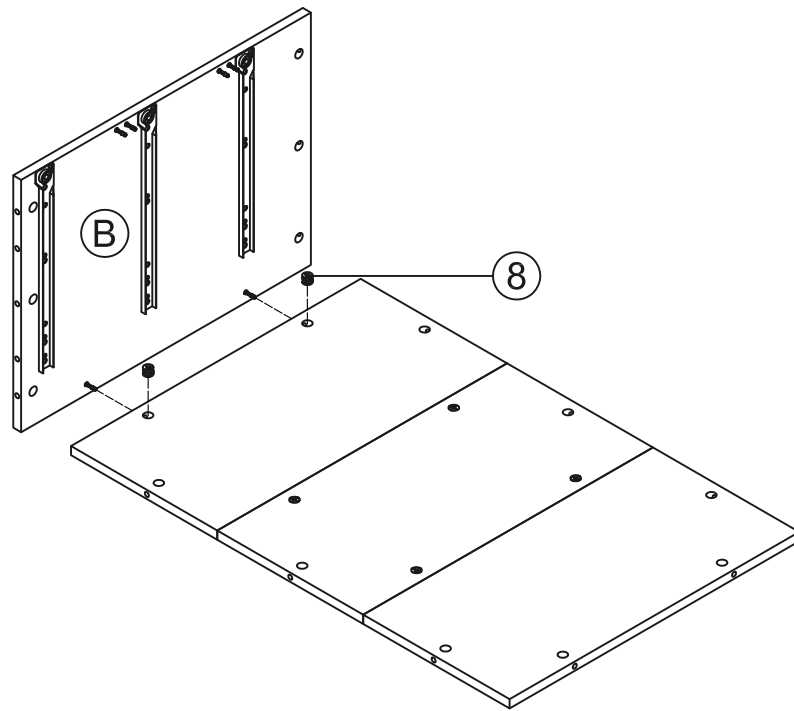

STEP 3 ATTACH LEFT PANEL TO UNIT USING CAMLOCKS.

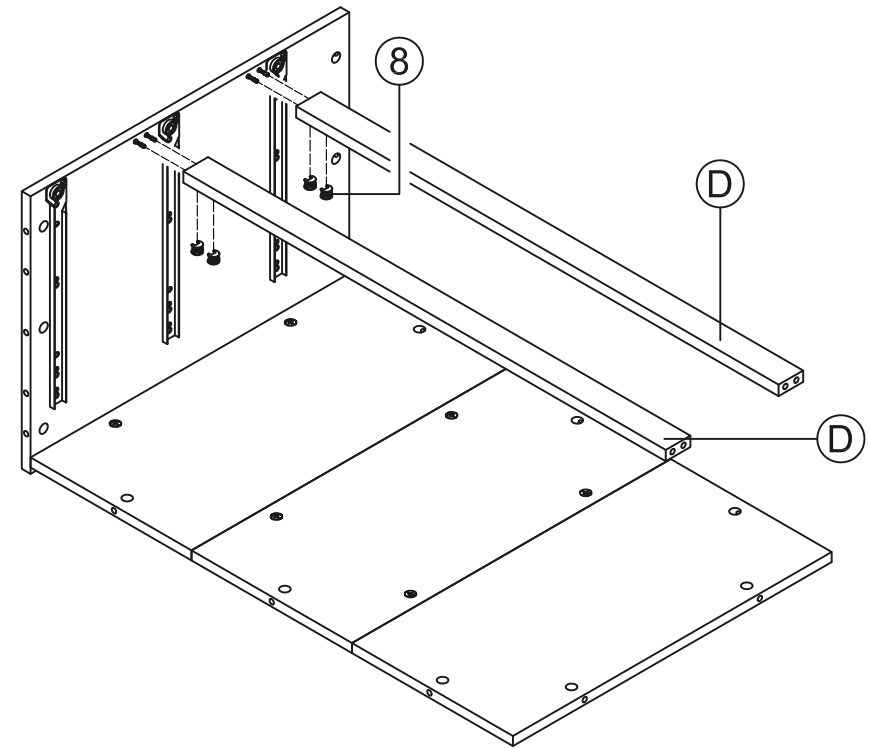

STEP 4 ATTACH FRAMES TO UNIT USING CAMLOCKS.

PREPARATION

Before beginning assembly of product, make sure all parts are present. Compare parts with package contents list and hardware contents list.

If any part is missing or damaged, do not attempt to assemble the product.

Estimated Assembly Time: 60 minutes.

Tools Required for Assembly : Phillips Screwdriver

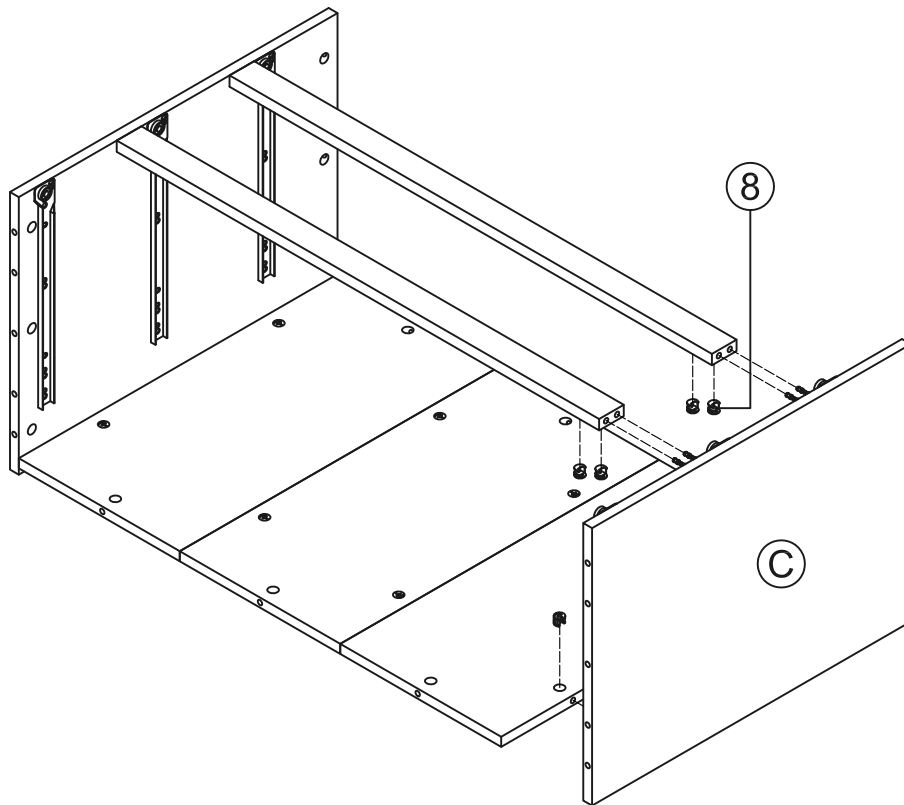

STEP 5 ATTACH RIGHT PANEL TO UNIT USING CAMLOCKS.

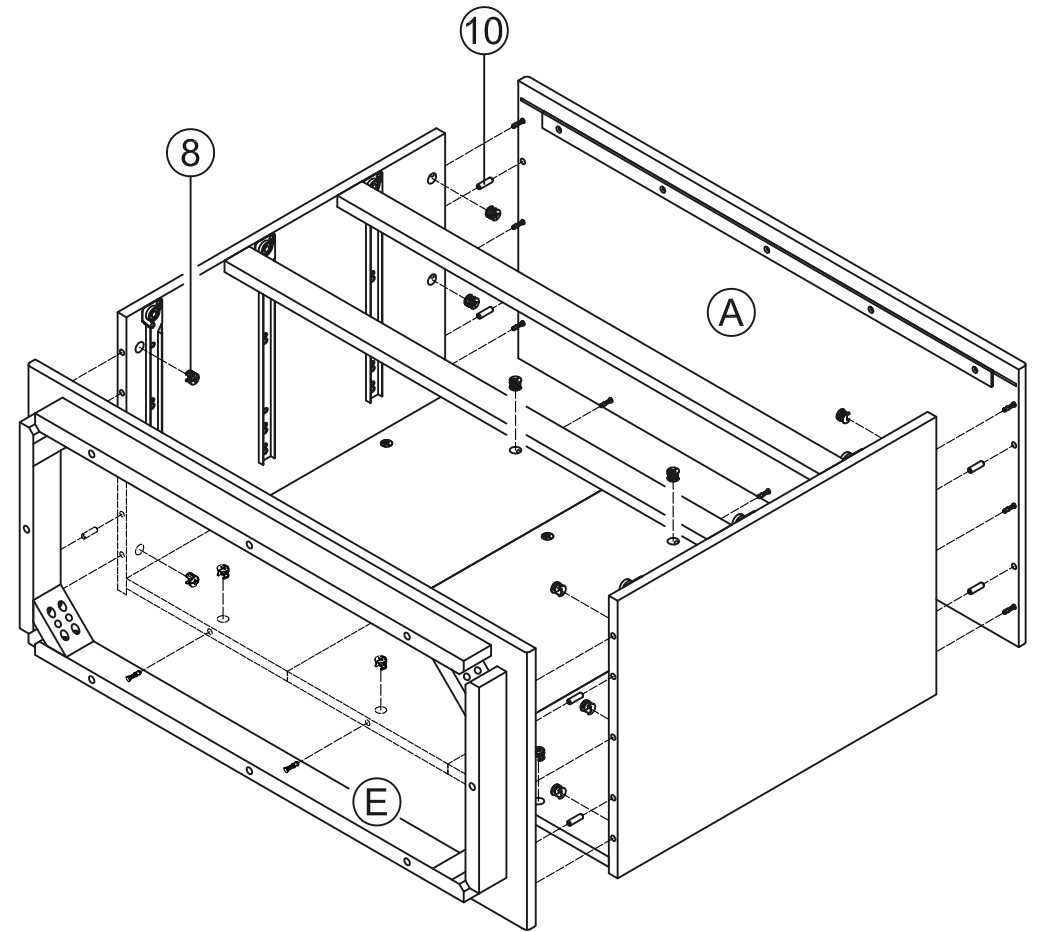

STEP 6 ATTACH TOP AND BOTTOM PANELS TO UNIT USING CAMLOCKS AND WOODEN DOWELS.

PREPARATION

Before beginning assembly of product, make sure all parts are present. Compare parts with package contents list and hardware contents list.

If any part is missing or damaged, do not attempt to assemble the product.

Estimated Assembly Time: 60 minutes.

Tools Required for Assembly : Phillips Screwdriver

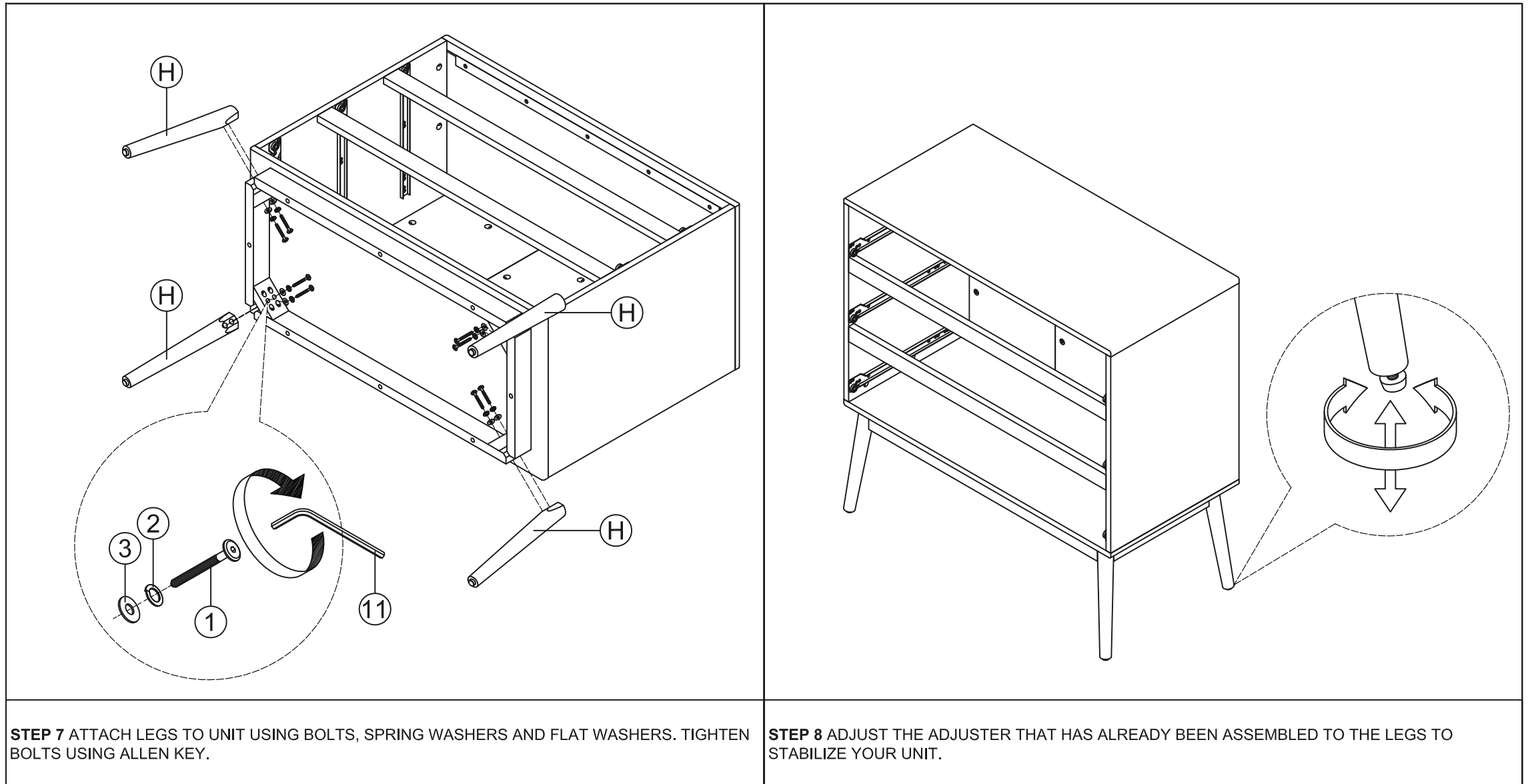

STEP 7 ATTACH LEGS TO UNIT USING BOLTS, SPRING WASHERS AND FLAT WASHERS. TIGHTEN BOLTS USING ALLEN KEY.

STEP 8 ADJUST THE ADJUSTER THAT HAS ALREADY BEEN ASSEMBLED TO THE LEGS TO STABILIZE YOUR UNIT.

PREPARATION

Before beginning assembly of product, make sure all parts are present. Compare parts with package contents list and hardware contents list.

If any part is missing or damaged, do not attempt to assemble the product.

Estimated Assembly Time: 60 minutes.

Tools Required for Assembly : Phillips Screwdriver

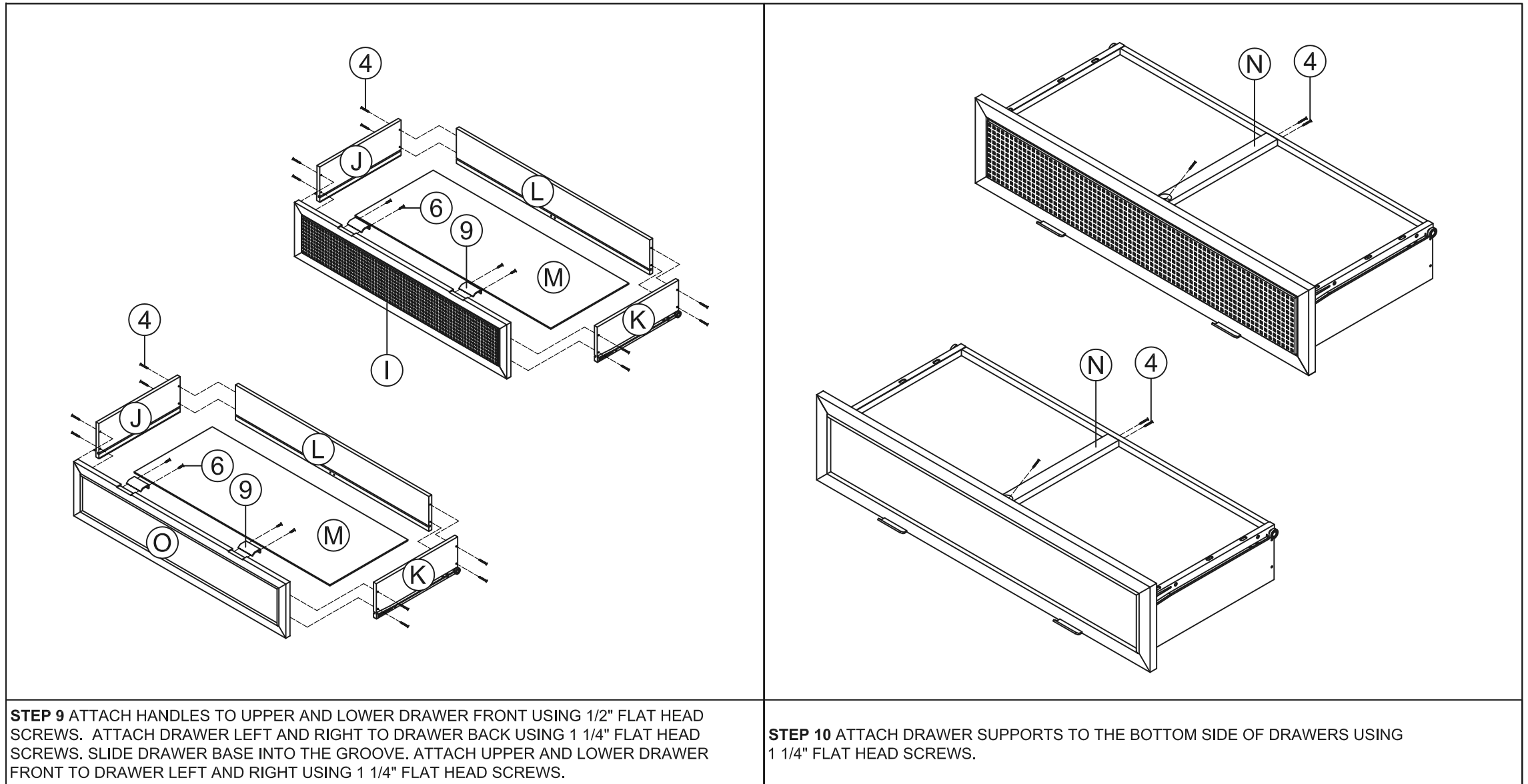

PREPARATION

Before beginning assembly of product, make sure all parts are present. Compare parts with package contents list and hardware contents list.

If any part is missing or damaged, do not attempt to assemble the product.

Estimated Assembly Time: 60 minutes.

Tools Required for Assembly : Phillips Screwdriver

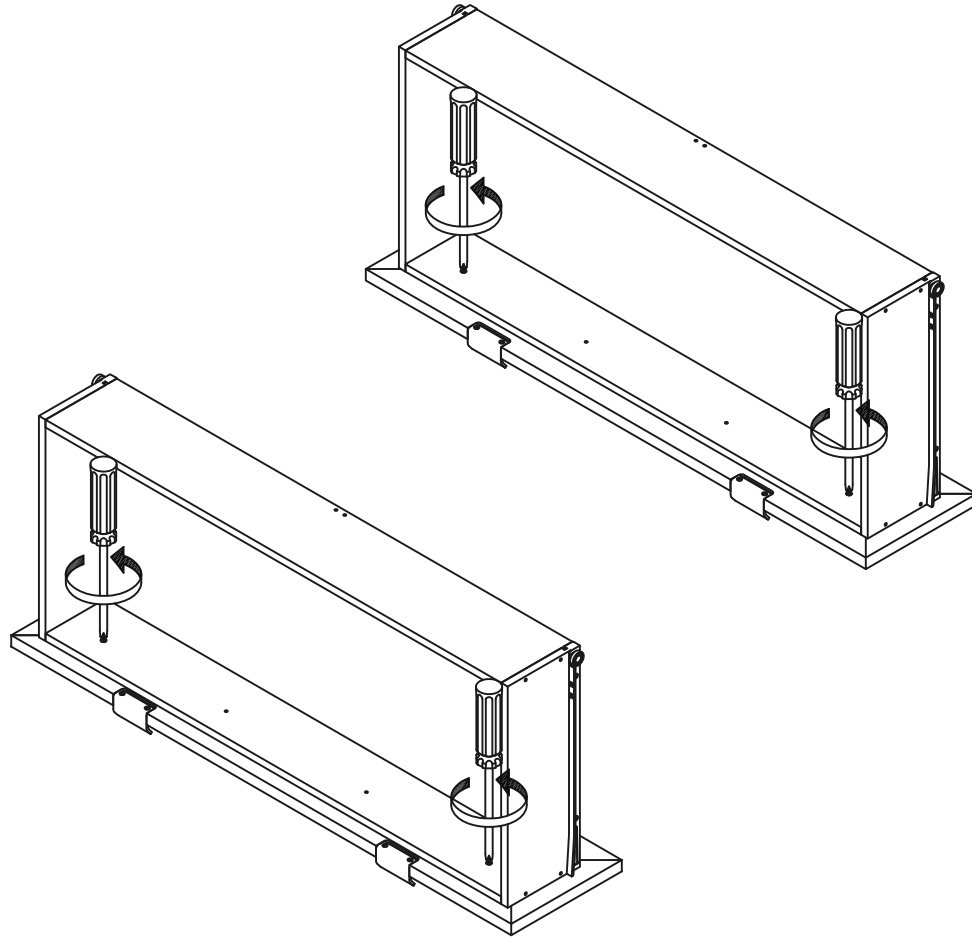

STEP 11 LOOSEN SLIGHTLY THE SCREWS PRE-INSTALLED ON THE BACK OF THE UPPER AND LOWER DRAWER FRONTS.

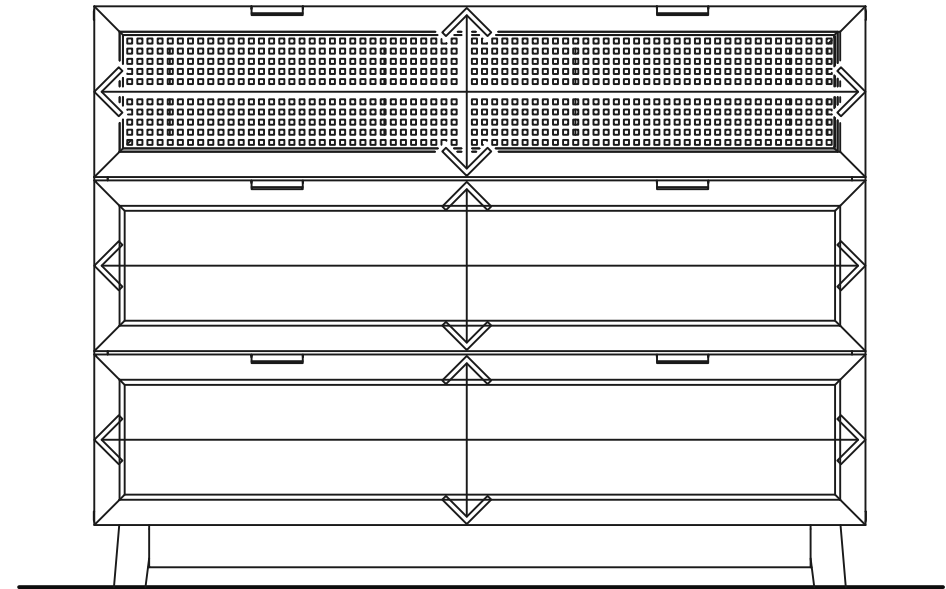

STEP 12 INSERT THE DRAWER INTO THE UNIT, THEN ADJUST THE DRAWER FRONT PANEL LEFT OR RIGHT AND UP OR DOWN UNTIL THE DRAWER GAPS LOOK PROPORTIONAL.

PREPARATION

Before beginning assembly of product, make sure all parts are present. Compare parts with package contents list and hardware contents list.

If any part is missing or damaged, do not attempt to assemble the product.

Estimated Assembly Time: 60 minutes.

Tools Required for Assembly : Phillips Screwdriver

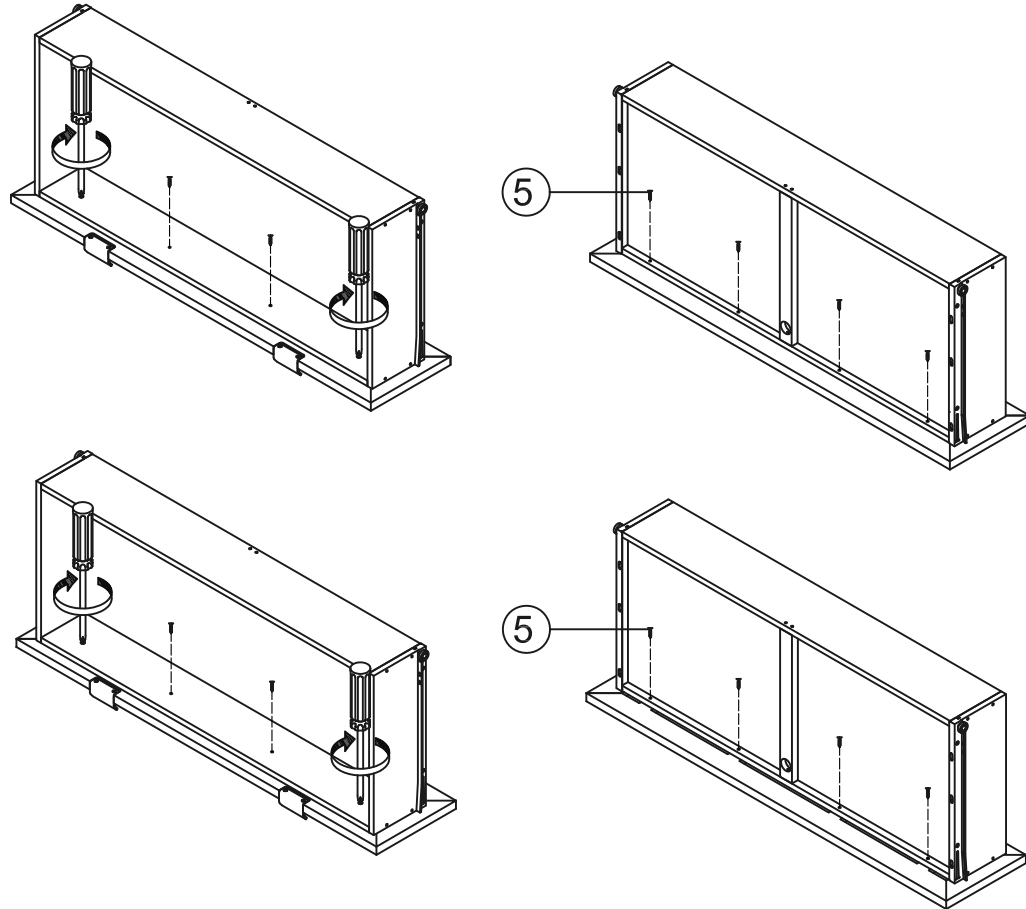

STEP 13 PULL THE DRAWER OPEN SLOWLY AND RE-TIGHTEN THE SCREWS FROM STEP 11. MAKE SURE THE FRONT PANEL DOES NOT MOVE AND LOCK THE DRAWER FRONT PANEL INTO POSITION WITH 3/4" FLAT HEAD SCREWS.

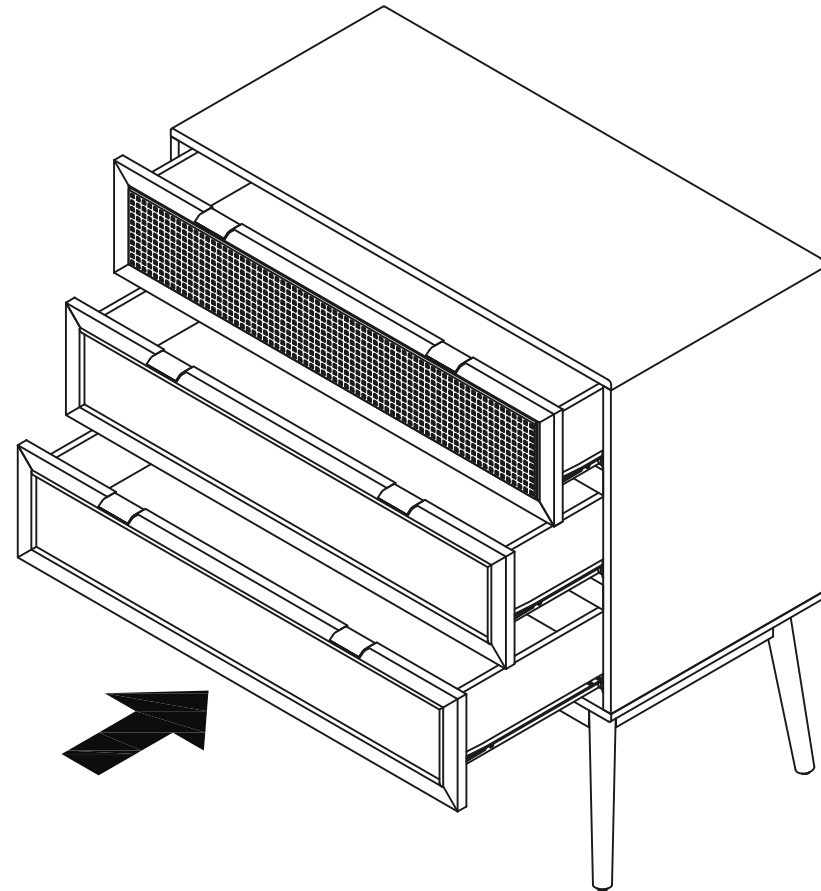

STEP 14 SLIDE THE DRAWERS INTO UNIT.