

## CARE AND MAINTENANCE

Always use felt pads under all articles to prevent discoloration or softening of the lacquer. Plastic and rubber bases on items can discolor wood. Wipe up spills immediately and avoid common hazards such as hot dishes, harsh solvents and abrasives. Cleaning should be done with a soft lint free cotton cloth dampened with water or furniture polish. On highly used surfaces we recommend applying a quality paste wax which should be used on a regular basis to provide additional protection from scratches and spills. How often you apply the wax depends on how much wear the furniture receives.





















## NOTICE

\* Please make sure that you have all parts indicated before you begin assembly of this item

\* This item should be assembled on a soft surface to prevent scratching the finish during assembly

\* This item may require periodic tightening

## Part List and Hardware List

PIECE	DESCRIPTION	PICTURE	QUANTITY
A	HEADBOARD		1X
B	WOODEN LEG		2X
C	BOLT 8X40		6X
D	WASHER M8		6X
E	RING M8		6X
F	BOLT 8X60		4X
G	WASHER M8		4X
H	RING M8		4X
I	ALLEN KEY		1X
J	L-RAIL		2X
K	R-RAIL		2X
L	FOOTBOARD		1X
M	SIDERAIL LEGS		2X
N	SLATS		3X
O	SUPPORT LEGS		6X
P	IRON PLATE		2X
Q	SCREW 6X1		8X
R	SCREW 6X1 1/4		4X
S	SCREW 6X1 3/4		6X
T	WRENCH		1X

 **SAFAVIEH**  
FURNITURE

Model # BED8002-F

Product Dimensions :58"W x 83"D x 54"H

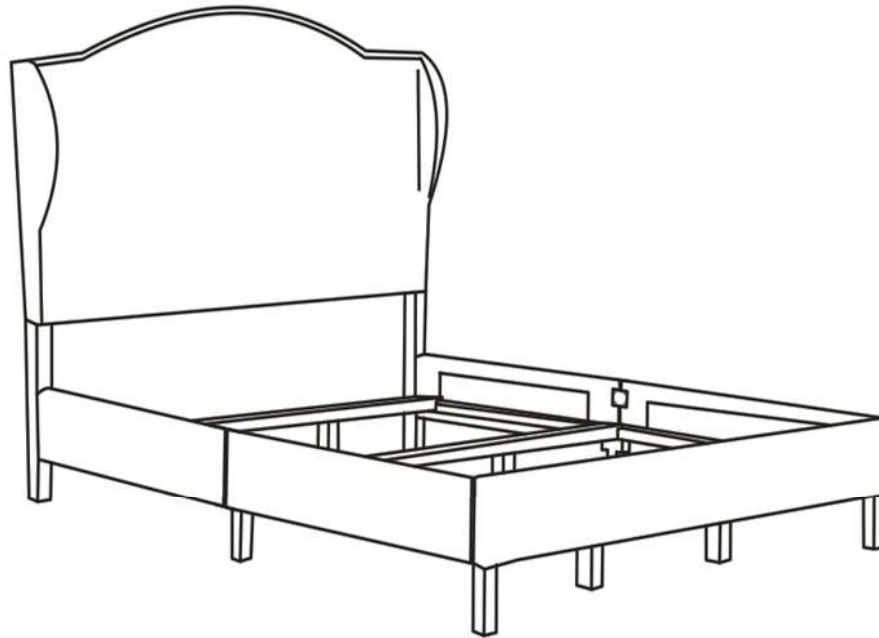

## PREPARATION

Before beginning assembly of product, make sure all parts are present. Compare parts with package contents list and hardware contents list.

If any part is missing or damaged, do not attempt to assemble the product.

Estimated Assembly Time: 10 minutes.

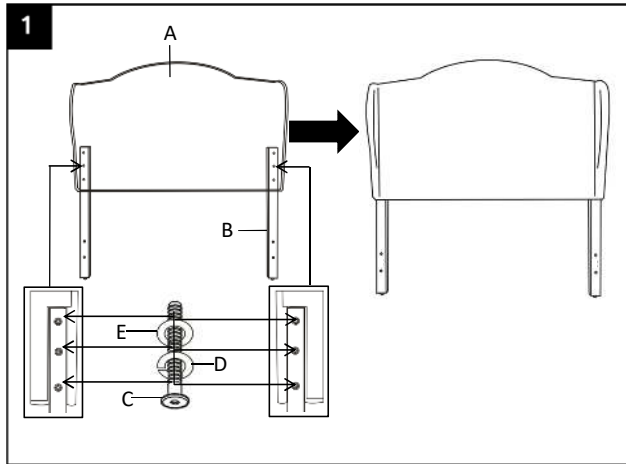

### Step 1

The hardware needed to connect the legs (B) to the headboard (A) are bolt (C), washer (D) and ring (E)  
Attach the two legs (B) to the headboard (A) using 6 bolts (C), 6 washers and 6 rings. Others 6 bolts, washers and rings are attached on

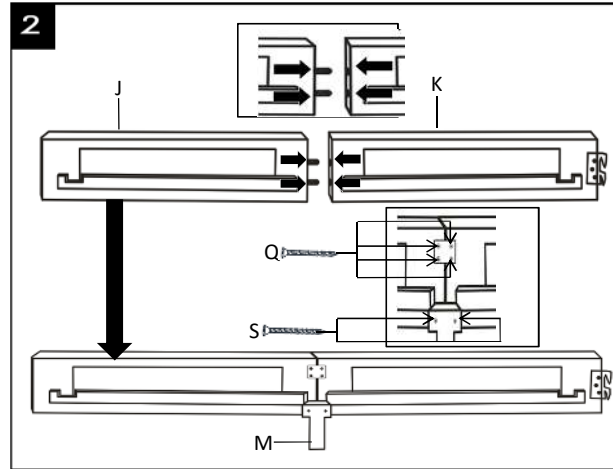

### Step 2

Joint the 2 siderails (J) & (K). Using screw driver (not included) to lock with screws (Q).  
Attach siderail leg (M) to the 2 rails (J) & (K). Using screw driver (not included) to lock with another screws @.

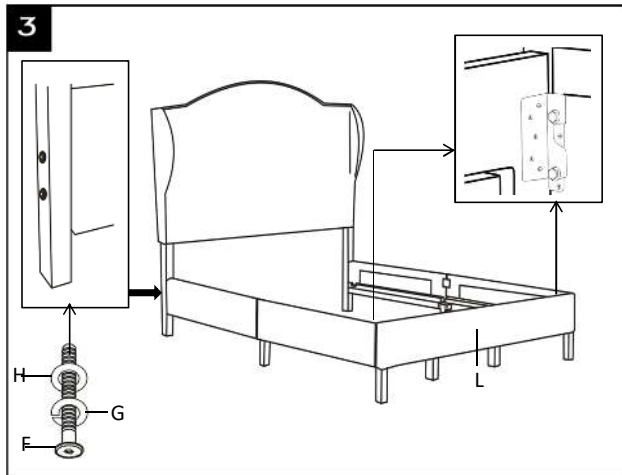

### Step 3

Attach 2 siderails to the headboard (A) assembled with wooden legs (B) a footboard (L)  
Tightened the bolts in wooden legs using Allen Key.  
Tightened the bolts in footboard corners using wrench.

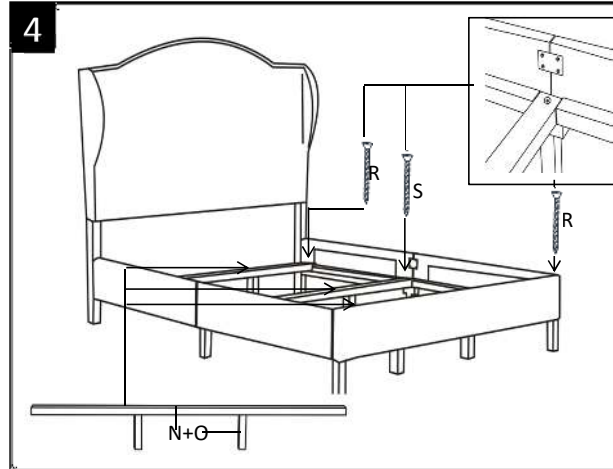

### Step 4

Attach 2 support legs (O) to each slats (N).  
Attach slats to the siderails support.

## CARE AND MAINTENANCE

Always use felt pads under all articles to prevent discoloration or softening of the lacquer. Plastic and rubber bases on items can discolor wood. Wipe up spills immediately and avoid common hazards such as hot dishes, harsh solvents and abrasives. Cleaning should be done with a soft lint free cotton cloth dampened with water or furniture polish. On highly used surfaces we recommend applying a quality paste wax which should be used on a regular basis to provide additional protection from scratches and spills. How often you apply the wax depends on how much wear the furniture receives.





















## NOTICE

\* Please make sure that you have all parts indicated before you begin assembly of this item

\* This item should be assembled on a soft surface to prevent scratching the finish during assembly

\* This item may require periodic tightening

## Part List and Hardware List

PIECE	DESCRIPTION	PICTURE	QUANTITY
A	HEADBOARD		1X
B	WOODEN LEG		2X
C	BOLT 8X40		6X
D	WASHER M8		6X
E	RING M8		6X
F	BOLT 8X60		4X
G	WASHER M8		4X
H	RING M8		4X
I	ALLEN KEY		1X
J	L-RAIL		2X
K	R-RAIL		2X
L	FOOTBOARD		1X
M	SIDERAIL LEGS		2X
N	SLATS		3X
O	SUPPORT LEGS		6X
P	IRON PLATE		2X
Q	SCREW 6X1		8X
R	SCREW 6X1 1/4		4X
S	SCREW 6X1 3/4		6X
T	WRENCH		1X

 **SAFAVIEH**  
FURNITURE

Model # BED8002-Q

Product Dimensions :63"W x 83"D x 54"H

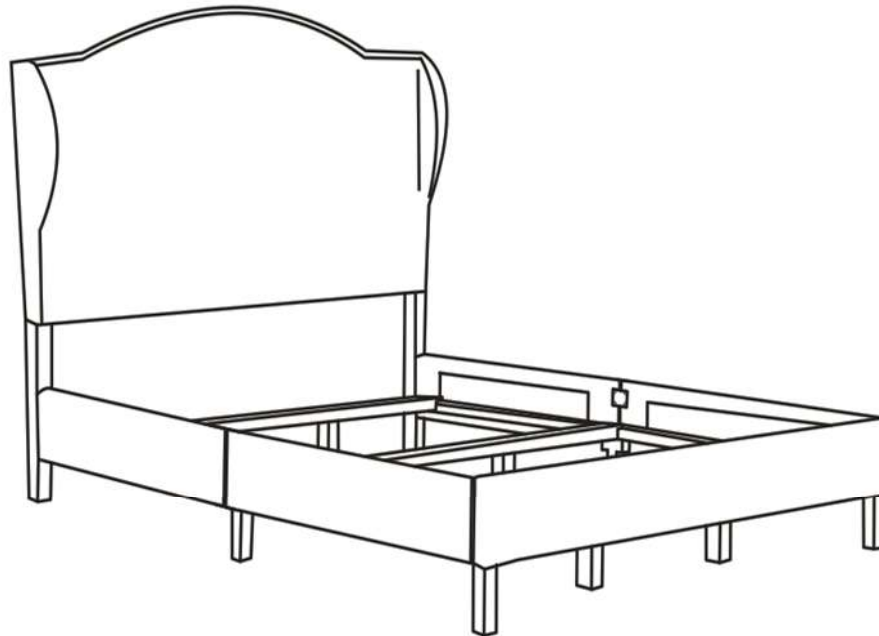

## PREPARATION

Before beginning assembly of product, make sure all parts are present. Compare parts with package contents list and hardware contents list.

If any part is missing or damaged, do not attempt to assemble the product.

Estimated Assembly Time: 10 minutes.

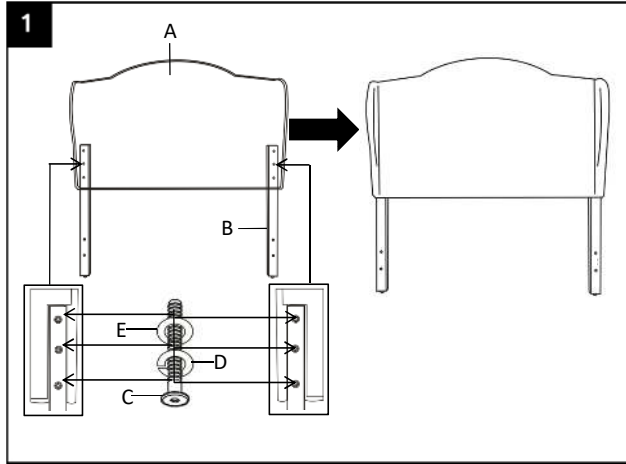

### Step 1

The hardware needed to connect the legs (B) to the headboard (A) are bolt (C), washer (D) and ring (E)  
Attach the two legs (B) to the headboard (A) using 6 bolts (C), 6 washers and 6 rings. Others 6 bolts, washers and rings are attached on

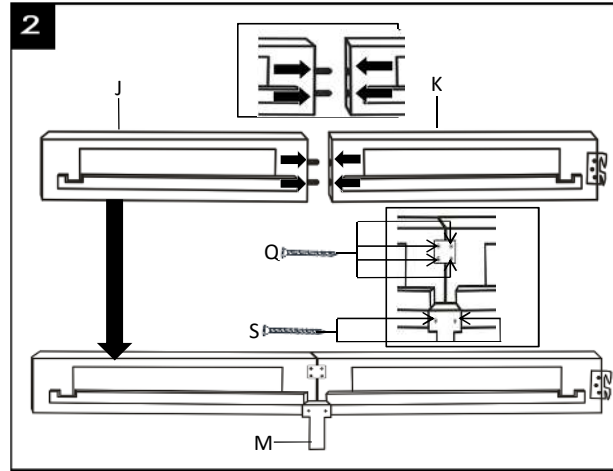

### Step 2

Join the 2 siderails (J) & (K). Using screw driver (not included) to lock with screws (Q).  
Attach siderail leg (M) to the 2 rails (J) & (K). Using screw driver (not included) to lock with another screws (S).

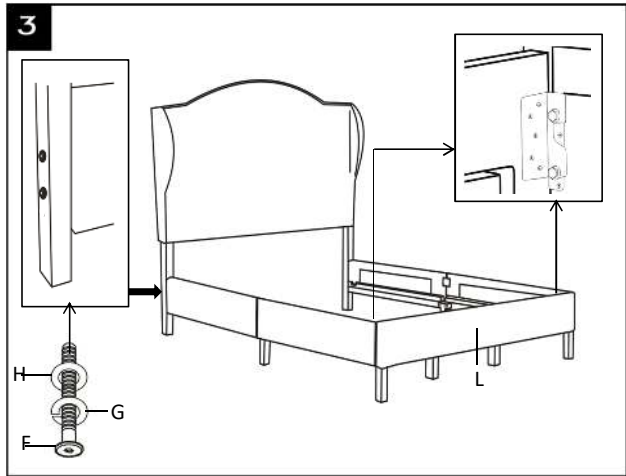

### Step 3

Attach 2 siderails to the headboard (A) assembled with wooden legs (B) a footboard (L)  
Tightened the bolts in wooden legs using Allen Key.  
Tightened the bolts in footboard corners using wrench.

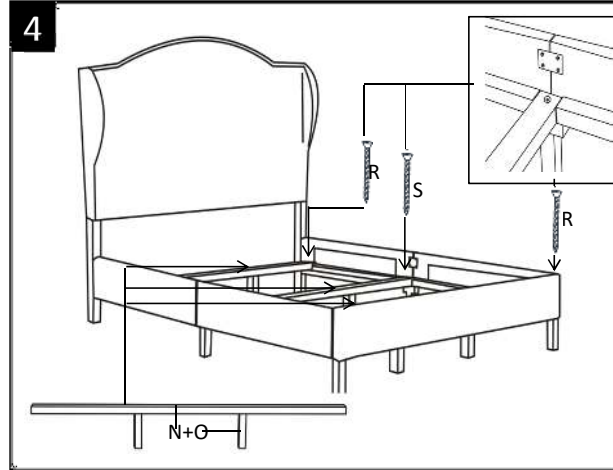

### Step 4

Attach 2 support legs (O) to each slats (N).  
Attach slats to the siderails support.