

## NOTICE

- \*Please make sure that you have all parts indicated and they are in good condition before you begin assembly of this item.Refer to parts list and hardware list below for guidance.
- \*This item should be assembled on a soft surface to prevent scratching the finished goods during assembly.
- \* This item may require periodic tightening.
- \* If you are having difficulty, our friendly Customer Care team is always here to help. Please email [customersupport@safavieh.com](mailto:customersupport@safavieh.com)

## PREPARATION

- \*Before beginning assembly of product,make sure all parts are present.Compare parts with part contents list and hardware contents list.
- \*If an part is missing or damaged,do not attempt to assemble the product.
- \*Estimated Assembly Time:20 minutes.
- \*Tools Required for Assembly (included):Allen Key.

## CARE AND MAINTENANCE

### INDOOR METAL/ALUMINUM FURNITURE

Wipe spills immediately. Maintain with regular dusting and clean with mild soap and water, dry thoroughly and do not use a brass cleaner. Adhesive felt pads should always be used/applied in order to prevent damage to the furniture or surfaces on which the furniture is placed.

### UPHOLSTERY CARE

To prevent overall soiling, frequent vacuuming or light brushing is recommended. Down-filled cushions should be brushed rather than vacuumed. Spot clean, using a mild water-free solvent or dry cleaning product. Only a professional cleaner should undertake a complete overall cleaning. The use of steam or water-based cleaners may cause excessive shrinking or staining.

# SAFAVIEH FURNITURE

Model# BCH6203

Product Dimensions: 46"Wx18"Dx18"H

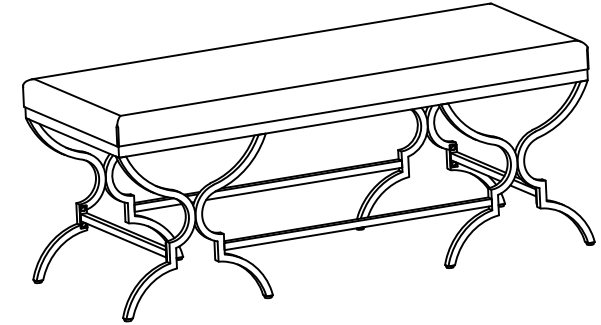

Weight capacity : 550 lbs  
**WARNING : DO NOT STAND ON THE PRODUCT**  
**WARNING : DO NOT OVER TORQUE BOLTS**

## Part List and Hardware List

PIECE	DESCRIPTION	PICTURE	QUANTITY	PIECE	DESCRIPTION	PICTURE	QUANTITY
A	Seat Cushion		1x	HW1	Hex Socket Bolt	1/4"-20 x 0.625"	16x
B	Left Side Frame		2x	HW2	Hex Socket Bolt	1/4"-20 x 1.5"	4x
C	Right Side Frame		2x	HW3	Allen Key	M4	1x
D	Long Connecting Bar		2x				
E	Short Connecting Bar		2x				

## PREPARATION

- \*Before beginning assembly of product, make sure all parts are present. Compare parts with part contents list and hardware contents list.
- \*If any part is missing or damaged, do not attempt to assemble the product.
- \*Estimated Assembly Time: 20 minutes.
- \*Tools Required for Assembly (included): Allen Key.
- \*If you are having difficulty, our friendly Customer Care team is always here to help. Please email [customersupport@safavieh.com](mailto:customersupport@safavieh.com)

1

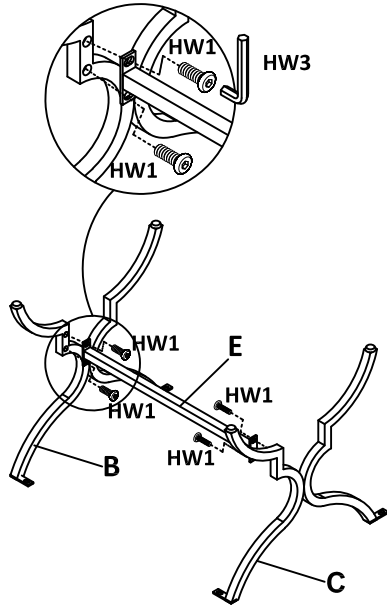

\*Do not fully tighten the bolts until the product is assembled.

### Step 1:

\*\*insure all screw holes on side frame (B&C) are facing inward.\*\* Attach the Short Connecting Bar (E) on L/R Side Frame (B/C). Use the Allen Key (HW3) to screw in the Hex Socket Bolts (HW1) into the Side Frames. See image above. (Repeat the same process for the second side frame)

2

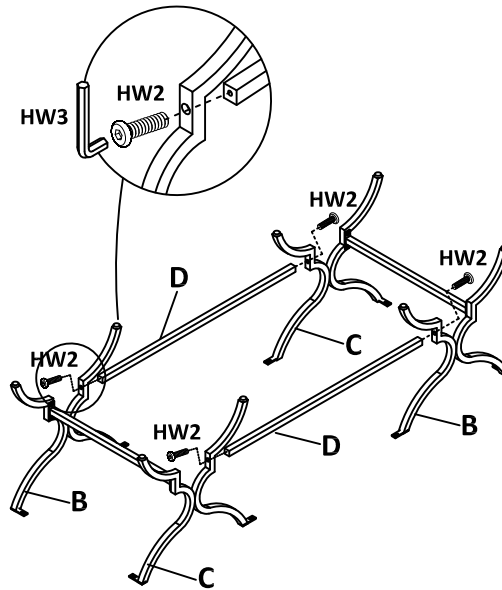

\*Do not fully tighten the bolts until the product is assembled.

### Step 2:

\*\*insure all screw holes on side frame (B&C) are facing inward.\*\* Attach 2\*Long Connecting Bar (D) on assembled L/R Side Frame (B/C), Use the Allen Key (HW3) to screw in the Hex Socket Bolts (HW2) into the Side Frames. See image above.

3

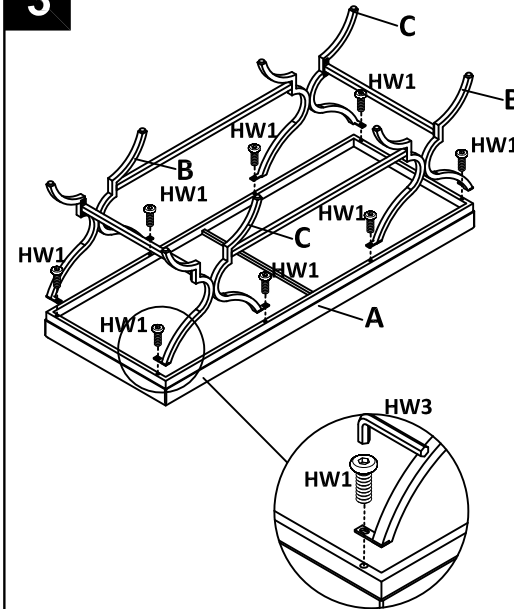

\*Do not fully tighten the bolts until the product is assembled.

### Step 3:

Attach the assembled metal base to the underneath of Seat Cushion (A), Align all screw holes on seat cushion (A) with the holes on the metal base, Use the Allen Key (HW3) to screw in the Hex Socket Bolts (HW1) through the holes on the Side Frame and into the Seat Cushion Frames. See image above.

4

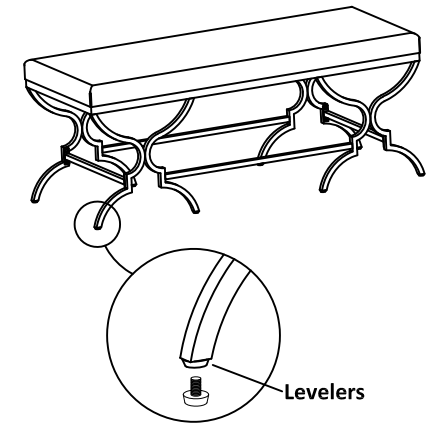

\*After properly adjusting the levelers for stability, then fully tighten all bolts.

### Step 4:

Turn the assembled product upright. Use the levelers to adjust the product if needed. Assembly is now complete.