

CARE AND MAINTENANCE

Always use felt pads under all articles to prevent discoloration or softening of the lacquer. Plastic and rubber bases on items can discolor wood. Wipe up spills immediately and avoid common hazards such as hot dishes, harsh solvents and abrasives. Cleaning should be done with a soft lint free cotton cloth dampened with water.

SAFAVIEH FURNITURE

MODEL# AMH8504





PRODUCT DIMENSION: 36"W X36"L X 36"H

NOTICE

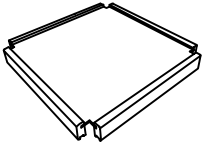
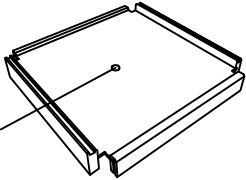
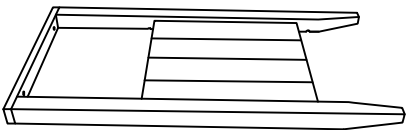
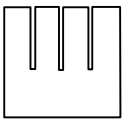
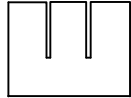
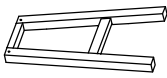
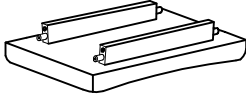
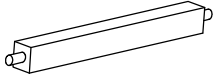
- *Please make sure that you have all parts indicated before you begin assembly of this item
- *This item should be assembled on a soft surface to prevent scratching the finish during assembly
- *This item may require periodic tightening

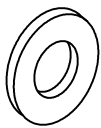
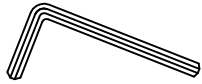

Parts Identification :		PCS
A	Table Top 	1
B	Top Panel 	1
C	Bottom Panel 	1
D	Table Leg Frame 	2
E	Vertical Panel 	2
F	Horizontal Panel 	3
G	Chair Leg Frame 	4
H	ChairSeat 	2
I	Stretcher 	4

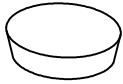
Hardware Identification :			PCS
1	Short Bolt 		4
2	Long Bolt 		8
3	Lock Washer 		12
4	Flat Washer 		12
5	Allen Wrench 		2
6	Wood Screw 		16
7	Wood Plug 		16

PREPARATION

Before beginning assembly of product, make sure all parts are present. Compare parts with package contents list and hardware contents list.
 If any part is missing or damaged, do not attempt to assemble the product.
 Estimated Assembly Time:30 minutes.
 Tools Required for Assembly (included): N/A

Step 1

Align and insert the vertical panel into the slot on the horizontal panel

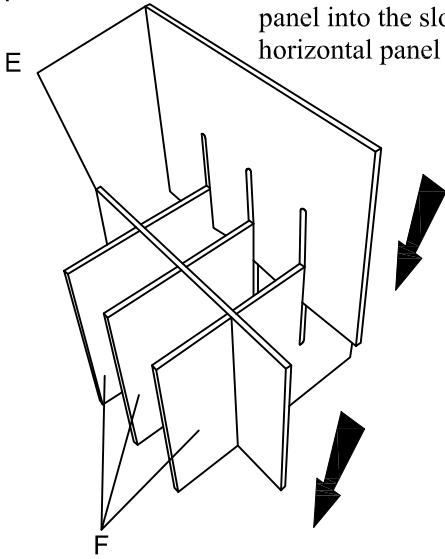

Step 2

Align and fasten top panel to leg frame using long bolt, lock washer, and flat washer, then tighten with Allen wrench (DO NOT TIGHTEN YET)

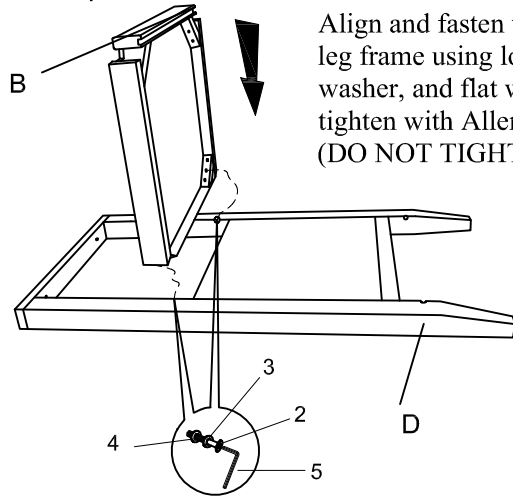

Step 3

Place the assembled wine rack onto the leg frame from step 2

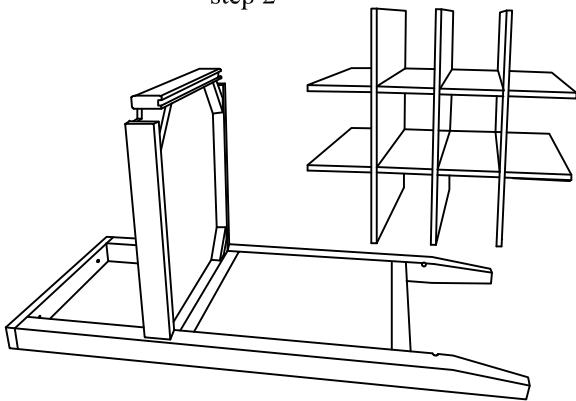

Step 4

Align and fasten the other leg frame to top panel using long bolt, lock washer, and flat washer and tighten with Allen wrench (DO NOT TIGHTEN YET)

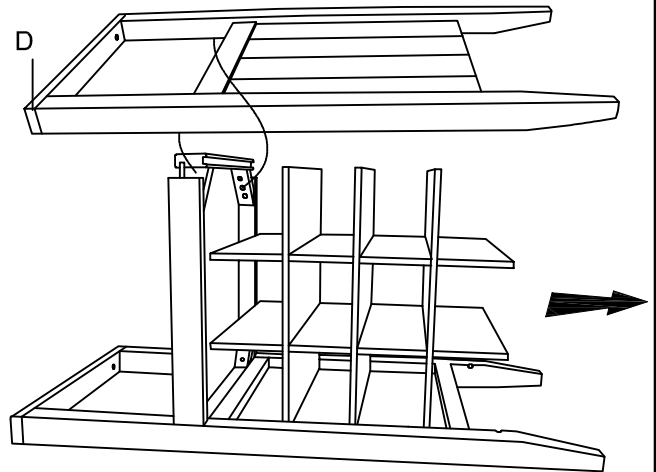

Remark: Push the wine rack towards the bottom of leg frame when assemble the other leg frame with top panel.

Step 5

Place the partially assembled table base upside down on soft surface Align and fasten bottom panel to leg frames using long bolt, lock washer, and flat washer and tighten with Allen Wrench (DO NOT TIGHTEN)

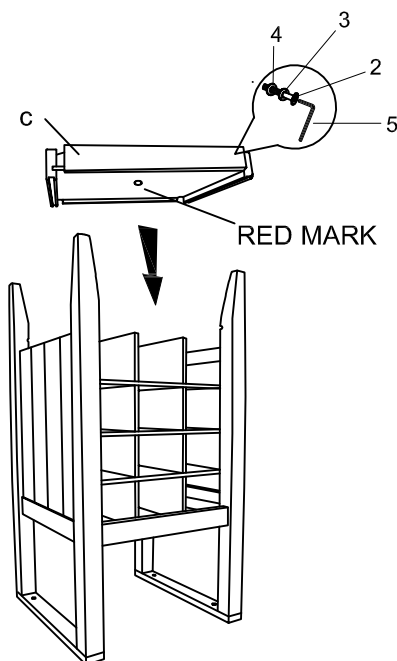

Step 6

Place the table on the floor. Align and fasten table top to table base using short bolt, lock washer, and flat washer and tighten with Allen wrench

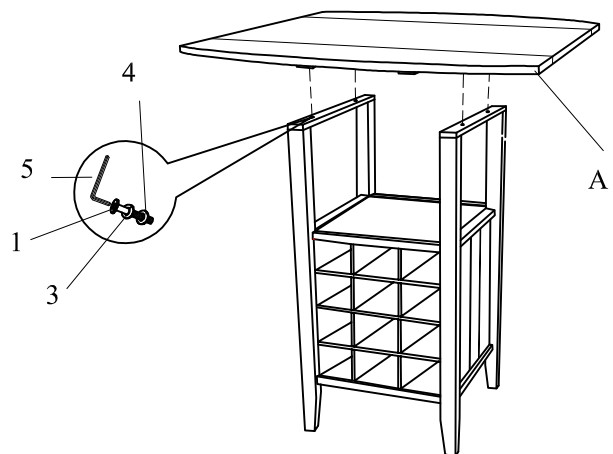

Step 7

Tight all the screw from Step 2 to Step 5

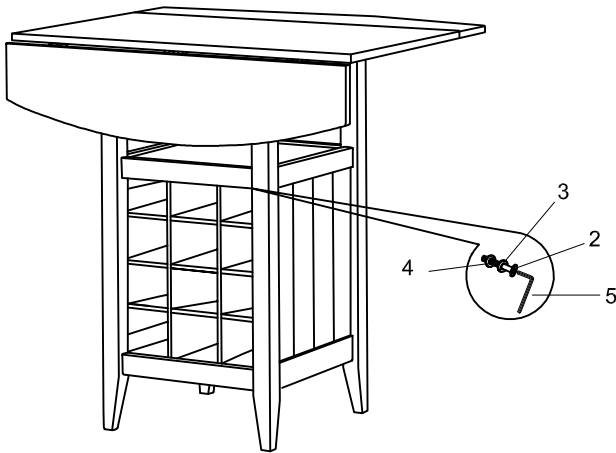

Step 8

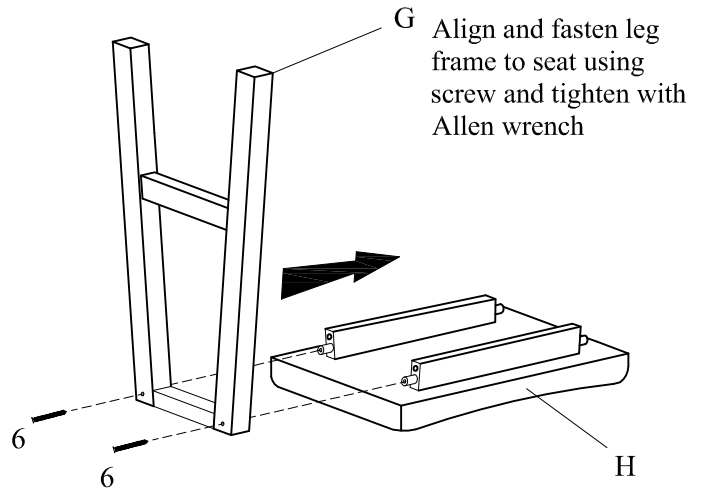

Step 9

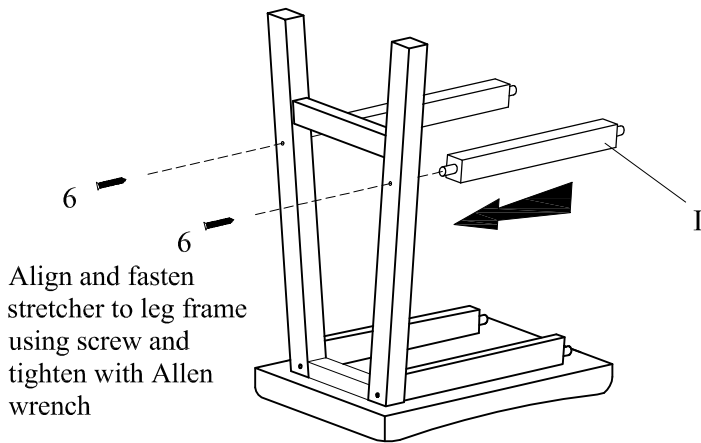

Step10

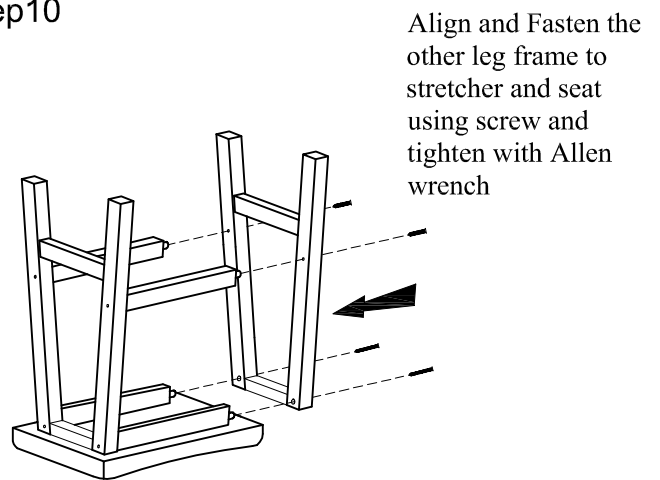

Step 11

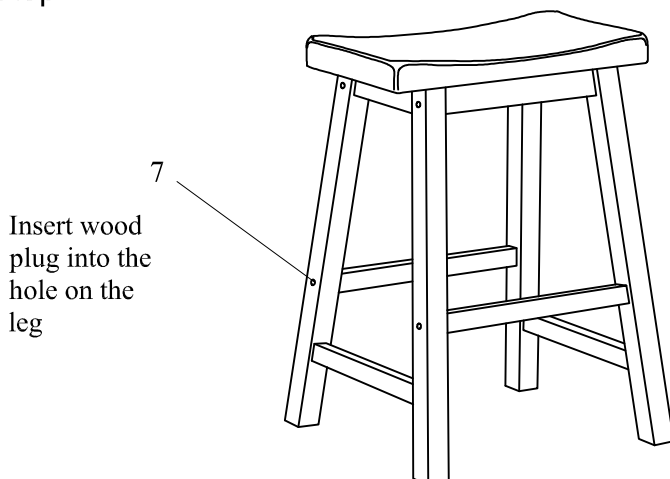

Complete

