

CARE AND MAINTENANCE

Always use felt pads under all articles to prevent discoloration or softening of the lacquer. Plastic and rubber bases on items can discolor wood. Wipe up spills immediately and avoid common hazards such as hot dishes, harsh solvents and abrasives. Cleaning should be done with a soft lint free cotton cloth dampened with water.



MODEL# AMH8503A







PRODUCT DIMENSION: 24"W X 44"L X 36" H

NOTICE

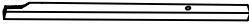
*Please make sure that you have all parts indicated before you begin assembly of this item

*This item should be assembled on a soft surface to prevent scratching the finish during assembly

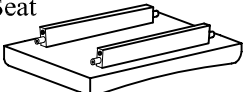
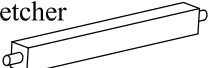
*This item may require periodic tightening

NO.	TABLE PARTS	QTY
1	Table Top 	1
2	Table Legs (2 Left & 2 Right) 	4
3	Table short crossbar 	2
4	Table Long Crossbar 	1
5	Leg Frame 	6
6	Stool Seat 	2
7	Stool Stretcher 	4
8	Bench Seat 	1
9	Bench Stretcher 	2

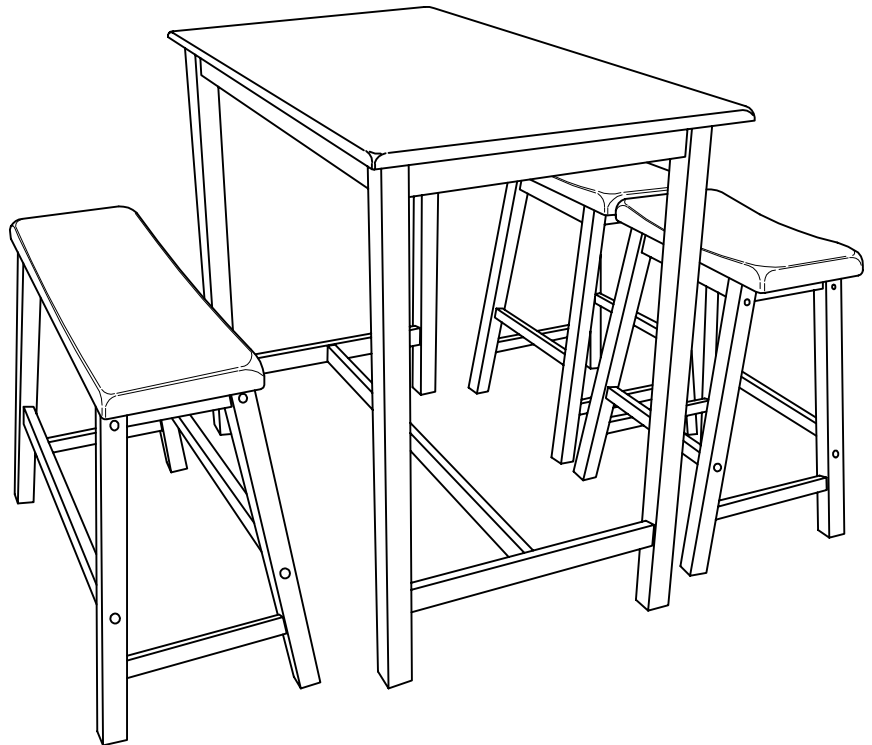





PREPARATION

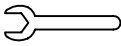

Before beginning assembly of product, make sure all parts are present. Compare parts with package contents list and hardware contents list.

If any part is missing or damaged, do not attempt to assemble the product.

Estimated Assembly Time: 10 minutes.

Tools Required for Assembly (included): N/A

NO.	HARDWARE PACKAGE	QTY
A	SPANNER 	1
B	HEX NUT 	8
C	LOCK WASHER $\frac{5}{16}$ 	8
D	FLAT WASHER $\frac{5}{16}$ 	8
E	WOOD SCREW M4 X 38 	6

NO.	HARDWARE PACKAGE	QTY
F	Wood Screw 	24
G	Allen Wrench 	1
H	Wood Plug 	24

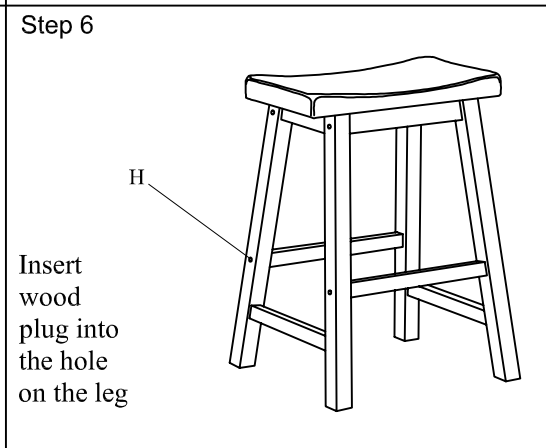
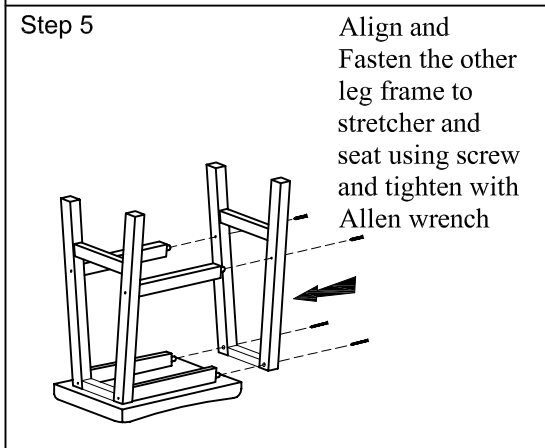
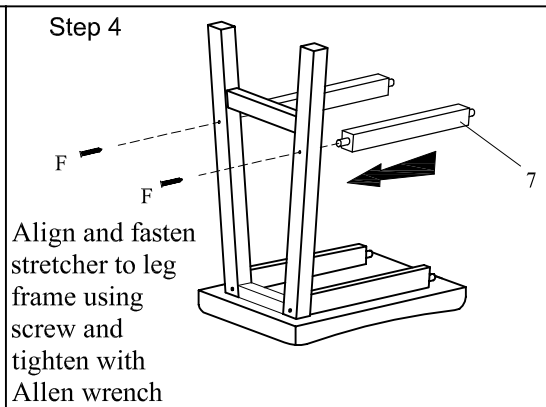
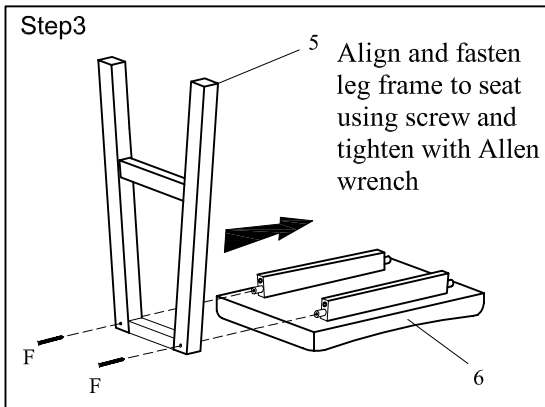
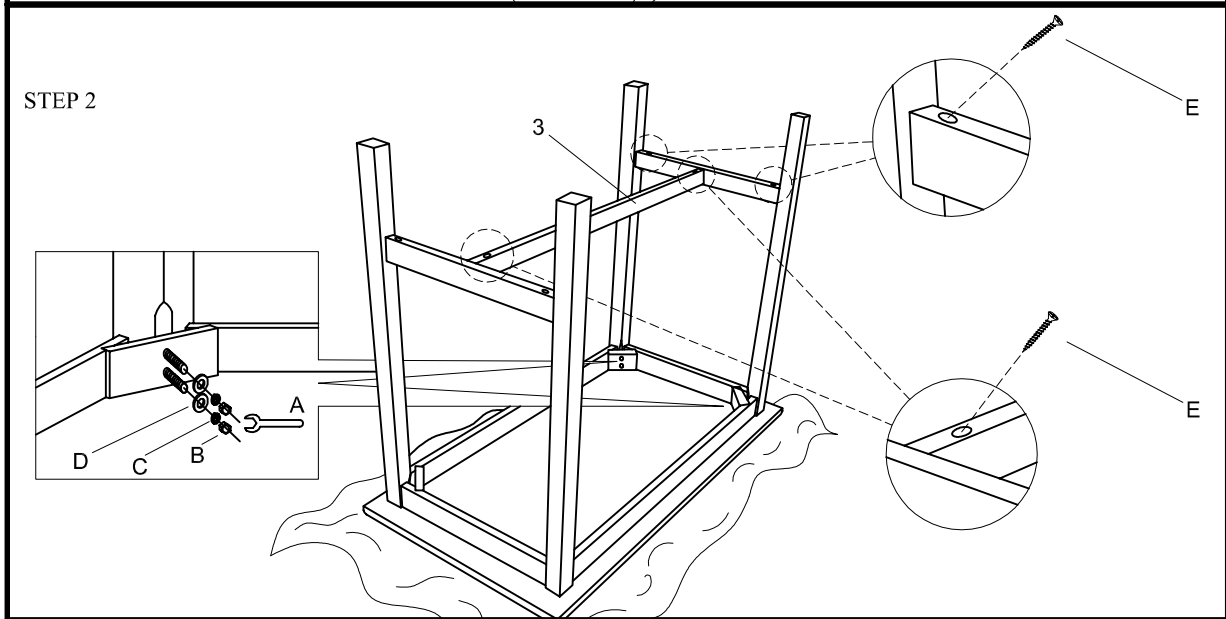
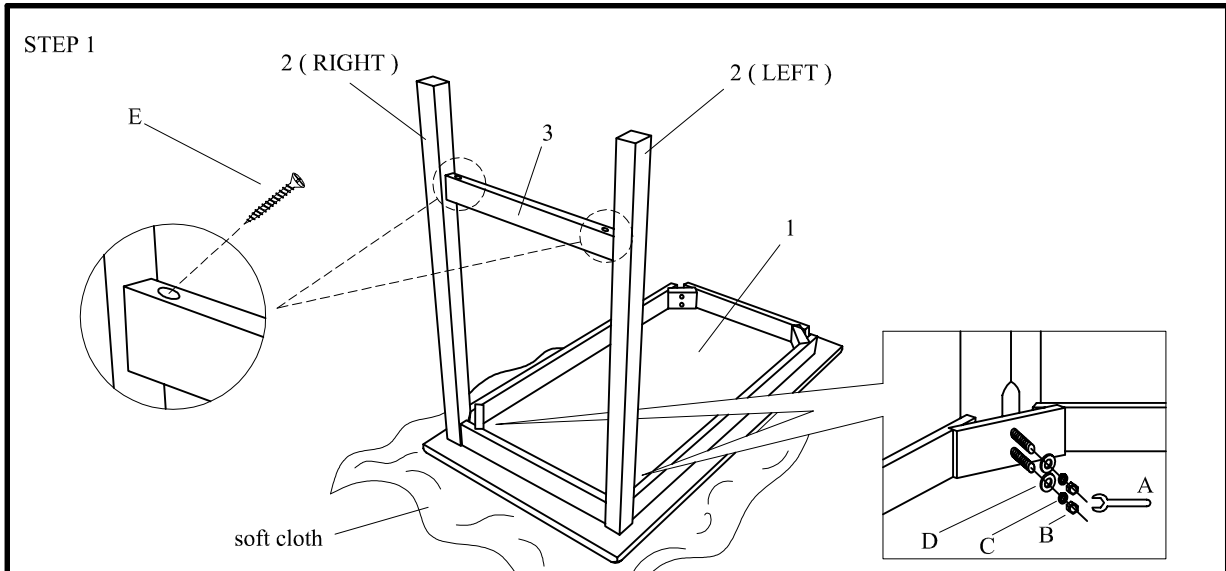

STEP 7

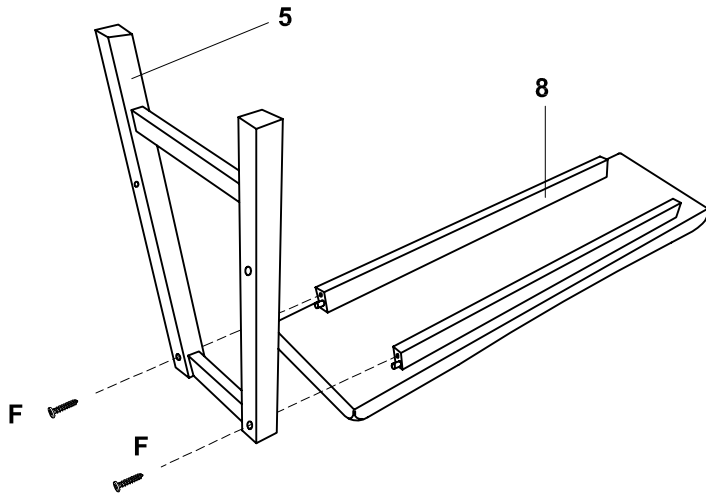

Place seat upside down smooth carpenter surface. Line up legs of Leg Frame (5) with screw holes on bottom of Bench Top (8) and attach with using JCBC screw (F).

STEP 8

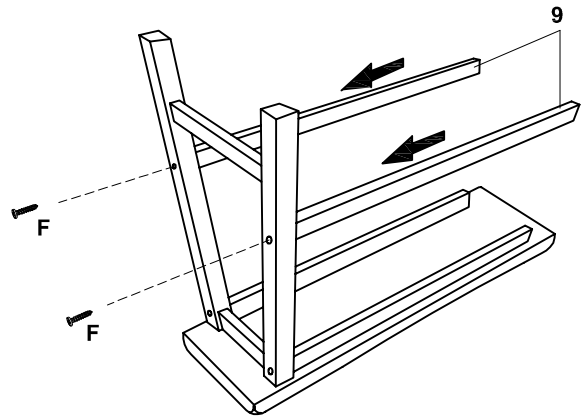

Insert cross bar (9) into leg frame (5) and secure with JCBC screw (F).

STEP 9

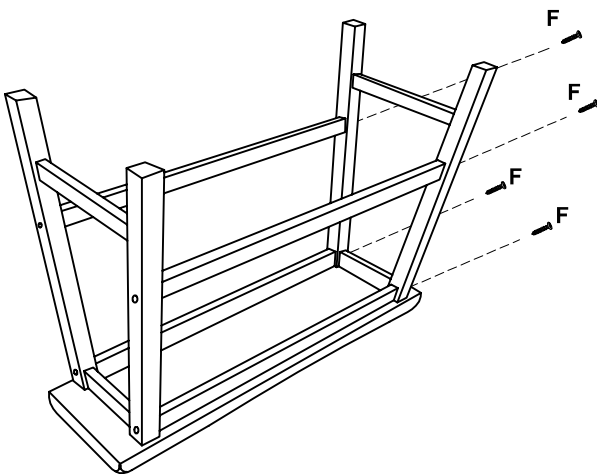

Line up of second leg Frame (5) with screw holes on bottom of Bench Top (8) and attach using JCBC screw (F). Do not tighten these screw all the way until you insert the cross bar (9) when all holes are aligned. Tighten all remaining screw.

STEP 10

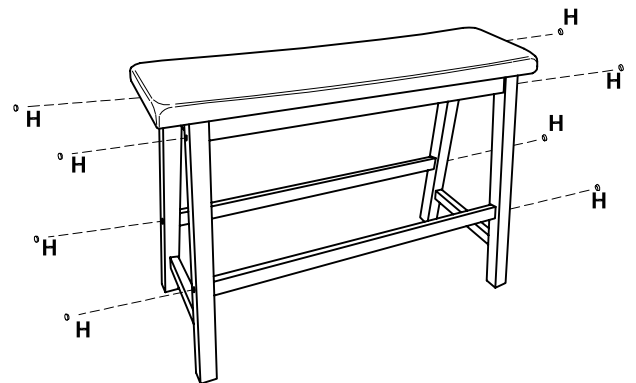

Do not tighten screw until fully assembled and level. Insert wood bottom (H) into every screw hole in leg.